

IF IN DOUBT ASK  
DO NOT SCALE

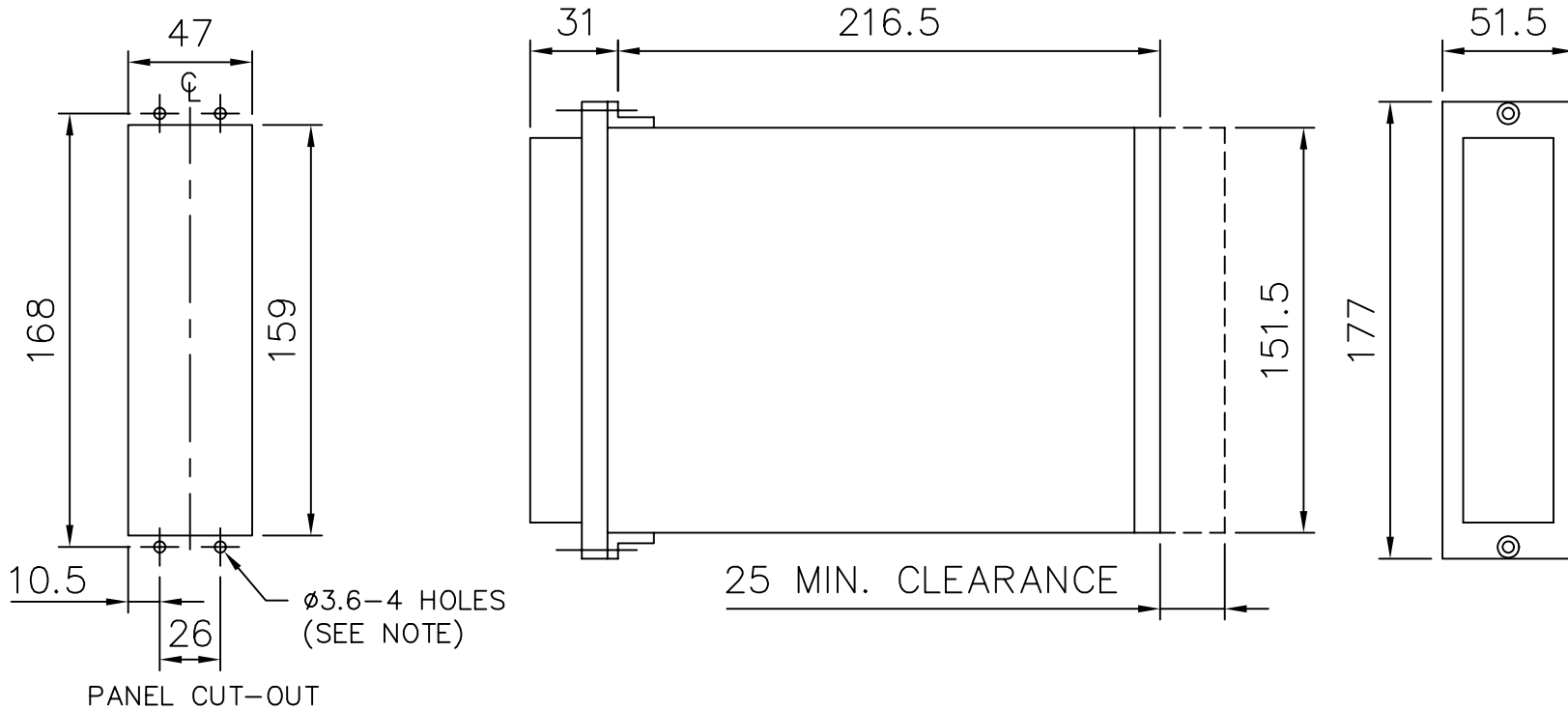

DRAWING OFFICE ONLY NOTE

ANY CHANGE TO THIS DRG MUST BE REFLECTED ON DRG 2995X10017 & CATALOGUE

NOT SUBJECT TO UPDATE  
 ONCE COPIED / PRINTED  
 OR DOWNLOADED

NOTE:

THE  $\phi 3.6$  HOLES ARE FOR M4 THREAD FORMING (TRILOBULAR) SCREWS. THESE ARE SUPPLIED AS STANDARD AND ARE SUITABLE FOR USE IN FERROUS/ALUMINIUM PANELS 1.6mm THICK AND ABOVE. FOR OTHER PANELS, HOLES TO BE M4 CLEARANCE (TYPICALLY  $\phi 4.5$ ) AND RELAYS MOUNTED USING M4 MACHINE SCREWS, NUTS AND LOCKWASHERS (SUPPLIED IN PANEL FIXING KIT).

Copyright © 1999 Reyrolle Ltd.

2	30/7/01	MN995/2125
1	09/07/99	CHANGE
ISSUE	DATE	NOTED

MATERIAL:

Dimensions in millimetres : Surface texture in micrometres. Machine where marked <input checked="" type="checkbox"/> For explanation of dimensions, tolerances, notes etc. see B.S.308. Limit on untoleranced unmachined dimensions $\pm$ _____ Limits on untoleranced machined dimensions to B.S.4500; i.e. up to $6\pm 0.1$ ; over 30 to $120\pm 0.3$ ; over $315\pm 0.8$ ; over 6 to $30\pm 0.2$ ; over 120 to $315\pm 0.5$ ; General unmachined angular tolerance $\pm$ _____	Finish:	Title. <b>OVERALL DIMENSIONS AND PANEL DRILLING FOR EPSILON E2 CASE.</b>	First used on:
	Treatment:		<b>Reyrolle Protection Hebburn.</b>
Original Scale. <b>NTS</b>		Drg.No. <b>2995X10002</b>	
DRAWN: T.CARR	CHECKED:	APPROVED: R.D.WATSON	DATE: 11/07/02
I.E.	OPS.	PCP.	Purch. Spec.
TQ.	EAC	CE.	STD.
A4h			