

## **VA TECH TRANSMISSION & DISTRIBUTION**

### **VA TECH Reyrolle ACP Ltd**

## **Solkor - operating recommendations**

### **INTRODUCTION**

This manual details operating recommendations for Solkor R and Solkor Rf current differential pilot wire feeder protection. It also covers optional pilot supervision schemes and intertripping schemes (see appendix A and B).

### **COMMISSIONING**

#### **Test equipment required**

The following equipment is required:-

- A 500V insulation-resistance test-set.
- A heavy-current transformer capable of injecting a minimum of 10 to 15% of C.T. rated primary current through the feeder.
- A secondary injection test set ( 0 -10A ).
- An ammeter and a metering current-transformer for measuring primary currents.
- Three multi-purpose indicating instruments.
- An ohmmeter.
- 200 watt 2000 ohm resistor ( DC to AC inverter test ).

#### **Test programme**

Apply the tests in the order below:-

- Check of connections.
- Secondary-wiring insulation-resistance tests.
- Current-transformer ratio and polarity tests.
- Pilot tests.
- Overall fault-setting tests.
- Circuit-breaker tripping tests.
- Stability tests.

#### **Precautions**

Do not open-circuit the secondary winding of a current-transformer while there is a current in its primary winding otherwise a high voltage will be produced in the secondary which may be dangerous to personnel and may also damage the secondary wiring insulation.

### **Check of connections**

Check that all connections between the various pieces of equipment are in accordance with the appropriate schematic diagram and that all connections are tight.

Fig. 6 shows the only permissible connection arrangements.

### **Connection**

Where isolating transformers are used the terminals connected to the pilots should be carefully checked to ensure that the same tap is used at each end.

The protection should normally be connected on the N tapping. The N1 tapping should only be used where very low settings are required (e.g. in non-effectively earthed systems), and because of its greater sensitivity, care is necessary in the choice of current-transformers. It should be noted that the N1 tapping is not brought out to a terminal on the relay backplate, and if it is to be used the lead which is normally connected to the terminal N on top of the summation transformer should be connected to the adjacent N1 terminal.

Examine the relay giving special attention to the following points:

- Wipe off any dust from the outside of the relay and remove the cover.
- See that the armature and contacts move freely and that the flag indicates when the relay is operated by hand.
- Record particulars of any damage, repairs or adjustments found necessary.

### **Secondary wiring insulation-resistance test**

This test should not include the pilots, which should be tested separately as described in "Pilot Tests".

With all earth-connections, earth-links, and supply fuses and links removed, measure the resistance to earth of all

the secondary wiring. Satisfactory values for the various readings depend upon the amount of wiring concerned. Where considerable multi-core wiring is involved, a reading of 2.5 to 3 megohms is satisfactory. For short lengths of wiring the readings should be higher. A value of 1 megohm should not normally be considered satisfactory.

### Current-transformer ratio and polarity tests

If testing by single-phase primary injection is not possible, make the alternative tests detailed on page 7.

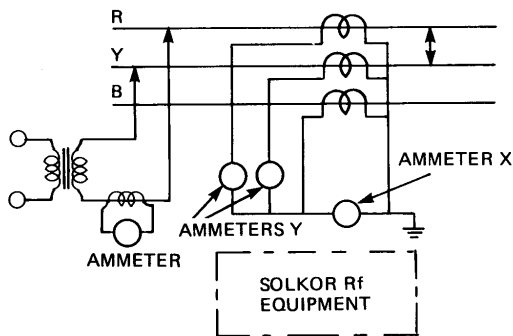

Fig. 1(a) Phase to phase injection

Remove the trip-links. Connect the test-circuit as shown in Fig. 1(a) and inject a primary current of 50 per cent or more of the current-transformer-primary rating in order to obtain a reliable secondary-current reading. Check that the ratio of current-transformer is correct by referring to the readings on ammeters Y. Also check that the polarity of the current-transformers, is correct by referring to ammeter X, the readings of which should be negligible compared with those in the individual phases. Repeat the tests for at least one other phase-to-phase fault condition.

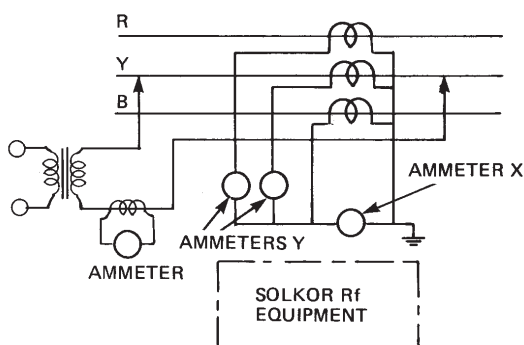

Fig. 1(b) Single phase injection

Connect the test supply to simulate a yellow earth fault as shown in Fig. 1b. Inject a suitable value of primary current and check the readings on ammeters X and Y. The reading of ammeter X should equal the reading of the ammeter Y which is connected in the yellow phase C.T. secondary.

Repeat the tests at the other end of the feeder.

Tabulate the results as shown in Table 1.

Test condition	Primary current (amps)	Secondary current (A)			
		Red phase	Yellow phase	Blue phase	Neutral
Feeder end 1	R-Y				
	Y-B				
	Y only				
Feeder end 2	R-Y				
	Y-B				
	Y only				

Table 1 C.T. ratio and polarity tests

### Pilot tests

#### Insulation-resistance test

The voltage for the insulation-resistance test of the pilots should not exceed the nominal insulation level of the pilots, and the test should be made as follows:

With the pilots disconnected from the relay at both ends of the feeder, apply the insulation resistance test between the pilot cores, and between each core and earth. This test should be carried out with an insulation resistance test set. Compare the readings obtained with the value quoted by the manufacturer of the pilot-cable.

#### Pilot-loop resistance tests

With the pilots disconnected at both ends of the feeder, join the cores together at one end and measure the pilot-loop resistance from the other end. If the pilot loop resistance is less than the standard value for the particular arrangement being used (See Table 2) add padding resistance at each end. If isolating transformers are being used, choose the secondary tap to suit the measured pilot resistance. Thus for a pilot loop resistance lower than 440 ohms choose tap T1; for a pilot loop resistance between 440 ohms and 880 ohms choose tap T2; For a pilot loop resistance between 880 ohms and 1760 ohms choose tap F2. This will ensure that pilot capacitance will have a minimal effect upon the relay fault setting. The padding resistor comprises five series-connected sections, each section having a short-circuiting link. The values of resistance in the sections are 35 ohms, 65 ohms, 130 ohms, 260 ohms and 500 ohms. One or more sections can be inserted by removing the appropriate link or links which are located on the link-board. Choose the same value at each end.

It should be as near as possible to:

$$\frac{(SV-RP)}{2T}$$

$$2T$$

where SV = Standard Value from Table 2

RP = Pilot Loop Resistance

T = Isolating Transformer Tap

= 1.0 if no isolating transformer fitted

= 1.0 for isolating transformer tapping F2

= 0.5 for isolating transformer tapping T2

= 0.25 for isolating transformer tapping T1

Table 2 shows the standard pilot loop resistance and maximum inter-core capacitance permissible for the various arrangements of Solkor. When isolating transformers are fitted it is recommended that, as a general rule, the tap chosen should be the one which allows the maximum value of pilot capacitance for the measured pilot loop resistance.

When inserting a padding resistance in Vedette case versions, the link should be completely removed on the Vedette case. Do not merely open-circuit the link by pivoting the link on one terminal and leaving it in this position, as this can reduce the insulation level between the padding resistor and earth. For Epsilon and Reymos case

	Transformer former terminal	Transformer former tap value (T)	Standard value of pilot loop resistance (S.V.)	Maximum capacitance between cores F
Solkor R	-	1.0	1000	2.5
Solkor Rf without isolating transformers	-	1.0	2000	0.8
Solkor Rf with isolating transformers	F2	1.0	1760	1
	T2	0.5	880	2
	T1	0.25	440	4

**Table 2 Resistance and capacitance limitations**

versions, the resistors are inserted by changing the plug position.

**Pilot connection check**

If isolating transformers are not fitted check that relay terminals 17 at both ends of the feeder are connected by one pilot core and that relay terminals 18 at both ends of the feeder are connected by the other pilot core. For Vedette versions, terminal 5 corresponds to 18 and terminal 12 corresponds to 17.

Do this by disconnecting the pilots at both ends, earthing one core at the remote end and measuring the resistance to earth of each core at the local end. The pilot core giving the lower reading is the one which is earthed at the remote end.

If isolating transformers are fitted check that transformers terminals S2 at both ends of the feeder are connected by

one pilot core. Check that the other pilot core connects transformer terminal F2, T2 or T1 (depending upon which tapping is being used) at one end of the feeder to the equivalent transformer terminal at the other end of the feeder.

**Overall fault-setting tests**

If testing by single-phase primary-injection is not possible, make the alternative tests described on page 4.

The purpose of these tests is to establish the overall fault-settings of the protection and also to establish that the secondary wiring between the current-transformers and the summation transformer at each end is in accordance with the particular diagram supplied for the installation.

Remove the trip-links but ensure that the padding resistors are correctly set. Connect the test-supply initially to simulate a Red-earth fault-condition as shown in Fig. 2 and perform the tests in the following sequence.

Connect a d.c. milli-ammeter in the operating circuit of each relay as shown in Fig. 2.

On Epsilon cased relays, to perform this test, 4mm 'banana' plugs connected to the multipurpose ammeter (selected to DC milliamps) are required. Observe the polarity shown on the relay label. After connecting the meter, remove the test link.

On Reymos relays, test plugs 2109C99022 (Black) and 2109C99023 (Red) are required. Connect the red plug to the positive terminal of the multipurpose ammeter and the black plug to the negative. Remove the relay test link and insert the red plug in the top socket, the black in the bottom socket.

Slowly increase the test current until the local relay operates and record the primary and secondary currents. Check that the relay operating current is approximately 11 to 12 milliamperes and that the current in the relay operating circuit at the remote end is of the same order.

Repeat the test for the other earth fault conditions and also for the phase fault conditions if sufficient test current is available. Tabulate the results as shown in Table 3.

Type of fault	Measured fault setting (amps)				Relay operating current m/amps D.C.		Type of fault	Fault settings									
	Primary current		Secondary current					Solkor Rf without isolating transformers				Solkor Rf with isolating transformers					
	At end 1		At end 2		At end 1			At end 2		Nominal		Typical		Nominal		Typical	
	N1 tap	N tap	N1 tap	N tap	N1 tap	N tap		N1 tap	N tap	N1 tap	N tap	N1 tap	N tap	N1 tap	N tap		
R-E							R-E	16	22	18	25	22	31	25	35		
Y-E							Y-E	18	27.5	21	32	26	39	30	44		
B-E							B-E	22	37	25	42	31	52	35	59		
R-Y							R-Y	110		125		155		177			
Y-B							Y-B	110		125		155		177			
B-R							B-R	55		62		77.5		88.5			
3 PHASE							3 PHASE	63		72		89		101			

**Table 3 Test of fault settings**

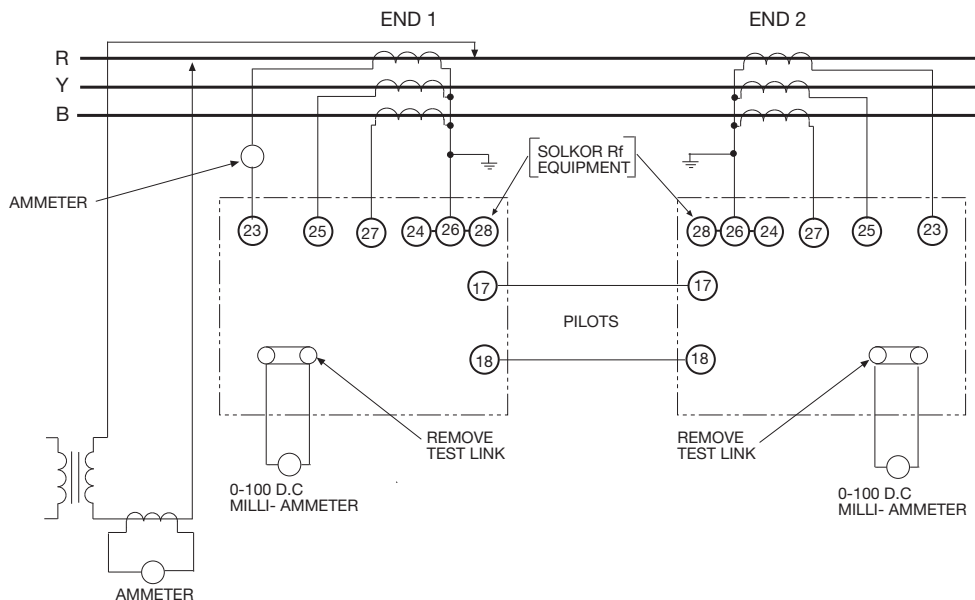

**Fig. 2 Connections for overall fault setting tests by primary injection**

If it is convenient to permit operation of the circuit breaker at this stage, repeat one of the tests with the trip links inserted. Increase the primary current to the setting of the protection; the circuit breaker should then operate thus proving the tripping circuit.

Repeat the tests at the other end of the feeder.

When all the tests have been completed at both ends of the feeder, compare results between ends. Check that the most sensitive earth fault setting at each end refers to the same phase, i.e. the red phase, the next sensitive the Yellow phase and the least sensitive the Blue phase.

It should be noted that primary fault settings vary slightly with the current transformers used and the capacitance of the pilots. With average current transformers the fault settings at zero pilot capacitance are as given in Table 3. Values are expressed as percentages of relay rating.

Fault settings will be practically unchanged for pilot

capacitance values between zero and approximately 80% of the maximum capacitance values specified in Table 2. Values of pilot capacitance higher than this have the effect of increasing the fault settings.

#### Circuit-breaker tripping tests

If it has not been possible to make the tripping-tests described under "Overall fault Setting tests" perform the following test:

Insert the d.c. supply links and fuses, and operate the relay by hand; tripping should occur only when the trip-links are inserted.

#### Stability Tests

The purpose of these tests is to ensure that the pilots are correctly connected and that the current transformers at each end are starred correctly relative to one another in order to permit stabilisation of the protection under through fault conditions.

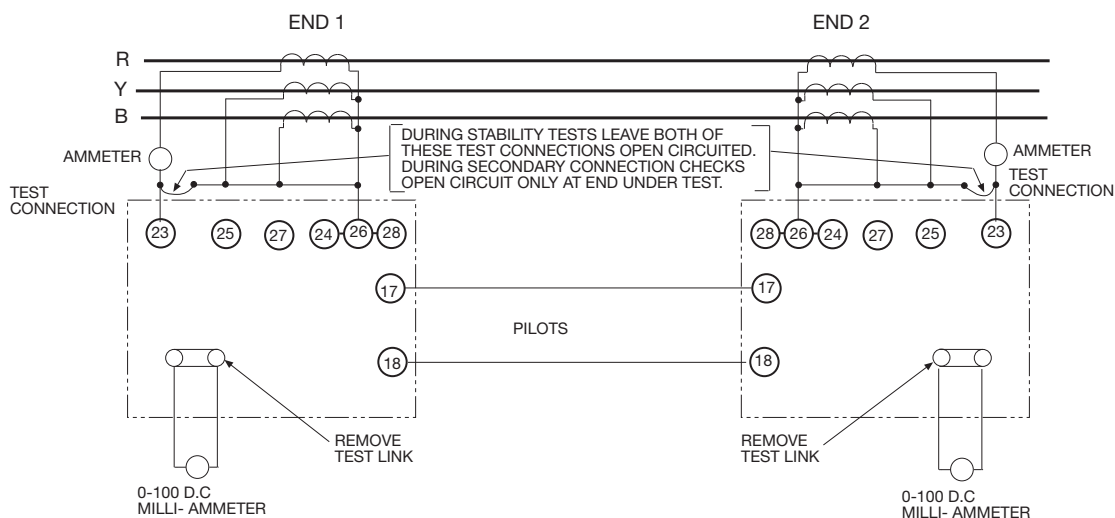

**Fig. 3(a) Connections for stability tests and for check of secondary connections using three phase load current (Solkor-Rf without isolating transformers)**

The test should be made with the load current in the feeder equal to at least 10 -15% of the rating of the feeder current-transformers. Since in these tests all three phases of the primary circuits are energised, take care that the current-transformer secondary leads are not open circuited.

Remove the trip-links at both ends of the feeder but check that the remainder of the equipment, including the pilots, is connected for normal operation.

Connect the secondary circuit at both ends to simulate an external Red-Earth fault condition as shown in Fig. 3(a) (Solkor Rf without isolating transformers) or Fig. 3(b) (Solkor Rf with isolating transformers). Record the various current levels in the test circuit.

If the pilots and current transformers are correctly connected the d.c. current in the operating coils of the relays should be negligible.

Record the results for each end of the feeder as shown in Table 4.

**ALTERNATIVE TESTS IF PRIMARY INJECTION EQUIPMENT IS NOT AVAILABLE**

If it is not possible to do the primary injection tests described under "Overall Fault Setting Tests" and "Current Transformer Ratio and Polarity Tests" then the relay operation should be checked by secondary injection and the C.T. ratio, polarity and the correctness of secondary connections should be checked using three phase load current as described below.

When doing tests using three phase load current take care to ensure that the current transformer secondary leads are never open circuited when current is passing through the primary.

**Check of fault settings by secondary injection**

Remove the trip links and C.T. earth links.

With all the equipment including the pilots connected for normal operation, arrange the test circuit as shown in Fig. 4. Slowly increase the test current until the local relay operates and record the value of test current. Check that the relay operating current is approximately 11 milli-amperes and that the current in the relay operating circuit at the remote end is of the same order.

Repeat the tests for the other earth fault conditions and also for the phase fault conditions. Tabulate the results as shown in Table 3.

If it is convenient to permit operation of the circuit breaker at this stage, repeat one of the tests with the trip links inserted. Increase the test current to the setting of the protection; the circuit breaker should then operate thus proving the tripping circuit.

Repeat the tests at the other end of the feeder.

Conditions of current transformers connections			Primary current (A)	Secondary current (A)	Tripping relay current (mA d.c.)
Feeder ends 1	R-E	Normal			
		Reverse			
	Y-E	Normal			
		Reverse			
	B-E	Normal			
		Reverse			
Feeder ends 2	R-E	Normal			
		Reverse			
	Y-E	Normal			
		Reverse			
	B-E	Normal			
		Reverse			

**Table 4 Stability tests**

Reverse the leads to terminals 10 (23) and 7 (28) at one end of the feeder to simulate an internal Re-Earth fault. Alternatively reverse the pilot connections at one end of the feeder to unbalance the protection.

Check that there is a large increase of d.c. current in the operating coils of the relays.

If required repeat these tests for the other phase to earth conditions.

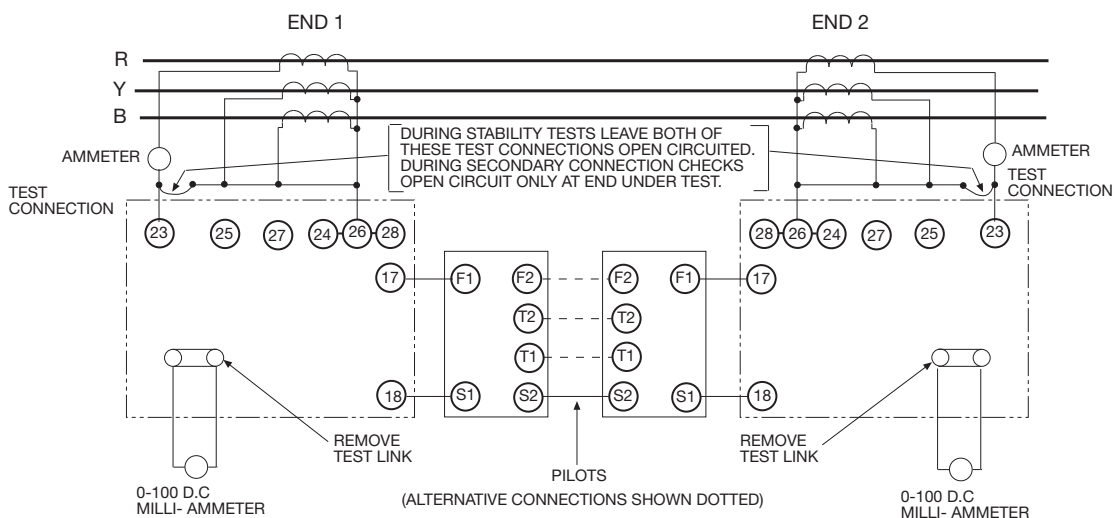

**Fig. 3(b) Connections for stability tests and for check of secondary connections using three phase load current (Solkor-Rf with isolating transformers)**

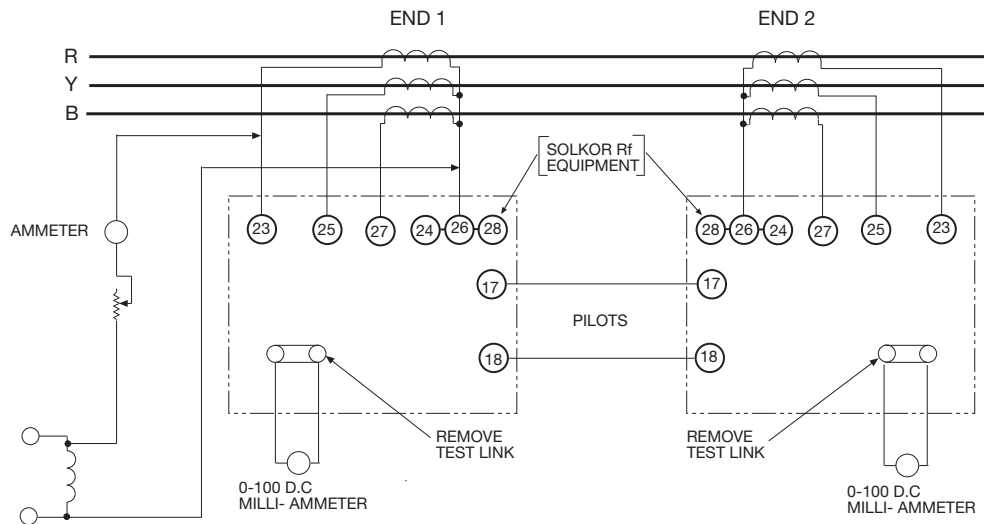

**Fig. 4 Connections for overall fault setting tests by secondary injection**

**Current transformer ratio and polarity tests**

Remove the trip links at both ends of the feeder. Connect ammeters in the current transformer secondary leads at each end in turn, as shown in Fig. 5. Pass three phase load current through the primary and check the ratio of each current transformer by comparing the secondary current in each phase with the corresponding primary current. Check the polarity of the current transformers; the reading of ammeter X in the neutral circuit should be negligible compared with the secondary phase-currents. Some current may exist in the neutral circuit due to unbalance of primary load current and/or secondary burden.

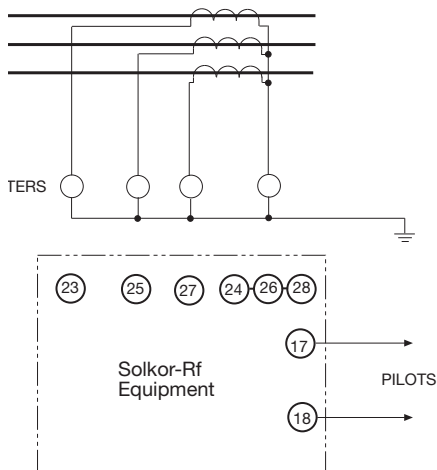

**Fig. 5 Connections for current transformer ratio and polarity tests using three-phase load-current**

**Check of secondary connections**

The purpose of these tests is to establish that the secondary wiring between the current-transformers and the summation-transformer at each end is in accordance with the particular diagram supplied for the installation. However, if load-current is to be used it is unlikely that actual setting-values can be obtained in which event it is considered reasonable if suitable readings can be taken to confirm that the feeder ends behave similarly for the same

fault-condition. Care should be taken that there is a reasonable value of load current available i.e. 25% to 50% of nominal.

Remove the trip-links. Check that the pilots are connected at each of the feeder and that the padding resistors are correctly set. In order to obtain comparable readings at each end the primary-current should remain constant. When using load-current this condition can best be approached by taking readings for a given fault-condition at each end in turn. With this object in view, initially connect the secondary circuit at each end as shown in Fig. 3a (Solkor Rf without isolating transformers) or Fig. 3b (Solkor Rf with isolating transformers). For a Red-Earth fault-condition remove the short-circuiting connection from the Red-phase current-transformer at the end of which the first readings are to be obtained. Measure the current in the operating-coil of the relay at this end, also the primary and secondary currents, and record the readings. Replace the short-circuiting connection across the Red-phase current-transformer, and repeat the above procedure at the other end to obtain comparable readings for the Red-Earth fault-conditions.

In a similar manner, by suitably connecting the current-transformer secondary leads at each end, obtain alternate readings at each end for the Yellow-Earth and Blue-Earth fault-conditions. Tabulate the results as shown in table 5 and compare results between ends.

Type of fault	Primary current (A)	Secondary current (A)	Tripping relay current (mA d.c.)	
			Feeder end 1	Feeder end 2
R-E				
Y-E				
B-E				

**Table 5 Check of secondary connections using 3 phase**

**Putting into service**

To put the equipment into service, perform the following sequence of operations at each end of the feeder.

Insert the supply links and fuses

Make a final inspection to ensure that the equipment is ready for automatic tripping. In particular check that the flag-indicator is re-set, that the metering test-link of each relay is firmly inserted and that all connections are tight.

Finally, insert the tripping links, the protection is then ready for service.

## OPERATION

No action is required in the event of a fault on the primary circuit external to the protective zone.

On clearance of an internal fault the relay should automatically reset, but the flag-indicator would require to be reset by hand. It should only be reset after the fault has been logged.

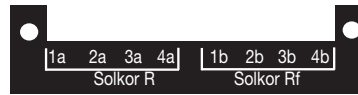

### For Solkor R Mode:

Wires numbered 1, 2, 3 and 4 have to be connected to terminals 1a, 2a, 3a and 4a respectively.

### For Solkor-Rf Mode:

Wires numbered 1, 2, 3 and 4 have to be connected to terminals 1b, 2b, 3b and 4b respectively.

Type of case	Diagram	R	Y	B	N	P0	P1	Contact 1	Contact 2	Contact 3
E6 Epsilon	2651W50006	23	25	27	24	17	18	1 3	2 4	6 8
1p Vedette (2M)	2651W10020	10	9	8	7	12	5	1 2	3 4	-
1p Vedette (3M)	2651W10110	10	9	8	7	12	5	1 2	3 4	15 16
R6 Reymos (2M)	2651W10127	23	27	25	24	17	18	1 3	2 4	-
R6 Reymos (3M)	2651W10123	23	27	25	24	17	18	1 3	2 4	6 8
R6 Reymos from 3/90	2651W10141	23	25	27	24	17	18	1 3	2 4	6 8
R4 CEE	2651W10120	2	6	10	15	19	21	16 13	9 8	-

**Table 6 Terminal numbers of various types of Solkor-Rf relays**

## MAINTENANCE

The maintenance test required will largely depend upon experience and site conditions; but it is recommended that the inspection and tests under "Check of Connections", "Secondary Wiring and Insulation Resistance Tests", "Pilot Tests" and "Overall Fault-Setting Tests", be performed every twelve months.

### SOLKOR RF RELAY - CONNECTIONS FOR USE IN SOLKOR R MODE

Solkor-Rf relays can be connected for operation in the Solkor-R mode. This can be used with Solkor-Rf relays at both feeder ends, or with a Solkor-Rf relay at one end and a Solkor-R at the other. This latter instance will often occur when extensions are made to existing installations. Tests described in the Operating Recommendations for Solkor-R relays are appropriate to Solkor-Rf relays connected in the Solkor-R mode.

Before commissioning a Solkor-R relay it must be checked to determine that it is correctly connected for the chosen mode of operation. This is done by withdrawing the relay element from the case and inspecting four connections to a terminal block, as shown in the following illustrations.

## NOTES

- 1) To operate a Solkor-Rf relay in the Solkor-R mode it is also necessary to change the internal terminal block connections and also link external relay terminals 18 and 20 (Epsilon and Reymos) or 20 and 21 (C.E.E.) or 5 and 11 (Vedette) cases.
- 2) When operating in the Solkor-R mode the maximum pilot loop resistance is 1,000 Ohms.
- 3) From March 1990 Reymos modular cases had the current transformer connections R-Y-B to terminals 23, 25 and 27 respectively.

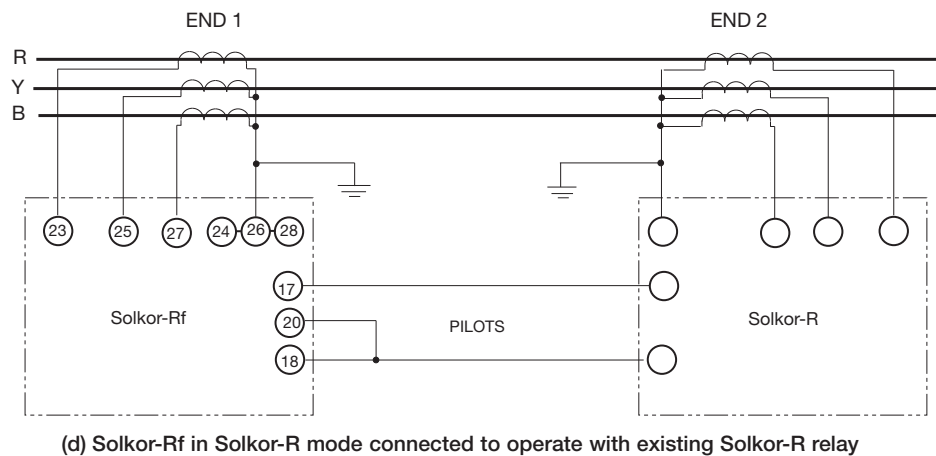
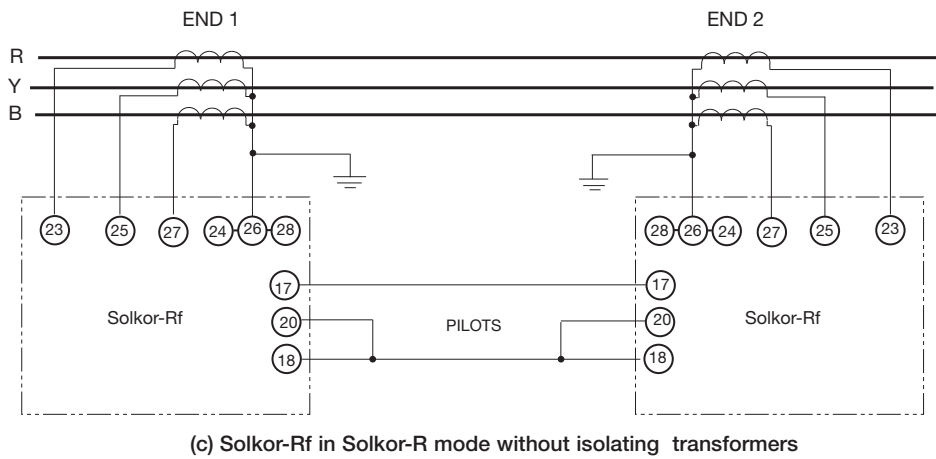
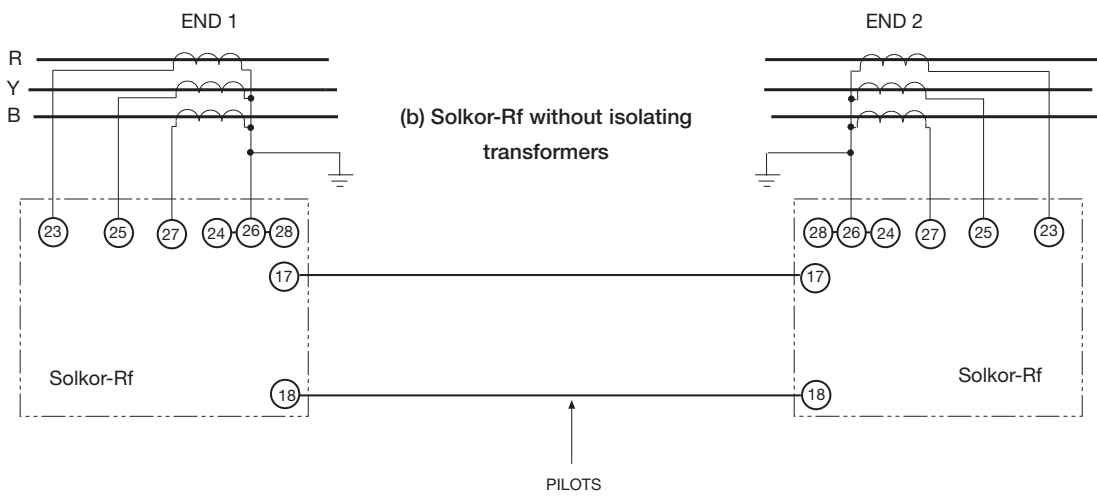
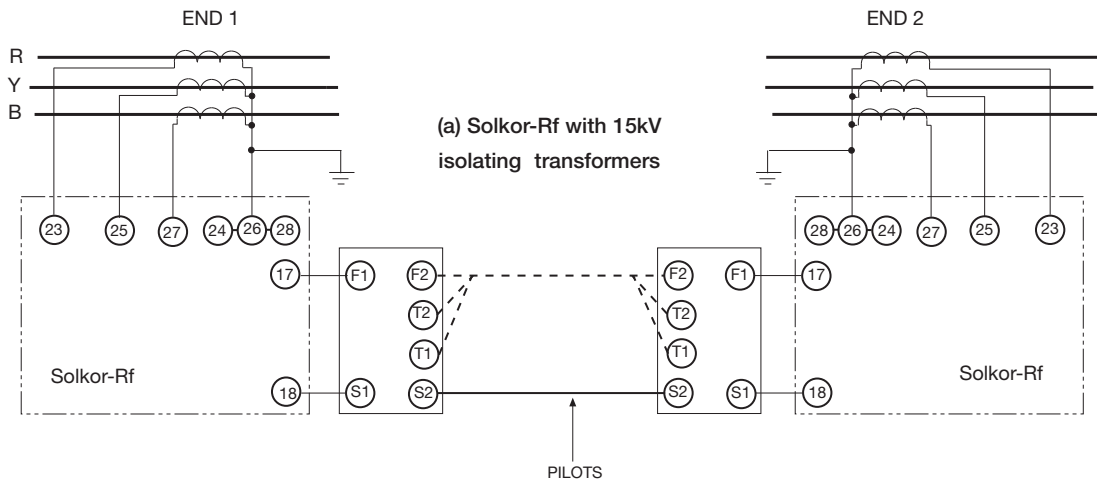

Fig. 6 Connection diagrams (Epsilon case terminal numbers)

## APPENDIX

### PILOT SUPERVISION EQUIPMENT

#### INTRODUCTION

Prior to 1988 pilot supervision was only available in the Vedette drawout case and this equipment was manufactured suitable for 15kV Insulated pilot circuits. Thus it can be applied to both 5kV and 15kV schemes. Since 1968 it is now possible to purchase pilot supervision in Epsilon modular cases, however these cases are restricted for use on 5kV insulated pilot circuits.

#### DESCRIPTION OF EQUIPMENT

The supervision equipment comprises:-

- a) At the supervision supply end:-
  - One transformer - rectifier supervision supply unit
  - One supervision supply failure relay (if required)
- b) At the supervision receive end:-
  - One pilot supervision receive relay
  - One pilot supervision receive repeat relay

For the 5kV scheme in the Epsilon modular case system, both elements are combined into one size E4 case.
- c) On some installations guard relays are fitted to prevent tripping of the circuit breaker should the Solkor protection operate under load conditions due to the pilots becoming open circuited.

The operating coils of the guard relays are connected in series with the summation transformer at each end of the feeder and the contacts of the guard relays are in series with the Solkor tripping contacts.

The setting of the phase fault guard relays should be lower than one half of the minimum phase fault current available and higher than the maximum available load current.

The setting of the earth fault guard relay which is connected in the neutral lead of the C.T's should be lower than one half of the minimum earth fault current available.

A typical Solkor Rf installation using pilot wire supervision and guard relays is shown in Fig. 8

#### COMMISSIONING TESTS

Preferably do the tests in the order given below:-

- Check of Connections
- Secondary Wiring Insulation Tests
- Pilot Tests
- C.T. Ratio and Polarity Tests
- Overall Fault Setting Tests
- Tests of Pilot Supervision Relays
- Overall Tests of Pilot Supervision Equipment
- Stability Tests

#### Check of connections

Make a general check of connections as described in the appropriate Operating Recommendations

#### Secondary wiring insulation resistance tests

Check the insulation resistance of the secondary wiring as described in the appropriate Operating Recommendations.

#### Pilot tests

Before doing these tests, ensure that the pilot supervision relay and the transformer-rectifier supervision supply until are disconnected from the pilots.

Follow the procedure described in the appropriate Operating Recommendations to check the pilot Insulation resistance, the pilot loop resistance, the correctness of the pilot connections and to select a suitable value of padding resistor.

#### C.T. ratio and polarity

Check the current transformers for ratio and polarity as described in the appropriate Operating Recommendations.

#### Overall fault setting tests

Fitting pilot supervision to Solkor R or Rf protection affects the overall fault setting. The change in setting is influenced by several factors, eg. whether the relay is connected in the Solkor R or Solkor Rf mode, whether isolating transformers are fitted, the value of pilot capacitance current and in some cases the end from which the fault is fed.

As a general guide for Solkor Rf protection, one could expect the fault setting to increase by between 20 to 50%.

For Solkor R protection (or Solkor Rf protection connected in the Solkor R mode) a similar increase in setting can be expected at the local end but the remote end setting decreases and both local and remote ends will trip at approximately the same value.

Due to this variation in fault setting, it is most important that the tests described in the Operating Recommendations under the heading "Overall fault setting tests" should first of all be done without the pilot supervision in service. This will not only check the basic fault setting but also confirm that the connections to the summation transformer at each end of the feeder are correct thus ensuring that the protection will stabilise correctly for external faults.

At the supervision receive end disconnect the supervision receive relays from the pilots and connect temporary links in the pilots to complete the pilot loop.

Do the overall fault setting tests at both ends of the feeder as described in the appropriate section of the Operating Recommendations.

If guard relays are fitted and sufficient test current is available the setting of the guard relays may also be checked by primary injection.

If it is convenient to permit operation of the circuit breaker at this stage, repeat one of the tests with the trip links inserted. If guard relays are fitted check that the circuit

breaker will not trip until both the guard relay and Solkor relay have operated.

At the conclusion of the tests, remove the temporary links from the pilots and re-connect the transformer-rectifier supply unit and the supervision receive relay in the pilot loop.

The pilot supervision supply may be switched on and, if desired, the overall fault settings re-checked with the supervision equipment in service.

**Tests of pilot supervision relays**

**Check of pilots supervision receive relay**

Disconnect the pilot supervision receive relay from the pilots and using the test circuit shown in Fig 7a check the pick-up and drop-off value of the relay.

The pick-up value of the relay should not exceed 3.5 milli-amperes.

The drop-off value of the relay should be less than 1.5 milli-amperes

**Test of guard relays (where fitted)**

If it has not been possible to check the operation of the guard relays by primary injection then the following tests should be done.

Connect a temporary short circuit across the CT's at both ends of the feeder. Disconnect the red phase guard relay from the CT secondary at one end of the feeder.

Using the test circuit shown in Fig. 7b, check the pick-up

value of the relay at the chosen setting.

Slowly reduce the current until the relay resets. The rest value should be greater than 75% of the pick-up value.

Repeat these tests for all the guard relays at both ends of the feeder.

At the conclusion of the tests, re-connect the guard relays on the C.T. secondaries and remove the short circuit from the C.T.'s at both ends of the feeder.

**Test of pilot supervision supply failure relay (where fitted)**

Disconnect the supervision supply failure relay from the transformer-rectifier supervision supply unit.

Using a variable a.c. voltage supply, check the pick-up value of the relay.

Slowly reduce the voltage until the relay resets.

The pick-up value of the relay should be approximately 80% of nominal rating.

**Overall tests of pilot supervision equipment**

Check that the pilot supervision equipment is connected correctly to the pilots and that all other connections are normal.

Connect a d.c. milli-ammeter in series with the pilot supervision relay.

Check that the a.c. supply to the transformer rectifier supply unit is connected to the correct transformer tapping.

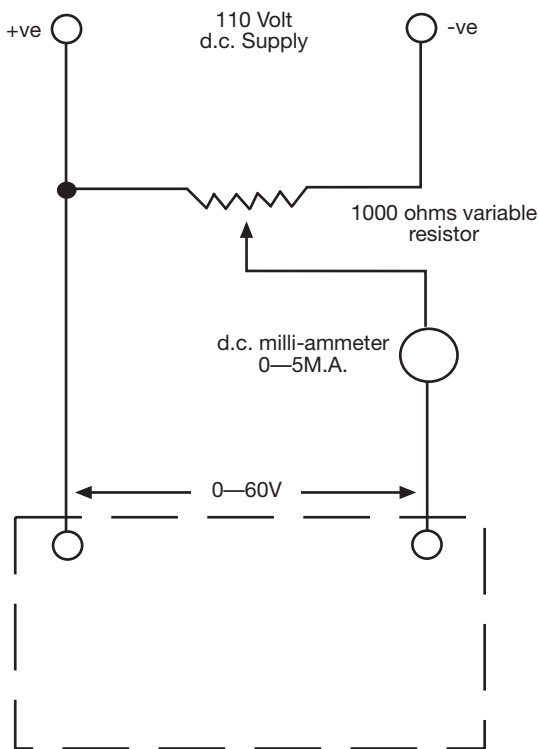

**Fig. 7a Secondary injection test of pilot supervision receive relay.**

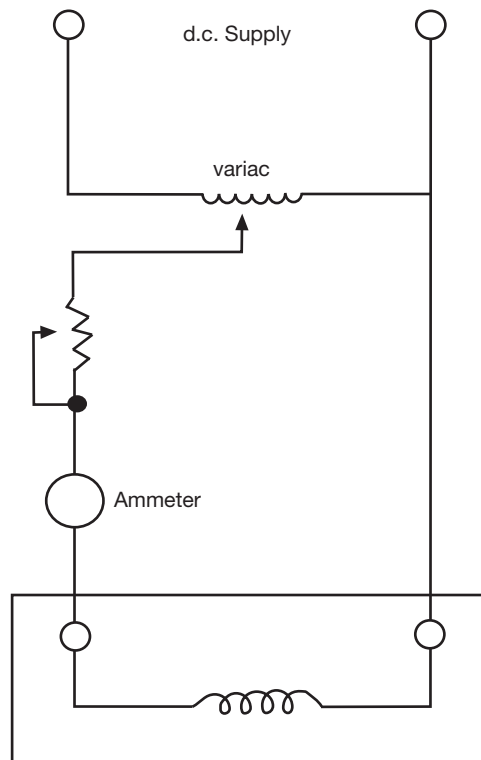

**Fig. 7b Secondary injection test of guard relays. (Refer to relevent schematic for terminal nos.).**

Switch on the a.c. supply to the transformer rectifier supply unit.

Check that the pilot supervision receive relay operates and that the current recorded by the d.c. milli-ammeter in the pilots is not less than 4 milli-amperes.

Check the correct operation of the scheme by doing the following tests:-

- Short circuit the pilots and check that the pilot supervision receive relay and its follower relay reset and that a correct pilot failure alarm is given.
- Open circuit the pilots and check that the pilot supervision receive relay and its follower relay reset and that a correct pilot failure alarm is given.
- Reverse the pilots at one end of the feeder and check that the pilot supervision receive relay does not pick-up and that a correct pilot failure alarm is given. Check that the current recorded by the d.c. milli-ammeter in the pilots is less than one milli-ampere.

Remove the d.c. milli-ammeter from the pilots and restore all connections to normal.

### Stability tests

Check the stability of the protection as described in the appropriate Operating Recommendations.

### PUTTING INTO SERVICE

Make a final check of connections. Ensure that the supervision supply is switched on, that the pilot supervision receive relay and repeat relay are held operated and that all indications and alarms are reset.

Make the checks described under the heading "Putting into service" in the appropriate Operating Recommendations.

Finally insert the tripping links.

### NOTES

Current transformer connections are typical only.

Earthing connections are typical only.

5kV Solkor Rf schemes omit the 15kV isolating transformers

Solkor R connections are shown in the relay Installation Recommendations.

An "R" above the connections indicates the Epsilon or Reymos case terminal numbers.

A "V" above the connections indicates the Vadette case terminal numbers.

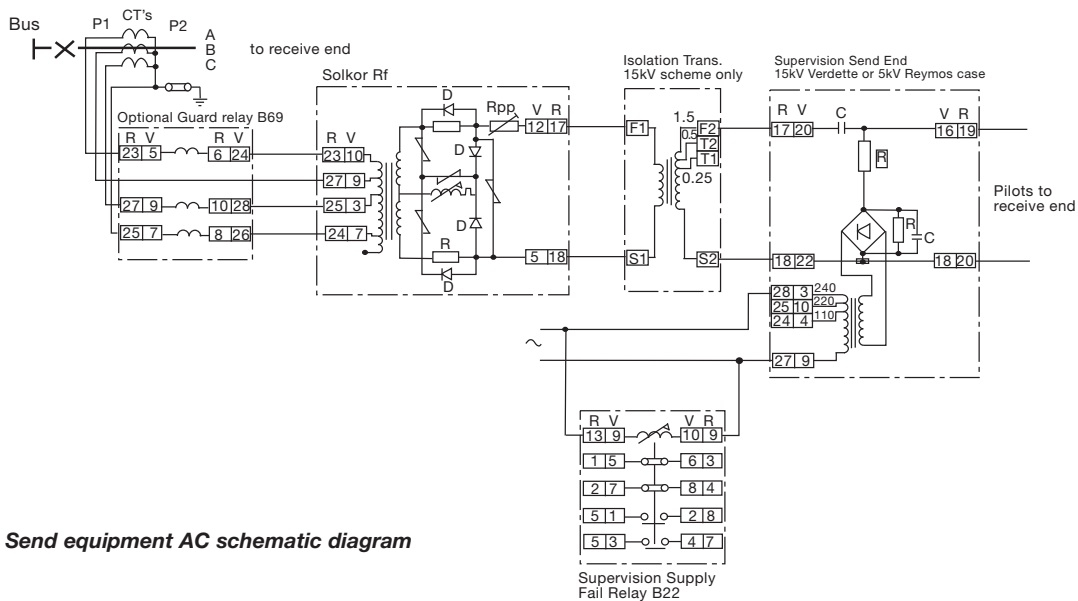

Send equipment AC schematic diagram

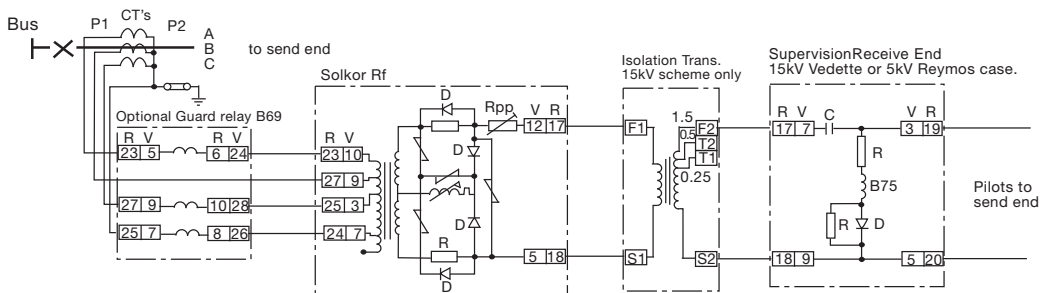

Receive equipment AC schematic diagram

Fig. 8 Solkor protection with pilot supervision.

## SOLKOR INTERTRIPPING

### APPLICATION

Solkor provides double ended tripping for in-zone faults. Use can also be made of the Solkor pilot link, and the remote Solkor relay, to intertrip the remote circuit breaker for example to backtrip from a busbar or transformer protection. There are several possible methods available, the choice between them being dependant upon the current available through the protected feeder for the fault conditions which required intertripping.

### DESCRIPTION

#### Open circuiting of pilots - Solkor-R and Solkor-Rf

Since Solkor protection is a current balance scheme, fault current intertripping can be effected by open circuiting the pilot loop. The magnitude of the current required through remote current transformers to cause operation of the relay depends somewhat on the intercore capacitance of the pilot line. For reliable intertripping the minimum fault current through the remote current transformers should not be less than twice the nominal fault setting for each type of fault.

#### DC injection intertripping

Solkor R may also be intertripped by the direct application of a 110V dc voltage source to the local end of the pilots. This d.c. may be derived from a 5kV or 15kV isolated intertripping battery or from a secure full wave rectified



110V, 50/60Hz, voltage derived from a 5kV or 15kV isolation transformer.

#### Injection intertripping - Solkor-R & Solkor-Rf

Injection intertripping is used where decisive intertripping is required, irrespective of the current in the protected feeder, and to avoid possible interaction between the injected signal and power frequency voltages. Its use also avoids

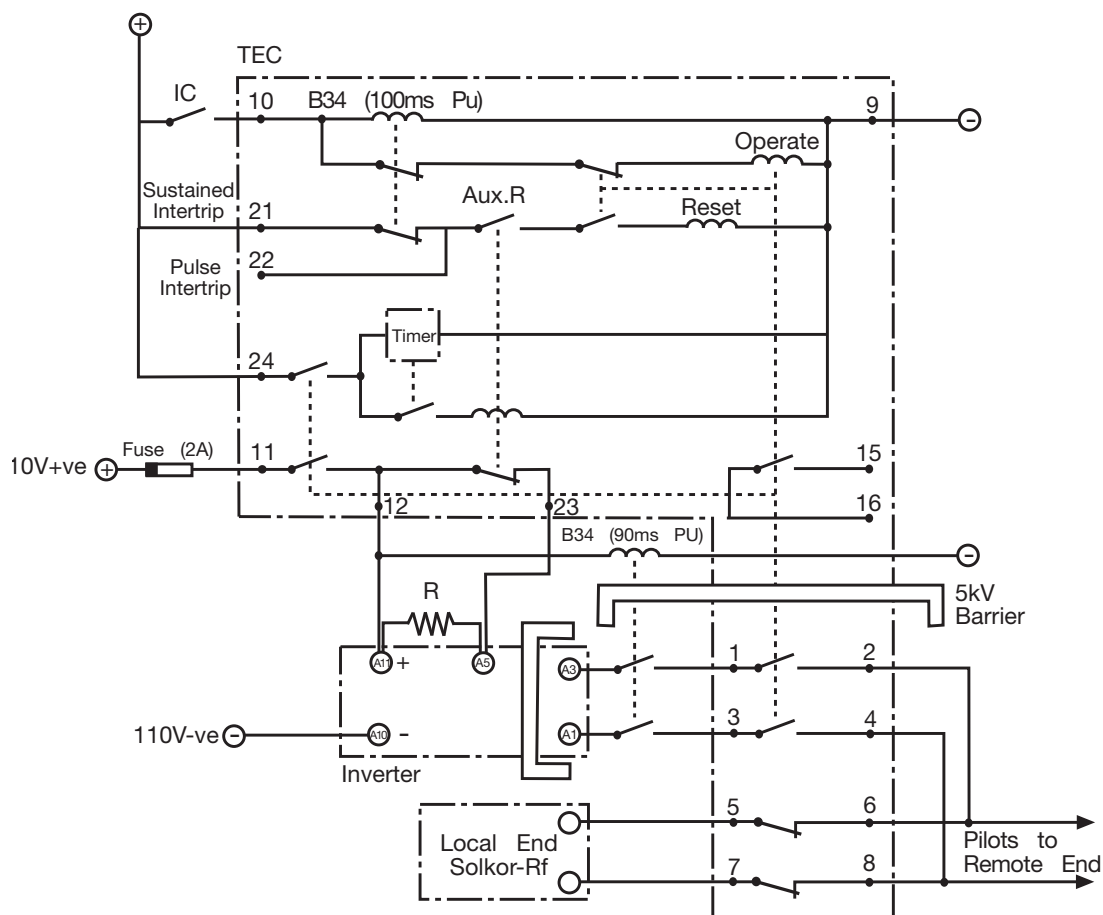

Fig. 9 Typical 2 stage sustained intertripping scheme for Solkor-Rf. send end.

the requirement for 5kV or 15kV insulated intertripping batteries.

Injection intertripping is not suitable for use with guard relays (which place normally open contacts in series with the Solkor relay contact) or for Solkor-R with Supervision applied to the same pilots, (for such schemes Supervision may be carried out over spare cores). Due to a different inverter being required, Solkor-Rf can use both injection intertripping and supervision over the same pilots.

The send equipment comprises an inverter and a type TEC relay to switch the a.c. intertripping signal, Solkor-Rf requires an additional time delay relay. The receive relay is the remote Solkor relay. It is unnecessary to continuously energise the inverter, normally a full power signal is sent for 2 secs, followed by either de-energisation of the inverter or by a reduced inverter output which holds the remote relay operated, see fig 9.

**Note applicable to all schemes:-**

Where contacts are directly connected to the pilot wires then 5kV/15kV isolation must be maintained from earth and other circuits. For more details of schemes contact Reyrolle Protection.

**COMMISSIONING**

This publication gives details of the tests necessary to prove that the Solkor Rf injection intertripping equipment using a type TEC relay and a D.C./ A.C. inverter has been installed and is operating correctly.

For connections of the equipment reference should be made to the appropriate schematic diagram.

Tests of the Solkor Rf protection should be done separately as detailed in leaflet OR/R.

**Description of operation of TEC relay**

Operation of the intertrip send initiating contact causes the multi-contact, electrically reset type F element to operate and this immediately open circuits the pilots on the local-end relay side and connects the injection supply across the pilots. The contacts on the pilot side are insulated to withstand a voltage of 5kV or 15kV to earth.

At the same time a type B relay element is energised and

after 100 milli-seconds a contact on this relay isolates the operate coil circuit of the multi-contact type F element.

After 2 seconds a type TCD timing relay which is energised from a contact on the type F element resets the type F element thus disconnecting the injection supply.

A two second intertrip pulse is therefore given irrespective of whether the initiating contact is self or hand reset. If the initiating contact is self reset the TEC relay resets completely but if it is hand reset the type B element remains energised until the initiating contact is reset.

**Check on D.C/ A.C. inverter**

Remove external connections from inverter terminals A1, A3.

Connect a 20 watt 2000 ohm resistor across terminals A1 and A3. Arrange the test circuit as shown in Fig.10.

Measure the, input voltage and the voltage across the 2000 ohm resistor.

Check that the output voltage across the 2000 ohm resistor is within the limits shown in Fig 11.

Check that the input current does not exceed 2 amps D.C.

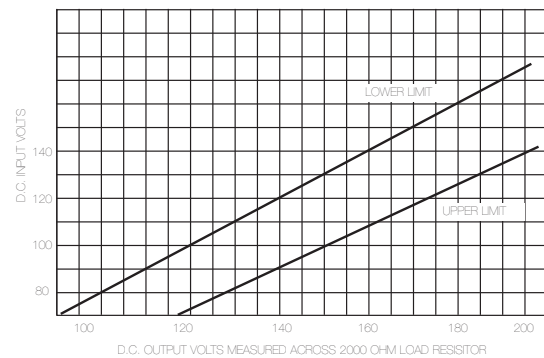
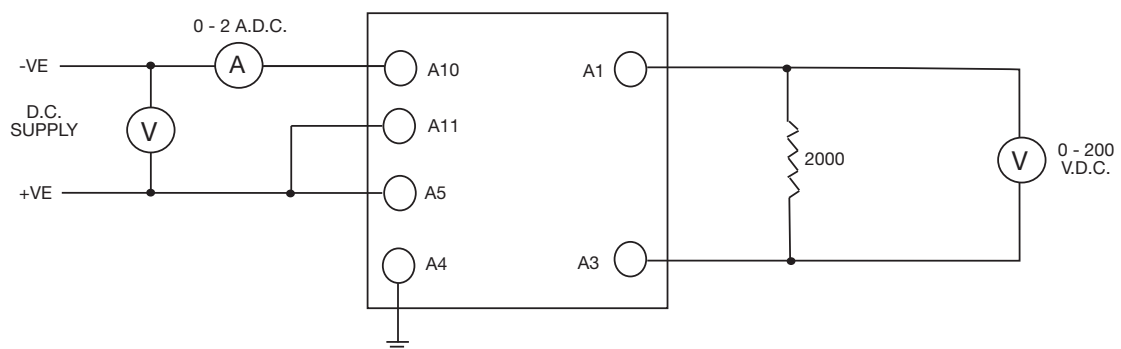

**Fig. 11 D.C./A.C. Inverter (Art No. 410A21535).**

**PUTTING INTO SERVICE**

Restore all connections to their correct terminals. Insert D.C. supply links and fuses and intertrip links.

Operate the intertrip send initiating contact at each end. Check that the remote end relay operates and that the correct alarms and indications are given.



**Fig. 10 Test circuit inverter.**

**Austria**

VA TECH Elin GmbH  
Penzinger Strasse 76, P.O.B. 5  
A - 1141 Vienna, Austria  
Tel: ++43 1 89 100  
Fax: ++43 1 89 100 196  
Telex: 112763 elin a  
E-mail: contact@eev.elin.co.at

VA TECH SAT Systeme  
FÜR AUTOMATISIERUNGSTECHNIK  
GMBH Ruthnergasse 1  
A - 1210 Vienna, Austria  
Tel: ++43 1 29 129  
Fax: ++43 1 29 28 838  
Telex: 112763 sat a  
E-mail: ha@sat-automation.com

**United Kingdom**

VA TECH Reyrolle ACP Ltd,  
PO Box 8, North Farm Road, Hebburn,  
Tyne & Wear, NE31 1TZ, UK  
Tel: ++44 191 401 1111  
Fax: ++44 191 401 5575  
Email: marketing.acp@vatechuk.com

**Australia**

VA TECH Australia Pty Ltd,  
Unit 1/7 Anzed Court,  
(PO Box 4155),  
Mulgrave, Victoria,  
Australia, 3170  
Tel: ++61 3 9264 9988  
Fax: ++61 3 9574 9556  
Email: vatechaustralia@bigpond.com.au

**Hong Kong**

VA TECH Elin Reyrolle Limited  
Unit 1903-4, 19F CC Wu Building  
302-308 Hennessy Road  
Wan Chai  
Hong Kong  
Tel: ++852 2891 6362  
Fax: ++852 2893 4360  
Email: colinwo@vatech.com.hk

**India**

Easun Reyrolle  
Plot 98  
Sipcot Industrial Estate  
Hosur 635126  
Tamil Nadu, India  
Tel: ++91 4344 76895  
Fax: ++91 4344 76397  
Email: hosur@easunreyrolle.com

**Middle East**

VA TECH Reyrolle ACP Ltd  
PO BOX 2621  
Abu Dhabi  
Tel: ++97 12644 0650  
Fax: ++97 12644 4950  
Email: jcleach@emirates.net.ae

**Netherlands**

Electron Automation B.V.  
Takkebijsters 17-1  
NL 4817 BL BREDA  
Tel: ++31 76 573 8430  
Fax: ++31 76 573 8430  
Email: electron@sat-automation.com

**New Zealand**

VA TECH Reyrolle Pacific Ltd  
Private Bag 39811  
Wellington Mail Centre  
New Zealand  
Tel: ++64 4 568 3499  
Fax: ++64 4 569 9688  
Email: sales@reyrolle.co.nz

**Poland**

Luxtel S C  
43-100 Tychy  
Aleja Blejska  
Poland  
Tel: ++48 3232 64185/6  
Fax: ++48 3232 64188  
Email: luxtel@ka.onet.pl

**South Africa**

Reyrolle South Africa Ltd  
Corner Barbara and North Reef Roads  
PO Box 8080  
Elandsfontein 1406  
Gauteng  
Republic of South Africa  
Tel: ++27 11 828 0170  
Fax: ++27 11 828 0943  
Email: wzeelie@reyrolle.co.za

**South East Asia**

VA TECH SAT Sdn Bhd  
Company No.414225 K  
No.15, Jalan BRP 9/1D  
Perusahaan Bukit Rahman Putra  
47000 Sungai Buloh  
Selangor Darul Ehsan  
Malaysia  
Tel: ++603 6157 8050  
Fax: ++603 6157 8060  
Email: loreen@sat-automation.com

**We have the following range of publications:**

- Product & system range ordering catalogue
- Technical manuals
- Brochures on all major product ranges
- Application guides

Training courses also available.

For more details contact our Marketing Department

Tel: ++44 191 401 1111

