

## VA TECH Transmission and Distribution

### VA TECH Reyrolle ACP Ltd

## Argus 1 – Overcurrent protection relays: AG1 - 431 to 434

### Features

- Multiple independent protection characteristics per pole, including IDMTL, DTL, a transient free lowset and two transient free highsets.
- True RMS measurements over a wide frequency range.
- Ammeter displays – I, I<sub>max</sub> & Rolling demand per pole & Neutral/Earth ammeter.
- General Alarm – latched, user text alarm message.
- CT Supervision.
- Circuit Breaker Fail – Two stage DTL with Phase & Earth settings.
- External Trip input mapped via Status Input.
- Counters and Alarm settings.
- Stores 5 Fault Data records.
- Trip circuit supervision H6 and H7 schemes.
- Instantaneous or delayed reset characteristic allowing detection of flashing fault conditions.
- Programmable output contacts and status inputs.
- User-friendly settings and indications.
- Stores 500 time-tagged event records.
- Stores 5 waveform records.
- Serial communications conforming to IEC870-5-103, FT1.2 with fibre optic interface for superior EMC performance or MODBUS RTU via RS485 multi-drop electrical bus.
- Self-monitoring capability.

### Description

The Argus range of numeric overcurrent protection devices combine the power and flexibility of microprocessor technology with decades of experience in the field of overcurrent protection. A wide range of protection elements and characteristics are supplemented by advanced features such as metering, data storage and test functions.

Supervisory components and self-monitoring algorithms give high confidence of full serviceability. A menu-based interface gives user-friendly access to relay settings, meters and fault data.

This Argus 431-434 range consists of four-pole (3P+E) numeric overcurrent relays. These compact units are housed in withdrawable size E4 cases.

The serial communications interface allows retrieval of waveform, fault information and event record data files. On-line polling allows remote access to metering values.

A trip counter and I<sup>2</sup> summation feature provides information for circuit breaker condition based maintenance.

Settings can be viewed or altered remotely, with security provided by a password feature. Eight independent settings groups are available and may be selected manually or remotely.



Up to 254 Argus relays can be connected together in a network and addressed directly.

### Technical information

**Rating** 1A or 5A, 50/60Hz

**Auxiliary supply** 24/30/48Vdc 110/220Vdc  
NB. 110V or 220V ESI 48-4 Status inputs require external resistors. 110V or 220V low burden, direct status inputs are available.

### Settings

Phase fault	0.05xIn to 2.5xIn Δ 0.05xIn
Earth fault	0.05xIn to 2.5xIn Δ 0.05xIn
Highsets 1&2	0.05xIn to 2.5xIn Δ 0.05xIn 3.0xIn to 52.5xIn Δ 0.5xIn
Lowset	0.05xIn to 2.5xIn Δ 0.05xIn 3.0xIn to 52.5xIn Δ 0.5xIn
Definite time	0s to 300s
Time multiplier	0.025 to 1.6 Δ 0.025
Reset delay	0s to 60s Δ 1s

# Argus 1 – Overcurrent protection relays: AG1 - 431 to 434

## IDMTL curves

Operate times can be calculated as follows:

$$I = \frac{K}{\left[ \frac{I}{I_s} \right]^\alpha - 1} \times T_m$$

where I = fault current, I<sub>s</sub> = current setting, T<sub>m</sub> = time multiplier,

NI - K = 0.14, α = 0.02

VI - K = 13.5, α = 1.0

EI - K = 80.0, α = 2.0

LTI - K = 120.0, α = 1.0

## Output Contacts

The basic relays contain 5 programmable output relays, 2 of which have 1 CO contact and 3 have 1 NO contact. By default, the relay 1 NC contact may be used for the protection healthy function.

## Contact ratings

Carry continuously 5A ac rms or dc.

Make and carry 30A ac or dc for 0.2sec.

Break 75W dc resistive.

1250VA ac resistive.

## Status Inputs

These relays provide 3 programmable status inputs each with Inversion, Pick-Up delay and Drop-Off delay / latched operation. Inputs can be User mapped to internal control functions as output relays.

Inputs are arranged as 1 Isolated + 2 with shared common (negative) input.

## Indication

Green LED - Protection healthy.

Yellow LED - Starter indication.

Red LED - Trip.

LCD - Alphanumeric displays for settings, instruments and fault data.

## Burdens

AC (Phase/Earth) < 0.2VA at I<sub>n</sub>.

DC (Typical) 5W.

## Environmental

### Temperature

IEC 68-2-1/2

Operating range

-10°C to +55°C

Storage range

-25°C to +70°C

### Humidity

IEC 68-2-3

56 days at 40°C and 95% rh.

### Vibration

IEC 255-21-1 class I

### Shock and bump

IEC 255-21-2 class I

### Seismic

IEC 255-21-3 class I

### Insulation

IEC 255-5

2kVrms for 1 minute between all terminals and earth.

2kVrms for 1 minute between independent circuits.

1kVrms for 1 minute across NO contacts.

### Transient overvoltage IEC 255-5 class III

5kV 1.2/50µs between all terminals and earth without damage or flashover.

### High frequency disturbance IEC 255-22-1 class III

2.5kV common mode < 3% deviation.

1.0kV series mode < 3% deviation.

### Electrostatic discharge

IEC 255-22-2 class III

8kV direct without maloperation or damage.

### Radio frequency disturbance IEC 255-22-3

20MHz to 1GHz at 10V/m < 5% deviation.

### Fast transient

IEC 255-22-4 class IV

4kV 5/50ns < 3% deviation.

## Ordering information

### PSU

### Status

AG1-431 3P+E 1A 30/48V 48V

AG1-432 3P+E 5A 30/48V 48V

AG1-433 3P+E 1A 110/220V 48V

AG1-434 3P+E 5A 110/220V 48V

RS485 electrical bus, direct 30V and low-burden 110V and 220V Status inputs are all available on request.

## Qualifications

VA TECH Reyrolle-Protection operate a quality system accredited to ISO9001.

CE Compliant to relevant EU Directives.

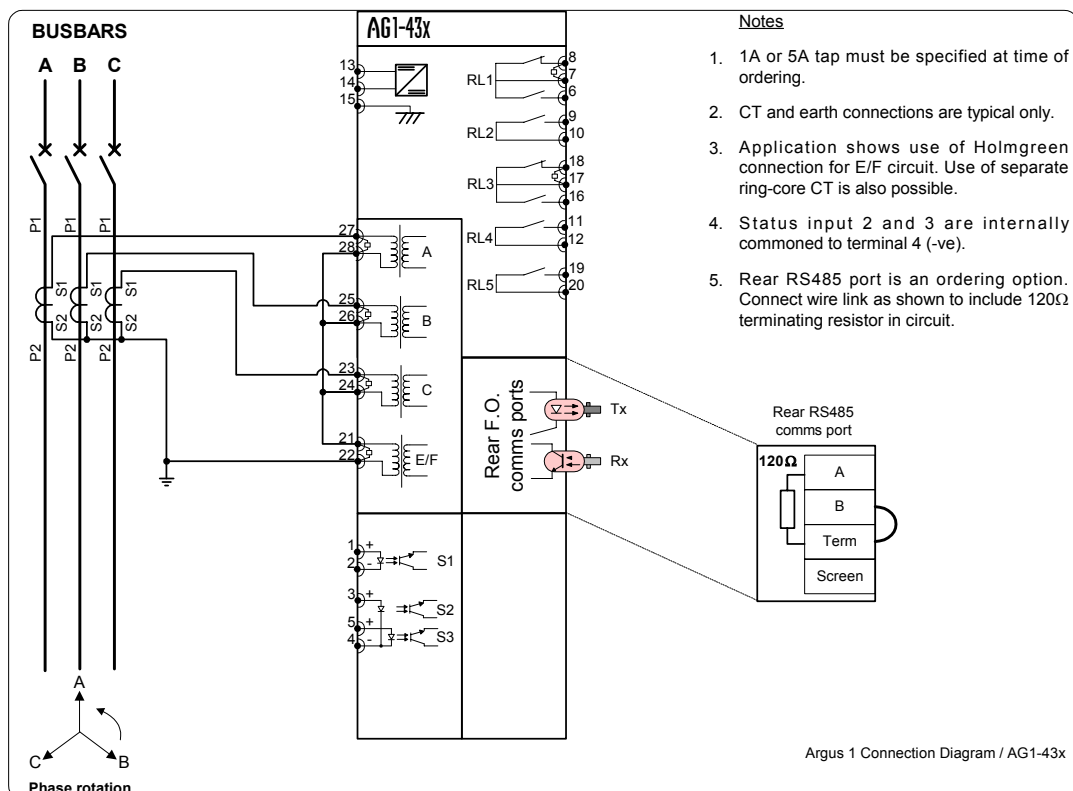

## VA TECH Transmission & Distribution

VA TECH Reyrolle ACP Ltd. PO Box 8, North Farm Road, Hebburn, Tyne & Wear NE31 1TZ, England

T: +44 (0)191 401 7901. F: +44 (0)191 401 5575. E: marketing.acp@vatechuk.com.

W: www.reyrolle-protection.com

REYROLLE