

Normal inverse IDMT relays type 2TJM13 and 2TJM73

Features

- Substation battery supply not required
- Easy to test and maintain
- Complies with BS142 Sections 2.2 and 3.2 (1990) and applicable IEC 255 specifications

The range is as follows:

- 2TJM13 Normal inverse IDMT form 3/10
- 2TJM14 2TJM13 with MCAA highset element
- 2TJM73 Normal inverse IDMT form 1.3/10
- 2TJM74 2TJM73 with MCAA highset element

Application

Series a.c. tripping does not require a d.c. auxiliary supply; tripping is effected by switching the C.T. secondary current to the circuit breaker trip coil when the relay completes its operation. The normally closed contacts which carry out this duty are suitably rated for the high secondary currents associated with system faults.

The normal inverse characteristic is based on IEC 255-4, BS142, 3.2, generally applied in time/current graded schemes for overcurrent and earth fault protection.

Description

The relay comprises a die-cast frame which carries all the relay sub-assemblies of induction disc, electro-magnetic system, operating coil, plug bridge, IDMT contact assembly, a.c. series tripping and, if required, highset elements.

The electro-magnetic system comprises primary and secondary magnets arranged with four air gaps each contributing to the driving torque. The primary coil, with tappings to permit the selection of a fault setting by a plug-bridge, energises the primary magnet and a secondary winding which energises the secondary magnet. The plug-bridge automatically selects the highest setting when



Type 2TJM14 single pole relay in a vedette chassis

the setting-plug is withdrawn. A rectifier operated B33 element with hand reset contacts provides the heavy duty break contact required for a.c. series tripping.

The relay operating time is determined by the starting position of the induction disc, this is set by the time multiplier dial calibrated from 0.1 to 1.0. There is also a "T" mark, before the 0.1 setting and in this position the contacts are held closed, locked out. Settings are applied in amps.

$$I_S = I_n \times M1 \times M2$$

where,

- I_S = Set current
- I_n = Relay nominal current rating
- M1 = Plug setting
- M2 = A marked multiplying factor

Technical information - IDMT

Rating I_n	1A or 5A
Setting I_S	(7 settings in equal current steps) 20% to 80% in 10% steps or 50% to 200% in 25% steps
Burden	Approximately 3VA at I_S
Time multiplier	0.1 to 1.0, continuously adjustable with 0.05 calibration markings

Normal inverse IDMT relays type 2TJM13 and 2TJM73

Pick-up Not greater than 130% of I_S
 Reset Not less than 95% of I_S
 Typical reset time 14s ($T_M = 1.0$
 and current switched to zero)

Overshoot Less than 80ms
 Indication Hand reset flag

Technical information - Highset element

Burden 1-2VA over setting range
 Operating time 20ms at $2 \times I_S$, 12ms at $5 \times I_S$
 Setting ranges (1A or 5A)

400% to 1600%
 800% to 3200%
 1000% to 4000%

Indication Hand reset flag

Contacts for external use

Heavy duty 1 normally closed (2 in parallel) hand reset
 Contact rating Break 150A at 150Va.c
 Normal duty 2 normally open hand reset
 Contact rating Make and carry 1500VA a.c. or d.c. with
 limits of 600V and 3A continuously, or 8A
 for 3 seconds or 16A for 1 second.
 Break 300VAa.c. or 75Wd.c. ($L/R = 0.04$)
 with limits of 250V and 5A

Accuracy (IDMT)

Reference conditions

Time multiplier 1.0
 Reference tap $M1 = 2$
 Reference multiple $10 \times I_S$

Accuracy timing characteristic

Complies with the requirements of IEC 255-4 and BS142. The reference limiting error is the assigned/declared error of 7.5% within the effective range 2x to 20x setting.

Limits of influencing quantities and factors

The limits shown in BS142 Section 2.2 (1990) table 3 apply, additionally frequency can also be 56Hz to 62Hz and ambient temperature has an increased range of -25°C to +55°C.

Environmental

Temperature IEC 68-2-1 & 2
 Operating -25°C to +55°C.
 Storage -25°C to +70°C.
 Humidity IEC 68-2-3
 56 days at 95% RH and +40°C.

Insulation IEC 255-5

Relays will withstand:

5kV 1.2/50 μ s 0.5j between all terminals and case earth and between adjacent terminals.
 2kV rms 50Hz for 1 minute between all case terminals connected together and the case earth and between independent circuits.
 1kV rms 50Hz for 1 minute across normally open contacts.

Cases

Single pole vedette size 1V or 3 pole size 3H.

Ordering information

Model, setting range or ranges, single or three pole.

Qualifications

VA TECH Reyrolle-Protection operate a quality system accredited to ISO9001.

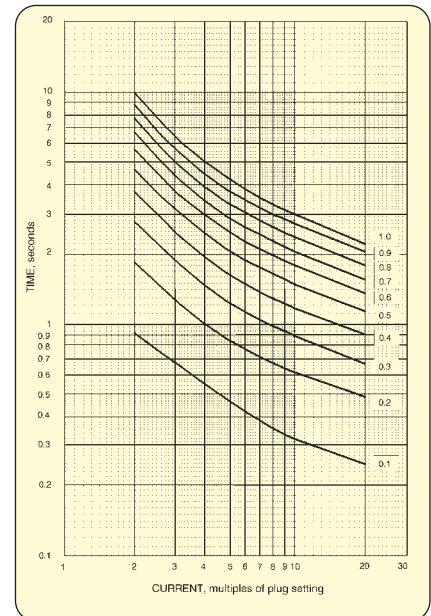

Fig. 1. Time/current characteristic form 3/10

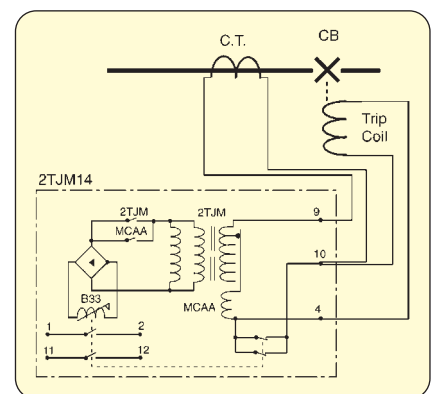

Fig. 2. Typical wiring diagram for a single element 2TJM14 and 2TJM73 relay. (2TJM13 and 2TJM74 are similar but without the MCAA highset element)