

Features

- High speed operation
- High burden
- Hand & electrical reset contacts
- Independent hand reset flag
- 5 or 10 contacts
- Equivalent function to MVAJ25

Application

The effect of a fault on a power system is dependent on the speed with which the fault can be detected & isolated. The 6RJ Series multi-contact high-speed trip relays are used for this isolating function providing simultaneous tripping outputs.

A high speed coil provides fast operation (<10ms at nominal voltage including bounce), with specially constructed anti bounce buffers ensuring effective damping of the contacts to avoid excessive bounce.

High Burden Trip Relay

The 6RJ25 is a high burden relay suitable for application in high security circuit breaker tripping circuits & in particular where the initiating contact may be remote from the relay. The high burden may also allow the satisfactory operation of external series elements.

The 6RJ21 has a high burden to provide immunity to capacitance discharge currents & power to the coil is cut off at operation or is economized to a low figure to provide thermal protection.

High burden tripping relays are designed to withstand the 10uF capacitor discharge test such that the relay will not operate when a 10uF capacitor charged to 120% of nominal operating voltage is applied across the coil of the relay.

Series Elements

External relay elements are often employed for additional flagging & alarm functions. These elements are typically much slower than the primary high speed tripping relay so care must be taken to ensure reliable operation of the series element before the series trip signal is cut off or economized. In these circumstances a 2HSM relay with a time delayed (TD) cut off should be employed.

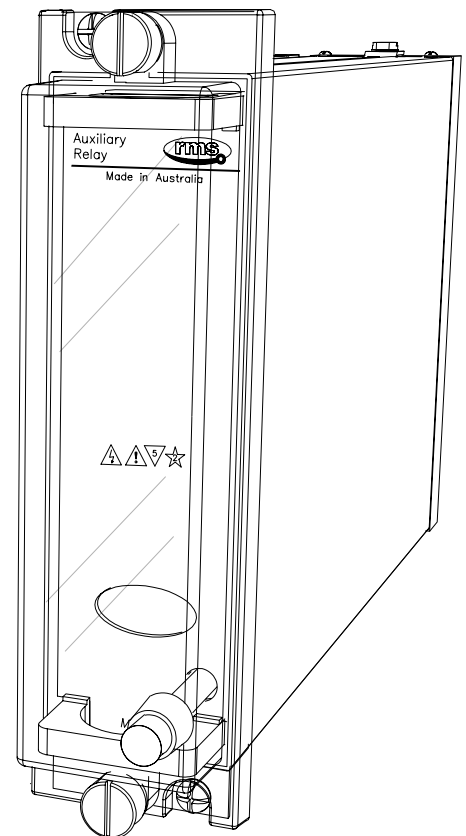

2M28 draw out case

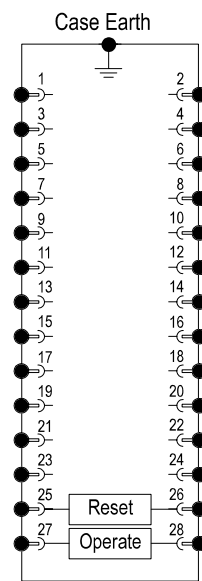

Case terminations (REAR VIEW)

6RJ25-5 Terminal Numbers					
Contacts	1-3	2-4	5-7	6-8	9-11
5M	M	M	M	M	M
4M+1B	M	M	M	M	B
3M+2B	M	M	M	B	B
2M+3B	M	M	B	B	B
1M+4B	M	B	B	B	B
5B	B	B	B	B	B

6RJ25-10 Terminal Numbers										
Contacts	1-3	2-4	5-7	6-8	9-11	10-12	13-15	14-16	17-19	18-20
10M	M	M	M	M	M	M	M	M	M	M
9M+1B	M	M	M	M	M	M	M	M	M	B
8M+2B	M	M	M	M	M	M	M	M	B	B
7M+3B	M	M	M	M	M	M	M	B	B	B
6M+4B	M	M	M	M	M	M	B	B	B	B
5M+5B	M	M	M	M	M	B	B	B	B	B
4M+6B	M	M	M	M	B	B	B	B	B	B
3M+7B	M	M	M	B	B	B	B	B	B	B
2M+8B	M	M	B	B	B	B	B	B	B	B
1M+9B	M	B	B	B	B	B	B	B	B	B
10B	B	B	B	B	B	B	B	B	B	B



OPERATING BURDEN (Burden during pick up at nominal)
 High burden relays: 150W Maximum
 Reset coils: <40W Maximum

OPERATED BURDEN (Burden after pick up at nominal)
 Hand reset contacts: Zero
 Reset coils: Zero

COIL THERMAL RATING
 The operate circuit is designed to withstand continuous application of 120% of nominal voltage. The high speed operate coil element (150 watt max.) has a thermal rating of 30 seconds, however this is protected by use of the instantaneous series cut-off contact arrangement.

OPERATING TIME
 Less than 10ms at nominal rated operating voltage.

CONTACT OPERATION
 Latching contacts with front panel hand reset button & reset coil remote electrical reset.

FLAG OPERATION
 Drops on coil energisation.
 Hand reset.

OPERATING VOLTAGE RANGE
 Guaranteed operation between 65% & 120% of nominal rated operating voltage.

NOMINAL OPERATING VOLTAGES
 24, 32, 48, 110, 125 & 250V DC available.

AC VOLTAGES
 Standard 6RJ relays are not intended for operation with AC voltages. Application of continuous AC voltage below the pick up level will cause excessive power dissipation in the capacitor discharge resistor & likely result in thermal damage to the device.

MINIMUM OPERATING CURRENT
 High burden relays: 100mA

CASE SIZE
 2M28 draw out case

CONTACTS
 5 or 10 contacts
 User to specify combination of make & break contacts

INSULATION WITHSTAND in accordance with IEC 255-5:
 2KV RMS & 1.2/50 5KV impulse between:

- ◆ all terminals & frame
- ◆ each contact group
- ◆ all contacts & coil

Ordering Codes

Generate the required ordering code as follows:
 e.g. 6RJ25-10-D-8M-2B



1 NUMBER OF CONTACTS

- 5 5 contacts
- 10 10 contacts

2 NOMINAL OPERATE VOLTAGE

- | | |
|----------|-----------|
| A 24V DC | D 110V DC |
| B 32V DC | E 125V DC |
| C 48V DC | F 250V DC |

3 CONTACT ARRANGEMENT (Not to exceed maximum)

Specify the number of "MAKES" followed by M; i.e. 8M
 Specify the number of "BREAKS" followed by B; i.e. 2B

6R RELAY CONTACT RATINGS

Make & Carry Continuously

3,000 VA AC resistive with maximums of 660V & 12A
 3,000 W DC resistive with maximums of 660V & 12A

Make & Carry for 3 Seconds

7,500 VA AC resistive with maximums of 660V & 30A
 7,500 W DC resistive with maximums of 660V & 30A

AC Break Capacity

3,000 VA AC resistive with maximums of 660V & 12A

DC Break Capacity (Amps)

Voltage	24V	48V	125V	250V
Resistive rating	12	2	0.5	0.25
L/R=40ms Maximum break	12	1	0.25	0.15

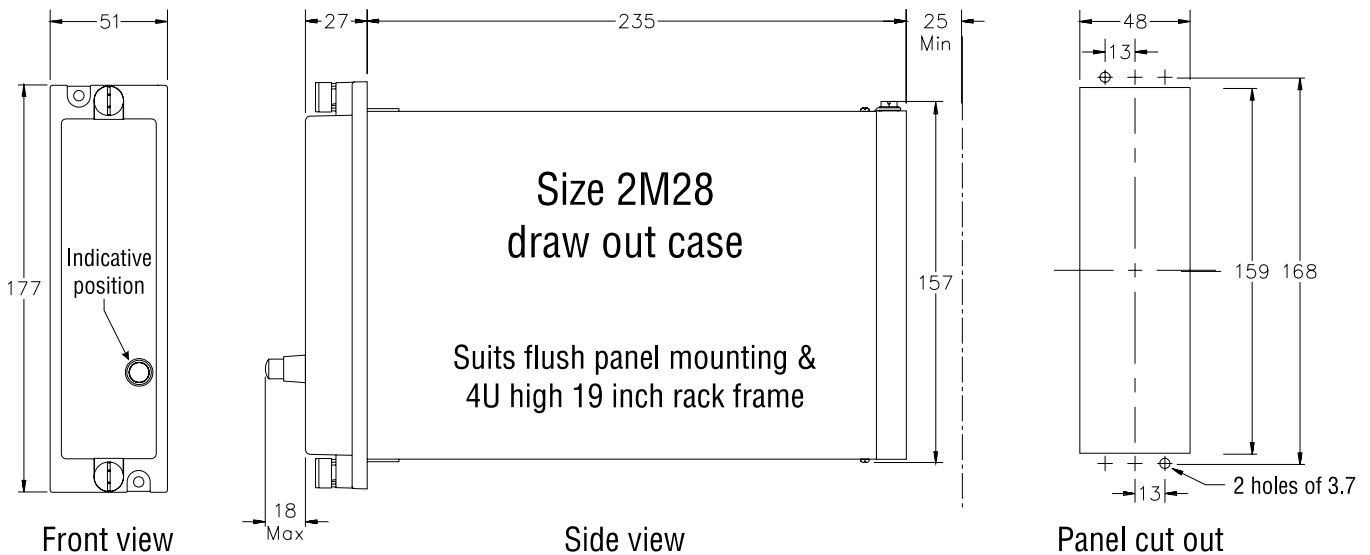

Visit www.rmspl.com.au for the latest product information.

Due to RMS continuous product improvement policy this information is subject to change without notice. 6RJ25/Iss. A/27/01/04/22



Australian Content

Unless otherwise stated the product(s) quoted are manufactured by RMS at our production facility in Melbourne Australia. Approximately 60% of our sales volume is derived from equipment manufactured in house with a local content close to 90%. Imported components such as semi-conductors are sourced from local suppliers & preference is given for reasonable stock holding to support our build requirements.

Quality Assurance

RMS holds NCSI (NATA Certification Services International), registration number 6869 for the certification of a quality assurance system to AS/NZS ISO9001-2000. Quality plans for all products involve 100% inspection and testing carried out before despatch. Further details on specific test plans, quality policy & procedures may be found in section A4 of the RMS product catalogue.

Product Packaging

Protection relays are supplied in secure individual packing cardboard boxes with moulded styrene inserts suitable for recycling. Each product & packing box is labeled with the product part number, customer name & order details.

Design References

The products & components produced by RMS are based on many years of field experience since Relays Pty Ltd was formed in 1955. A large population of equipment is in service throughout Australia, New Zealand, South Africa & South East Asia attesting to this fact. Specific product & customer reference sites may be provided on application.

Product Warranty

All utility grade protection & auxiliary relay products, unless otherwise stated, are warranted for a period of 24 months from shipment for materials & labour on a return to factory basis. Repair of products damaged through poor application or circumstances outside the product ratings will be carried out at the customer's expense.

Standard Conditions of Sale

Unless otherwise agreed RMS Standard Terms & Conditions (QF 907) shall apply to all sales. These are available on request or from our web site.



Relay Monitoring Systems Pty Ltd

6 Anzed Court, Mulgrave, Victoria 3170, AUSTRALIA

Tel: 61 3 9561 0266 Fax: 61 3 9561 0277 Email: rms@rmspl.com.au Web: www.rmspl.com.au