

## Features

- Detects phase angle imbalance
- Detects negative phase sequence
- Detects supply undervoltage
- Unaffected by frequency variations of  $\pm 5\text{Hz}$
- Adjustable 5-15% out of balance setting
- Range of detection voltages & frequencies available
- No auxiliary voltage required
- Fail safe operation (Contacts normally picked up)
- Filter rejects harmonics & control tones
- Size 2M28 draw out case
- Optional heavy duty contacts
- Optional mechanical flag indication
- Suitable for 3 phase voltage selection schemes
- Optional time delay on drop off
- Made in Australia

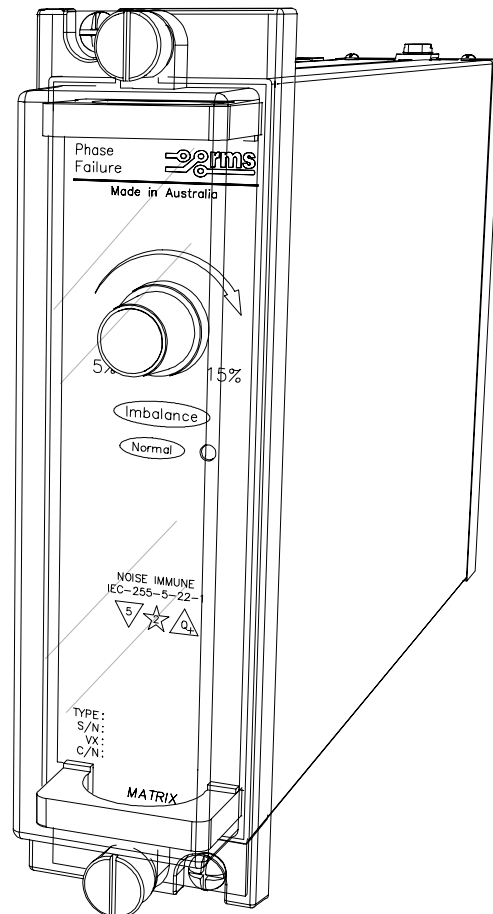

2P49 depicted in a 2M28 case

## Description

Made in Australia

The 2P49 relay is a 3 phase voltage monitoring relay suitable for the detection of excessive negative sequence voltage resulting from phase failure, phase unbalance and reversed phase sequence.

The 2P49 output relay provides fail safe operation in that its output contacts are normally energised & drop out when:

- ◆ Phase angle unbalance is greater than the front panel pre-set;
- ◆ 3 phase voltage falls below the factory pre-set of 80%;
- ◆ Reverse phase sequence.

## PRINCIPLE OF OPERATION

The unit consists of a simple RC circuit across the R-Y phase such that point x will only be at the same potential as point p for a balanced supply of correct phase sequence. The solid state relay circuit is designed to release the relay at either a set out of balance voltage (X-P voltage), or a set undervoltage of the B-W phase (relay supply). Special filtering circuitry is used to prevent high frequency or ripple control signals from affecting the operation of the relay.

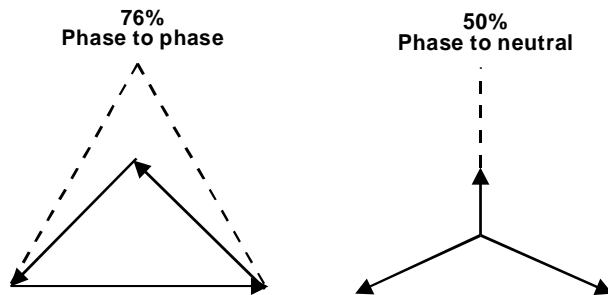
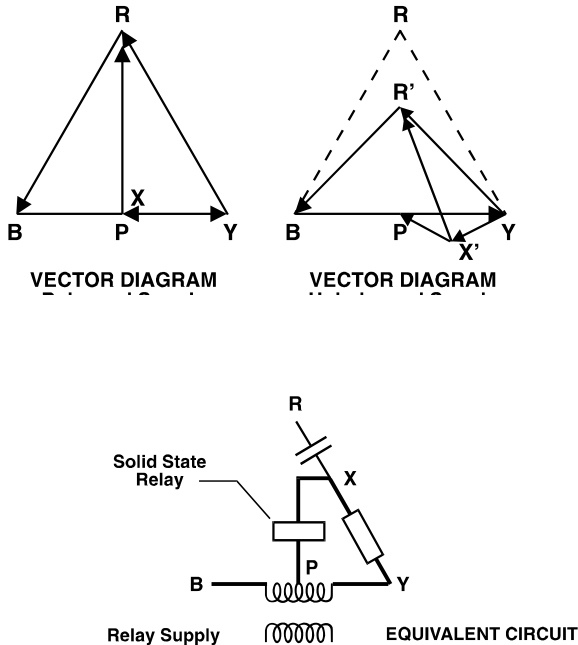

## PHASE REVERSAL PROTECTION

The 2P49 relay can be used for transportable cranes, refrigerated transporters, etc., which on being connected from one supply to another require phase reversal protection. The advantage of the 2P49 for this application is the added protection of phase failure and undervoltage.

## VOLTAGE SELECTION SCHEMES

The 2P49 relay can be applied in automatic voltage selection schemes to change over from a primary 3 phase supply to a secondary 3 phase supply if any phase of the primary supplies has faulted. A number of 2P49 relays may be cascaded to allow selection between 2, 3 or 4 independent 3 phase supplies.

For this application 4 C/O heavy duty contacts are required & the 2s time delay is recommended.

A single phase representation for automatic selection between multiple 3 phase supplies is depicted below:

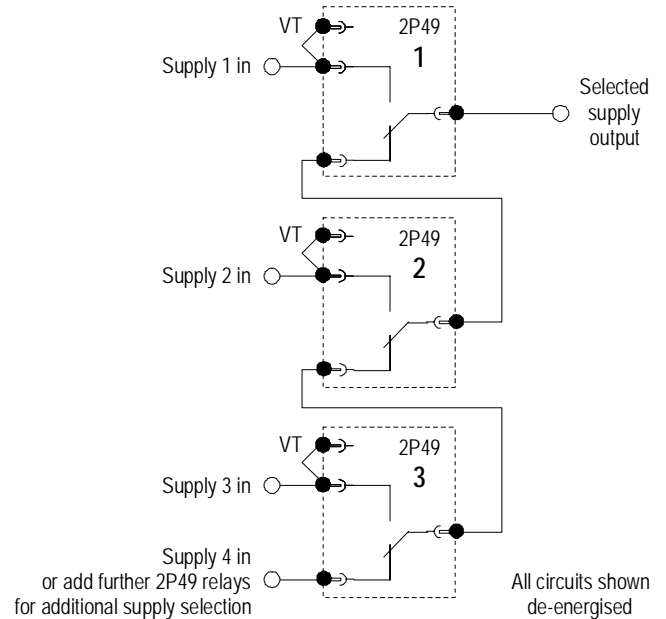

## MOTOR PROTECTION

The 2P49 phase failure relay has the sensitivity to detect the voltage unbalance caused by a motor single phasing. In most instances even a motor with no load and no other loads connected to the open phase will be detected when single phasing. The 2P49 relay is ideal for detecting phase failure and unbalance of HT lines and for this purpose 110V relays are also available. As the 2P49 detects the presence of negative sequence voltage a relay connected on the load side of a three phase transformer will detect a blown fuse or high impedance in one phase of the supply to the transformer, regardless of the transformer winding connections. Pump motors on the end of a HT line with fuse protection and therefore high probability of single line outages are an obvious application for the 2P49 relay.

## 3 PHASE UNDERVOLTAGE

It is a useful undervoltage relay in that phase angles are also monitored. As an example three single phase undervoltage relays may not detect an open phase which is connected to a healthy phase through a low impedance load. The 2P49 relay however will detect this condition due to the change in phase angles. In using the 2P49 relay as an undervoltage relay it must be remembered that only the B-W voltage is monitored directly. The other two  $\emptyset$  to  $\emptyset$  voltages are monitored for correct phase angle and voltage balance with respect to the B-W voltage. The difference in percentage undervoltage expressed as phase to phase and phase to neutral must also be appreciated. As a guide, when two  $\emptyset$  to  $\emptyset$  voltages are equally reduced as shown - the relationship is as follows:

- 95%  $\emptyset$  to  $\emptyset$  = 90%  $\emptyset$  to N
- 90%  $\emptyset$  to  $\emptyset$  = 80%  $\emptyset$  to N
- 85%  $\emptyset$  to  $\emptyset$  = 69%  $\emptyset$  to N

### IMBALANCE SETTING

Adjustable 5-15% expressed as phase to phase voltage difference as a % of nominal voltage when two phase to phase voltages are reduced equally with the third at nominal voltage.

The equivalent negative sequence voltage expressed as a % of nominal phase to neutral voltage would be 10-31%. (Other settings are available to order.)

### UNDERVOLTAGE SETTING

80% fixed - expressed as phase to phase voltage % of nominal voltage. (Other settings are available to order)

### ACCURACY

±2% of 5 - 15% of nominal

### STANDARD OUTPUT CONTACTS

2 C/O standard (Iddec RH type)

#### Maximum Contact Capacity (Amps)

Voltage	DC			AC		
	30	125	250	110	220	250
Resistive	10	2.4	1.2	10	7	6.6
Inductive L/R 7ms	7.5	1.8	0.9	7.5	5	4.4

#### Make & Carry for 200ms

30A at 250V DC resistive

#### Maximum Break Capacity

0.34A at 250V DC inductive (40ms)

### OPTIONAL HEAVY DUTY OUTPUT CONTACTS

4 C/O for voltage selection schemes

### 6R RELAY CONTACT RATINGS

#### Make & Carry Continuously

3,000 VA AC resistive with maximums of 660V & 12A  
3,000 W DC resistive with maximums of 660V & 12A

#### Make & Carry for 3 Seconds

7,500 VA AC resistive with maximums of 660V & 30A  
7,500 W DC resistive with maximums of 660V & 30A

#### AC Break Capacity

3,000 VA AC resistive with maximums of 660V & 12A

#### DC Break Capacity (Amps)

Voltage			24V	48V	125V	250V
Resistive rating	a	12	1.5	0.5	0.25	
	b	12	12	10	5	
L/R=40ms	Maximum break	a	12	1	0.25	0.15
		b	30	15	5.5	3.5
1K operations (N3 Rating)		a	12	12	5	2.5
		b	12	12	5	2.5

a = Without magnetic blowouts    b = With magnetic blowouts

### CASE

2M28 draw out case

### INSULATION WITHSTAND

In accordance with IEC 255-5:

2KV RMS between input and frame, output and frame, and output and input. 1.2/50 5KV impulse between each terminal and earth, between circuits not normally connected together and between terminals of the same circuit.

### NOISE IMMUNITY

Withstands the high frequency interference test detailed in IEC 255-22-1.

### AMBIENT OPERATING TEMPERATURE RANGE

-5 to 55 degrees Celsius

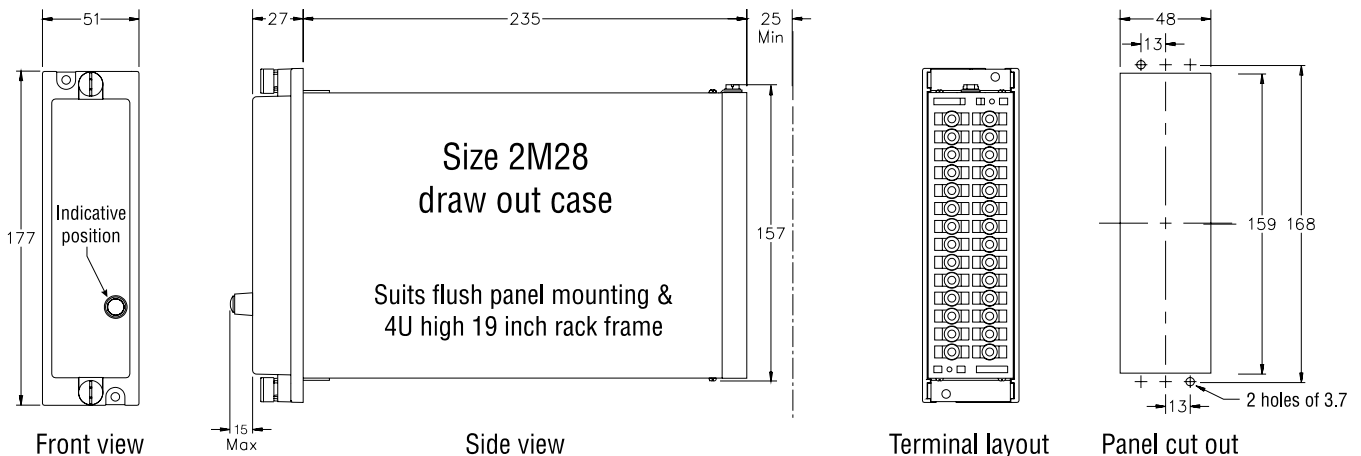

# Ordering Information

Generate the required ordering code as follows: e.g. 2P49 ABAB

**2P49** 1 2 3 4

**1 SENSING SUPPLY** - 3 Phase 3 or 4 wire (3 wire connection)

- A 110V 50Hz
- B 415V 50Hz
- C 440V 50Hz
- D 110V 60Hz
- E 415V 60Hz
- F 440V 60Hz

**2 TIME DELAY** (2s approx.)

- A Required  
Recommended for voltage selection schemes.
- B Not required

**3 OUTPUT CONTACTS**

- A Idec RH type output relay 2 C/O contacts
- B Heavy duty 6R output relay 4 C/O contacts  
Required for voltage selection schemes.
- C 6R output relay with magnetic blowouts 4 C/O contacts

**4 FLAG** – Only available with 6R output relay

- A Required – hand reset
- B Not required
- C Required – self reset

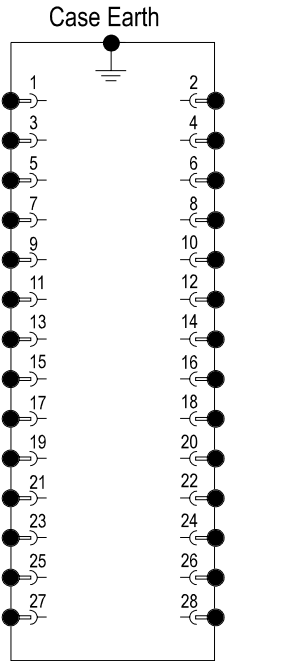

2M28 Case terminations (REAR VIEW)

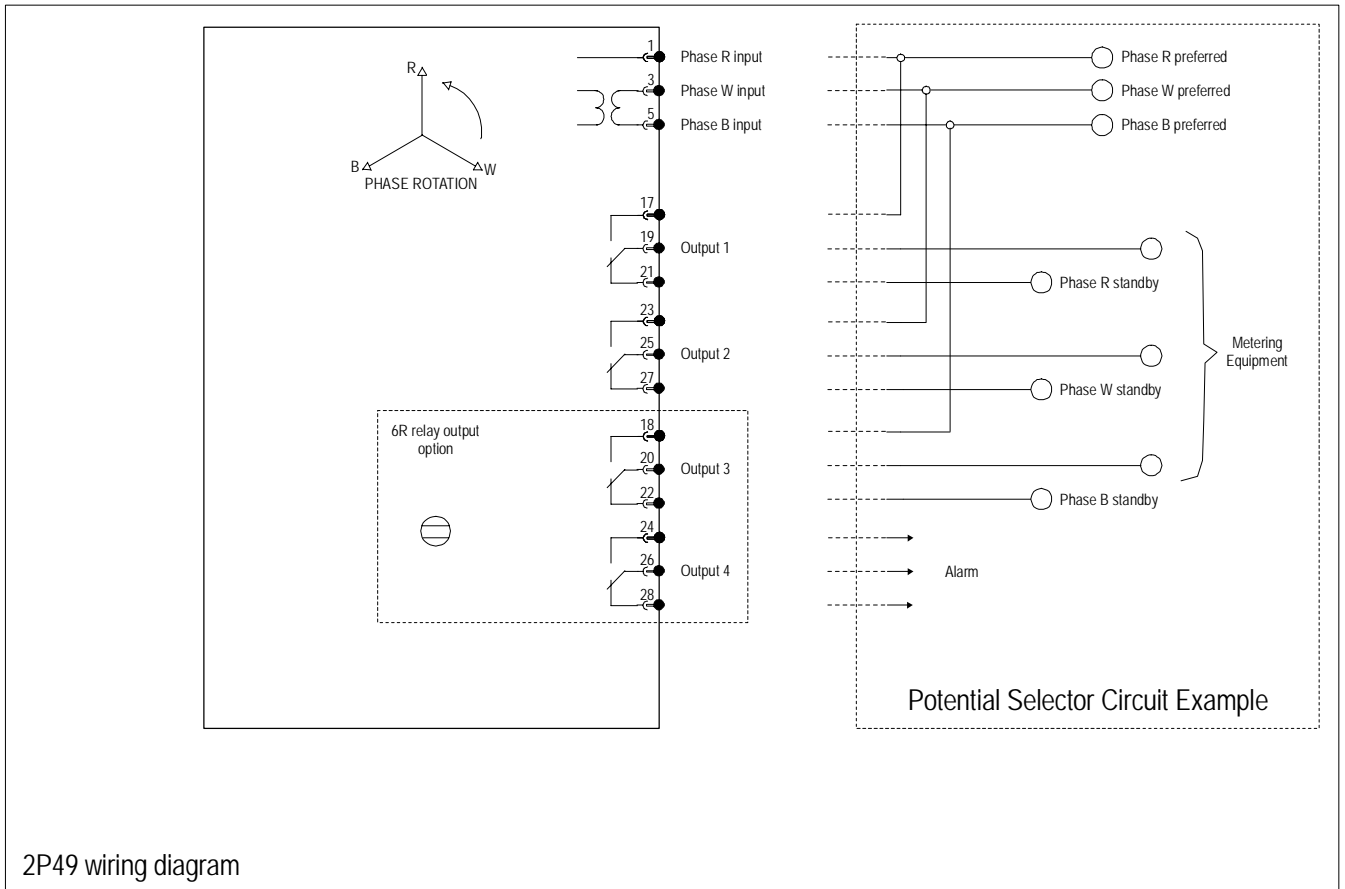

2P49 wiring diagram

## **Australian Content**

Unless otherwise stated the product(s) quoted are manufactured by RMS at our production facility in Melbourne Australia. Approximately 60% of our sales volume is derived from equipment manufactured in house with a local content close to 90%. Imported components such as semi-conductors are sourced from local suppliers & preference is given for reasonable stock holding to support our build requirements.

## **Quality Assurance**

RMS holds NCSI (NATA Certification Services International), registration number 6869 for the certification of a quality assurance system to AS/NZS ISO9001-2000. Quality plans for all products involve 100% inspection and testing carried out before despatch. Further details on specific test plans, quality policy & procedures may be found in section A4 of the RMS product catalogue.

## **Product Packaging**

Protection relays are supplied in secure individual packing cardboard boxes with moulded styrene inserts suitable for recycling. Each product & packing box is labeled with the product part number, customer name & order details.

## **Design References**

The products & components produced by RMS are based on many years of field experience since Relays Pty Ltd was formed in 1955. A large population of equipment is in service throughout Australia, New Zealand, South Africa & South East Asia attesting to this fact. Specific product & customer reference sites may be provided on application.

## **Product Warranty**

All utility grade protection & auxiliary relay products, unless otherwise stated, are warranted for a period of 24 months from shipment for materials & labour on a return to factory basis. Repair of products damaged through poor application or circumstances outside the product ratings will be carried out at the customer's expense.

## **Standard Conditions of Sale**

Unless otherwise agreed RMS Standard Terms & Conditions (QF 907) shall apply to all sales. These are available on request or from our web site.



## **Relay Monitoring Systems Pty Ltd**

6 Anzed Court, Mulgrave, Victoria 3170, AUSTRALIA

Tel: 61 3 9561 0266 Fax: 61 3 9561 0277 Email: [rms@rmspl.com.au](mailto:rms@rmspl.com.au) Web: [www.rmspl.com.au](http://www.rmspl.com.au)