

Features

- Four independent high speed arc fault tripping zones
- 1 or 2 arc fault sensors per zone allowing up to 8 arc fault sensors per 1S26 module
- Blocking status input for each arc fault zone
- Trip indication LED for each arc fault zone
- Continuous arc sensor supervision with sensor fail LED for each zone
- Non volatile memory ensures last recorded alarm states are restored on power up
- Integrated 3 phase overcurrent check function
- 20 - 200% current setting range
- Optional 5-50% E/F input
- 1A or 5A nominal CT inputs
- Integrated CB check function
- 3 phase current check block status input
- Thirteen (13) high speed configurable tripping duty output contacts
- Zone segregated or common tripping output configuration
- Reset LED flags via front panel button or status input
- Self supervision watchdog with healthy LED & alarm contact

Application

The 1S26 Series relays provide high speed arc protection for applications on medium & high voltage BUS bars. An adjustable three pole AC current check stage is provided to ensure system security while maintaining high speed clearance of arc faults.

Up to eight (8) 1S30 Arc Detectors may be connected to each 1S26 relay.

The fast overcurrent reset characteristic allows the 1S26 to be employed for the CB fail protection function on the incoming feeder to the BUS being monitored. A 2T105 relay may be employed for the CB fail time delay.

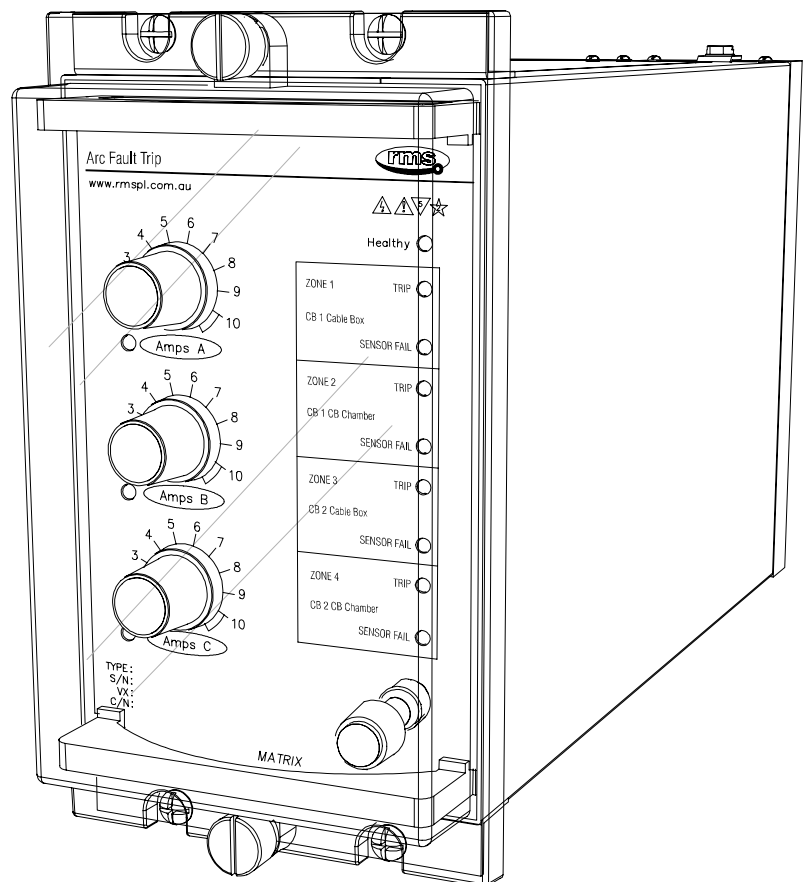

1S26 depicted in a 4M56-S draw out case with custom alarm text engraving

ARC Fault Protection

Made in Australia

Arc fault protection is a relatively new technique employed for the fast clearance of arcing faults on BUS bars & within metal clad switchgear & associated cable boxes. The arc is detected using an optical sensor & the signal input to a protection device which also monitors the load current on the system. A trip signal can be achieved in less than 10ms using arc detection only or within 15ms when using the integrated instantaneous overcurrent check. This is considerably faster than a traditional IDMT overcurrent relay & provides additional protection from the onset of arcing faults with relatively low fault currents.

BUS PROTECTION

The 1S26 Arc Fault relay is designed for application on new or existing medium voltage BUS systems with up to two incoming lines. For new installation the high speed arc protection technique offers cost advantages over traditional high impedance differential schemes. For existing installations which may not have any BUS protection or using simple earth leakage protection it is relatively simple & cost effective to retrofit an arc protection scheme as dedicated protection CT's are not required.

FEEDER PROTECTION

For the outgoing feeders arguably the greatest risk of arc fault damage exists at the CB cable termination & in the CB chamber itself due to the slow clearance times of the IDMT feeder protection. The CB cable termination is particularly at risk to ingress of moisture & rodent damage. Application of arc protection in the feeder circuits can be achieved using spare sensors & trip contacts on the 1S26 or alternatively additional 1S20 & 1S25 relays may be employed for this purpose.

ARCING FAULTS

Arcing faults can occur as a result of insulation breakdown due to equipment age & / or poor maintenance.

The degree of damage caused by arcing depends principally on the duration of the arc. If an arc lasts only 100ms, the switchgear needs to be checked & the insulation resistance measured before power can be re-established. With a 200ms arc, the power supply will be interrupted; the BUS bars & switchgear must be checked; power is re-established only after minor repairs. In the event of a 500ms arc the supply is interrupted, metal parts of the BUS chamber & switchgear are destroyed & poisonous gases are emitted. A 1s arc destroys most of the installation & may cause a fire, injury to personnel & damage to property.

BUS Bar Applications

ARC PROTECTION OF BUS BARS

Figure 1 depicts how the 1S26 may also be applied for the protection of a bus bar with two incoming lines & multiple outgoing feeders. The number of sensors in the bus chamber is dictated by the switchgear design and the length of switchboard.

In most indoor metal clad switchgear the bus bar chamber is a continuous chamber between panels only broken into segregated sections at a bus section breaker & as such the strategic placement of one or two arc sensors in each bus bar chamber run is normally adequate. The 1S30 Arc Fault sensor is available with one or two detectors per unit to allow wider coverage.

Some indoor metal clad switchgear may segregate the bus chamber of each panel from the next via insulated bus chamber side barriers per panel, if this is the case then each bus chamber per panel would need to be monitored by at least one arc sensor.

Isolating switches between BUS bar sections need also be considered & appropriate tripping zones created to ensure isolation of the faulted section.

In large enclosures the arc sensors should be placed at approximately 5m intervals. 1S30 arc sensors are also available with dual optical detectors to allow detection of arc in both directions.

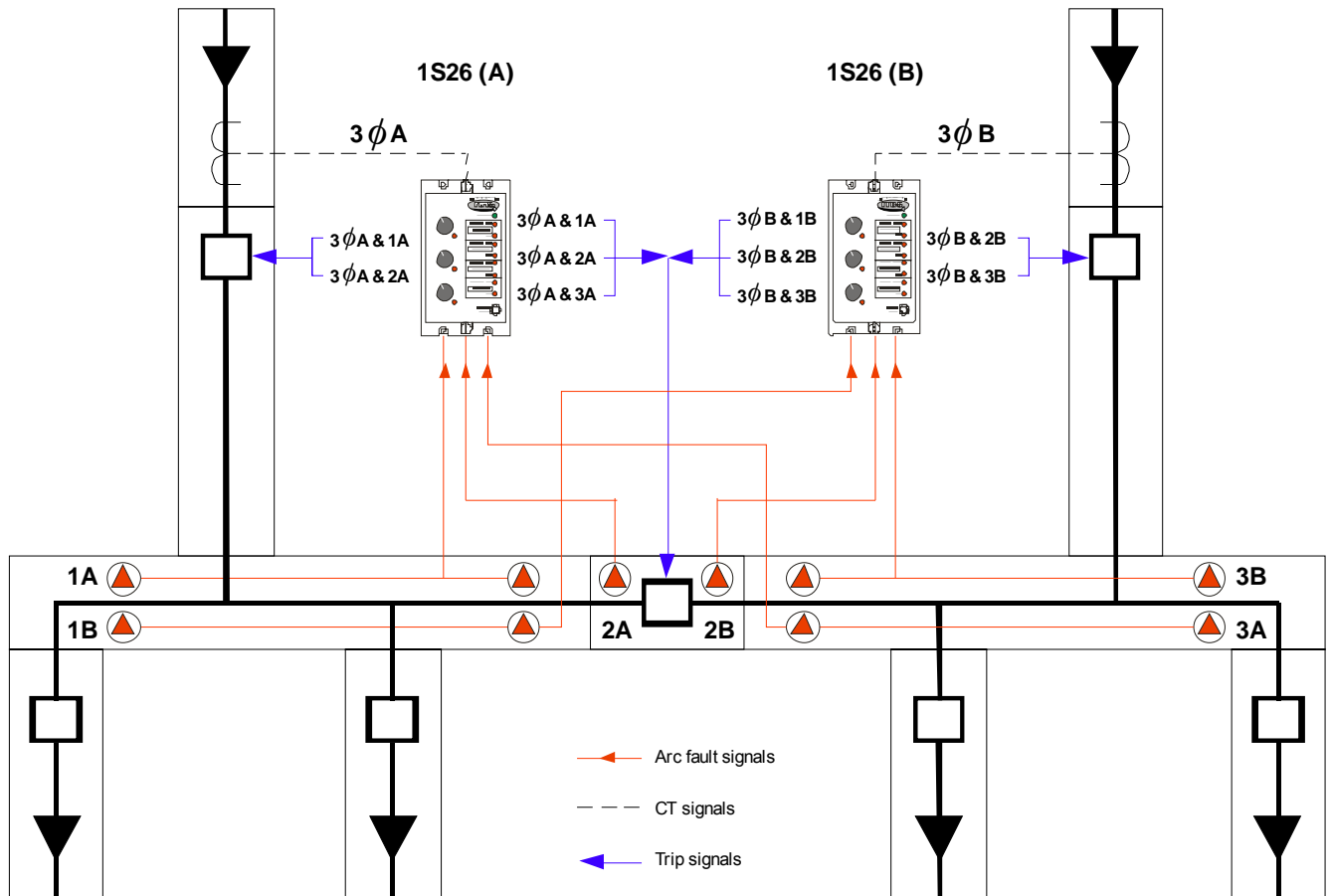

Figure 1: One to eight arc sensors located in the BUS chamber in up to four tripping zones

1S30 ARC FAULT SENSORS

Refer to the 1S30 Technical Bulletin for details.



Figure 2: 1S30 Arc Fault Sensors
Through panel mounting detector version depicted at left
Front panel view of dual detector version depicted at right

ARC FAULT ELEMENT OPERATE TIME

The arc fault optical detection element is guaranteed to pick up in less than 5ms. Where arc fault only tripping is required the 1S20 or 1S25 arc fault monitoring relays should be employed. These relays provide a trip output contact operate time of less than 10ms.

OPERATION INDICATOR

Two (2) LED's are provided for each tripping zone to provide the following status indications:

Trip: Flashes for 2s on detection of arc fault in zone & then solid.
Resets when front panel reset button pressed or voltage pulse applied to remote flag reset status input.

Fail: Flashes to indicate failure of 1S30 Arc Fault Sensor in zone.

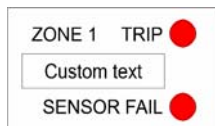

Arc Detection

ARC SENSOR FUNCTION

The 1S30 is an optical sensor that responds to the flash of light emitted during the incidence of an arcing fault. Onset of the light flash & detection by the 1S30 occurs in a few ms.

When an arc is detected, the resistance presented by the 1S30 drops to a level where the current flow increases to approximately 20mA. This increased current flow is instantaneously detected by the 1S26 & the arc trip logic picked up for that sensor zone. Refer to the 1S30 Technical Bulletin for further details.

ARC FAULT TRIPPING USING CURRENT CHECK

Fast operation of a tripping scheme usually results in reduced system security. The arc detection method can however, combine the 1S30 optical detection technique with a traditional overcurrent method to maximize system security particularly for BUS bar protection schemes. Both conditions must coexist for the trip condition to be met as depicted in figure 3.

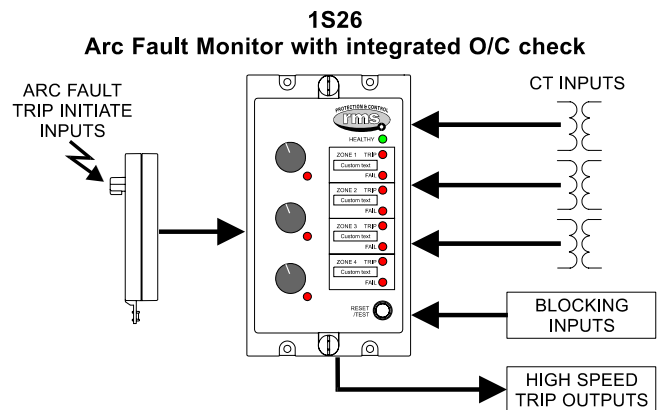

Figure 3:
Key components required to implement an Arc Fault Protection scheme with an overcurrent check stage

The application example depicted in figures 1 utilize this concept for enhanced system security in that both the 1S30 Arc Fault input AND the overcurrent must be picked up for a trip signal to be issued.

ARC DETECTION RESET TIME (Effect of multiple arc trips)

A delay of 2s is required to reset the 1S26 arc fault element after an initial arc sensor trip. Subsequent arc detection will cause the trip output contacts to re-operate.

ARC SENSOR CONTINUOUSLY PICKED UP

High ambient light levels may cause a 1S30 to be continuously picked up. This condition could occur for example if the CB cable box cover was left open in very high ambient light level conditions.

Damage to the 1S30 cable may cause the two internal wires to be shorted which would be interpreted by the 1S26 as an arc fault pick up.

If under either of the above conditions an over-current pick up occurred the 1S26 would output an arc fault trip operation.

To avoid possible mal operation due to this condition, the 1S26 is designed to automatically disable the arc fault tripping function if the 1S30 sensor is picked up for >10s.

The 1S26 alarm contact will be set & the front panel 'Sensor fail' LED will flash until the ambient light level problem is corrected to that arc fault zone. The 1S26 will then perform an arc sensor test function & automatically reset.

ARC SENSOR CIRCUIT SUPERVISION

The 1S30 Arc Sensor is the heart of the arc detection system & supervision of circuit continuity is critical for correct operation. To monitor the integrity of the wiring between the 1S30 arc sensor & 1S26 Arc Monitor, a continuous 2mA supervision current flows between the units. The 1S26 alarm contact will drop out after a 1s time delay if it fails to detect this current.

The failed zone will be indicated by the front panel 'Sensor fail' LED.

OPERATING LOGIC CONFIGURATION

Output trip contacts 1-9 will only operate if an overcurrent condition is coincident with an arc fault condition. This is known as Arc Fault & Overcurrent operating logic as depicted in figures 4 & 5.

Output contacts 10-13 may be configured to operate as per contacts 1-9 or alternatively based only on the overcurrent element for application in a CB failure scheme. This is known as overcurrent only operating logic & is depicted in figures 6 & 7.

ARC ZONE BLOCKING INPUTS

Each arc fault zone input is qualified by an independent blocking status input.

OVERCURRENT BLOCKING INPUT

The overcurrent elements are qualified by a common blocking status input.

ARC FAULT & OVERCURRENT OPERATING LOGIC

The arc pick up logic signal is maintained for a period of 2s from the instant an arc is detected. The overcurrent pick up logic has an instantaneous (<15ms) reset characteristic.

Zone segregated tripping outputs

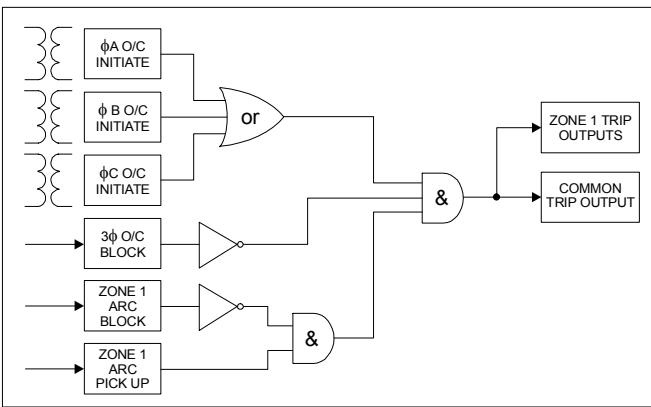

Figure 4:

Overcurrent on any phase & Arc Fault will trip contacts specified for that zone + the common arc fault contact. Logic is repeated for each arc fault zone. Configuration switch C1 set to ON Configuration switch C2 set to ON

Any Arc Fault Zone tripping outputs

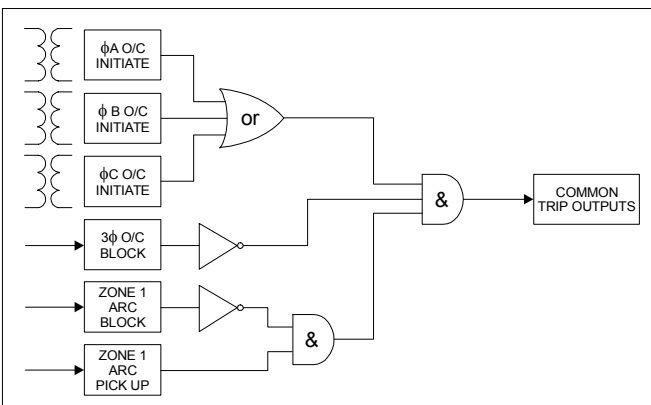

Figure 5:

Overcurrent on any phase & Arc Fault on any zone will trip all contacts. Logic is repeated for each arc fault zone. Configuration switch C1 set to ON Configuration switch C2 set to OFF

Operating Logic

OVERCURRENT ONLY OPERATING LOGIC – CB Fail

3 Phase tripping outputs

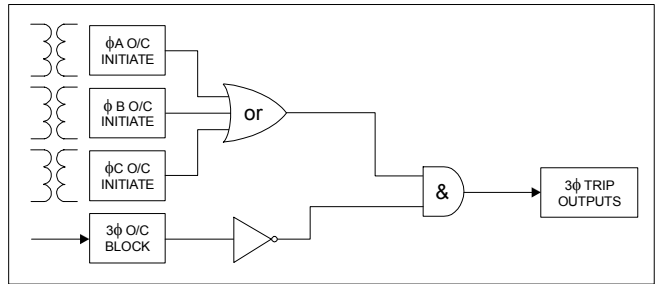

Figure 6:

Overcurrent on any phase will trip contacts 10-13. Configuration switch C1 set to OFF Configuration switch C2 set to OFF

Phase segregated tripping outputs

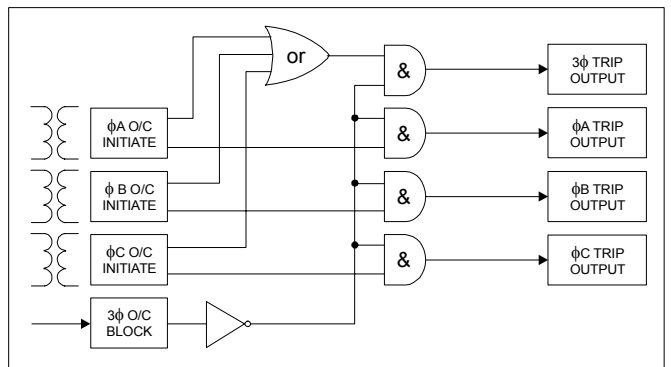

Figure 7:

Overcurrent on phase A will trip contact 10
Overcurrent on phase B will trip contact 11
Overcurrent on phase C will trip contact 12
Overcurrent on any phase will trip all contact 13
Configuration switch C1 set to OFF
Configuration switch C2 set to ON

CURRENT SETTING RANGE

Setting: Continuously adjustable control per phase of nominal CT rating
 20-200%
 5-50% Optional earth fault input (Refer figure 11)
 Repeatability: ± 2% of setting
 Accuracy: ± 5% of maximum setting

DROPOUT PICKUP RATIO OF OVERCURRENT ELEMENT

85% setting: PCB jumper J103 fitted left – Factory default
 75% setting: PCB jumper J103 fitted right as per figure 8.

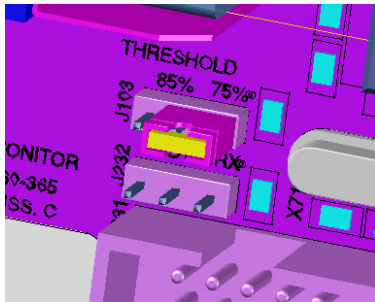

Figure 8:

To change the dropout / pickup ratio remove the relay module from the case, locate the three pin jumper header position J103 & fit jumper for 75% or 85% dropout pickup ratio.

OPERATING TIME OF CURRENT ELEMENT

At 2 X O/C setting: Logic pick up time less than 10ms
 Trip contacts configured for instantaneous overcurrent only operation will pick up in less than 15ms.

Reset time: Logic drop out time less than 15ms
 Trip contacts configured for instantaneous overcurrent only operation will reset in less than 15ms when current drops from 2 X O/C setting to zero.

OPERATING TIME OF ARC FAULT DETECTION

Arc fault element: Logic pick up time less than 5ms
 Reset time: 2s

OPERATING TIME OF O/C & ARC FAULT ELEMENTS

At 2 X O/C setting: Trip contacts pick up in less than 15ms

FRONT PANEL LED'S

System supervision: One green 'Healthy' LED
 Overcurrent pick up: One red LED per phase - self reset
 Arc trip pick up: One red LED per zone latching
 Off, flashing or on solid - latching
 Sensor fail alarm: One red LED per zone
 Off, flashing or solid - latching

Configuration & Setting

CONFIGURATION SWITCHES

Three banks of configuration switches (A, B & C), each with four (4) independent piano type switches are accessible to the user by first withdrawing the relay module from the outer case.

BANK	Switch 1	ON		OFF
A	Switch 2	ON		OFF
	Switch 3	ON		OFF
	Switch 4	ON		OFF

CONFIGURATION SWITCH SETTING SUMMARY

The internal wiring label identifies the position of the following switch functions as follows:

Switch	ON	OFF
A1	Zone 1 Arc sensor fitted	Zone 1 Arc sensor not fitted
A2	Zone 2 Arc sensor fitted	Zone 2 Arc sensor not fitted
A3	Zone 3 Arc sensor fitted	Zone 3 Arc sensor not fitted
A4	Zone 4 Arc sensor fitted	Zone 4 Arc sensor not fitted

Switch	ON	OFF
B1	Zone 1 – 2 Arc sensors	Zone 1 – 1 Arc sensor
B2	Zone 2 – 2 Arc sensors	Zone 2 – 1 Arc sensor
B3	Zone 3 – 2 Arc sensors	Zone 3 – 1 Arc sensor
B4	Zone 4 – 2 Arc sensors	Zone 4 – 1 Arc sensor

Switch	ON	OFF
C1	Output contacts 10-13 Arc & Overcurrent logic	Output contacts 10-13 Overcurrent only logic
C2	Zone & Phase segregated outputs	Any zone & 3 Phase outputs
C3	Apply volts to BLOCK	Remove volts to BLOCK
C4	DC only status inputs	AC/DC status inputs

Table 1

OUTPUT RELAY FUNCTION CONFIGURATION

The function of the output contacts is dependent on the position of configuration switches C1 & C2 as per Table 2. Refer operating logic section for detailed functional description.

Relay	Configuration Switch Positions				
	C1 ON		C1 OFF		
	C2 ON	C2 OFF	C2 ON	C2 OFF	
1	Zone 1 Arc AND any Ø O/C	Any Arc Fault Zone AND any Ø O/C	Zone 1 Arc AND any Ø O/C	Any Arc Fault Zone AND any O/C Phase	
2	Zone 2 Arc AND any Ø O/C		Zone 2 Arc & any Ø O/C		
3	Zone 3 Arc AND any Ø O/C		Zone 3 Arc AND any Ø O/C		
4	Zone 4 Arc AND any Ø O/C		Zone 4 Arc AND any Ø O/C		
5	Any zone Arc AND any Ø O/C		Any zone Arc AND any Ø O/C		
6	Zone 1 Arc AND any Ø O/C		ØA		Any O/C Phase
7	Zone 2 Arc AND any Ø O/C		ØB		
8	Zone 3 Arc AND any Ø O/C		ØC		
9	Zone 4 Arc AND any Ø O/C		3Ø		

Table 2



Technical Data

AUXILIARY SUPPLY

A high efficiency switchmode power supply is incorporated which provides a low burden to the auxiliary supply.

Low range model: 20-70V DC
High range model: 40-300V DC & 40-275V AC

BURDENS

Quiescent: Less than 4W at 110V DC
Maximum: Less than 10W
Sensing circuits: VA per phase all settings at 50Hz.

I amps	1A CT input	5A CT input
1	0.25	<0.01
5	6.3	0.18
10	25	0.72
20	100	2.9
25	-	4.5
30	-	6.5

CT INPUT THERMAL WITHSTAND (Per phase)

	1A CT	5A CT *
Continuous	3.5	25
4.5s	39	250
3s	75	450
2s	90	550
1s	120	800
0.5s	180	1,000

* M Series case terminals are limited to 400A for 1s.

ARC FAULT BLOCK STATUS INPUT DELAY

Initiate input	Minimum	AC Rejection Filter	
		ON	OFF
DC	P/U	<16ms	<4ms
	D/O	<4ms	<16ms
AC	P/U	N/A	<23ms
	D/O		<33ms

STATUS INPUT OPERATING VOLTAGE

An internal configuration switch is provided to select status input operation for DC only or AC/DC. This setting may be pre defined when ordering. The status inputs are non polarized.

18 - 300V DC Set Configuration Switch to **ON**
In this mode the universal status input will reject AC signals that may be induced on the control wiring. Suitable for high security applications where a DC battery supply is available.

18 - 300V DC & 18 - 275V AC Set Configuration Switch to **OFF**
In this mode the universal status input is designed to operate on both AC & DC input voltages. Suitable for applications where an AC auxiliary voltage is available such as transformer or generator control panels.

STATUS INPUT MINIMUM OPERATING CURRENT

10mA P/U for 1ms then reducing to 1.5mA after 4ms.

RESET

Press the front reset button or pulse the reset status input.

OUTPUT CONTACTS

Refer logic diagrams & tables 1 & 2 for function configuration.

Arc & O/C: 4 x 2 N/O contacts
Common O/C & Arc: 1 N/O
O/C only or O/C & Arc: 4 x 1 C/O contacts
Fail alarm: 1 C/O contact for the power supply / CPU fail / arc fault sensor.
Normally picked up & drops out to signal an alarm condition.

OUTPUT CONTACT RATINGS

IEC60255-0-2

Carry continuously 5A AC or DC
Make & carry 0.5s 20A AC or DC
L/R ≤ 40ms & V ≤ 300V 0.2s 30A AC or DC
AC resistive 1,250VA
Break capacity AC inductive 250VA @ PF ≤ 0.4
I ≤ 5A & V ≤ 300V DC resistive 75W
DC inductive 30W @ L/R ≤ 40ms
50W @ L/R ≤ 10ms
Minimum number of operations 10⁶ at maximum load
Minimum recommended load 0.5W limit 10mA / 5V

TRANSIENT OVERVOLTAGE

IEC60255-5

Between all terminals & earth 5kV 1.2/50us 0.5J
Between independent circuits without damage or flashover 5kV 1.2/50us 0.5J

INSULATION COORDINATION

IEC60255-5

Between all terminals & earth 2.0kV RMS for 1 minute
Between independent circuits 2.0kV RMS for 1 minute
Across normally open contacts 1.0kV RMS for 1 minute

AUXILIARY SUPPLY

IEC60255-11

Allowable breaks / dips in supply ≤ 20ms
Collapse to zero from nominal voltage

HIGH FREQUENCY DISTURBANCE

IEC60255-22-1 CLASS III

2.5kV 1MHz common mode Arc & O/C: No mal operation
1.0kV 1MHz differential mode O/C only: ≤ 5% variation

ELECTROSTATIC DISCHARGE

IEC60255-22-2 CLASS III

6kV contact discharge Arc & O/C: No mal operation
O/C only: ≤ 5% variation

RADIO FREQUENCY INTERFERENCE

IEC60255-22-3

10V/m, 80 TO 1,000MHz Arc & O/C: No mal operation
O/C only: ≤ 5% variation

FAST TRANSIENT

IEC60255-22-4

4kV, 5/50ns, 2.5KHz repetitive Arc & O/C: No mal operation
O/C only: ≤ 5% variation

CONDUCTED RFI

IEC60255-22-6

10V, 0.15 to 80MHz Arc & O/C: No mal operation
O/C only: ≤ 5% variation

TEMPERATURE RANGE

Operating: -5 to +55°C
Storage: -25 to +75°C

HUMIDITY

IEC68-2-1/2

40°C & 95% RH non condensing



Visit www.rmspl.com.au for the latest product information.

Due to RMS continuous product improvement policy this information is subject to change without notice. 1S26/Issue G/07/03/07 - 6/10

TERMINATION SCREWS

M4 Screws

An M4 screw kit is supplied as standard with each 1S26. Additional M4 screw kits may be purchased separately.

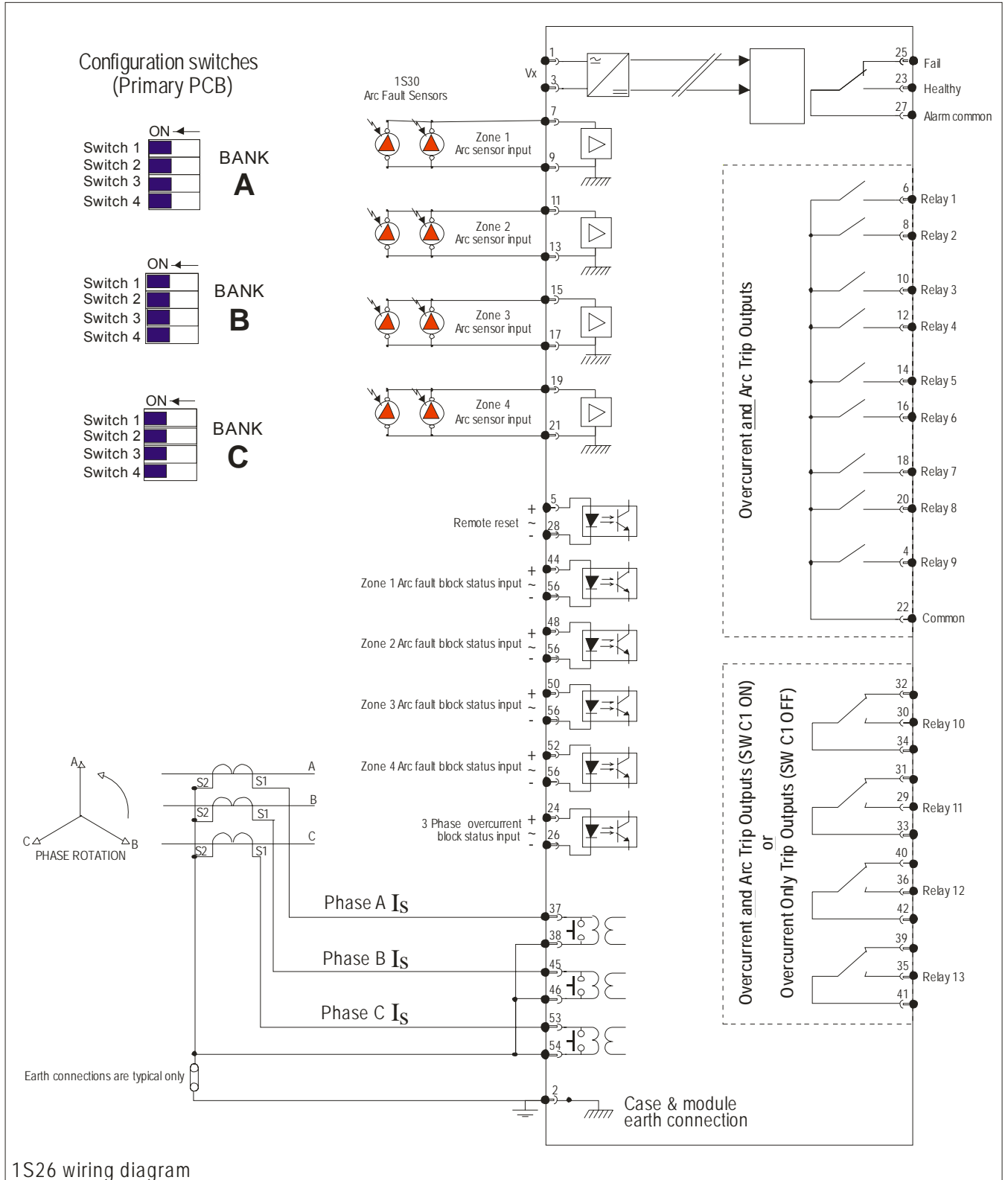

Figure 9: Wiring diagram for 1S26 four zone arc fault monitor - Relays shown in de-energized condition
 Refer to figure 11 for two phase overcurrent + E/F configuration

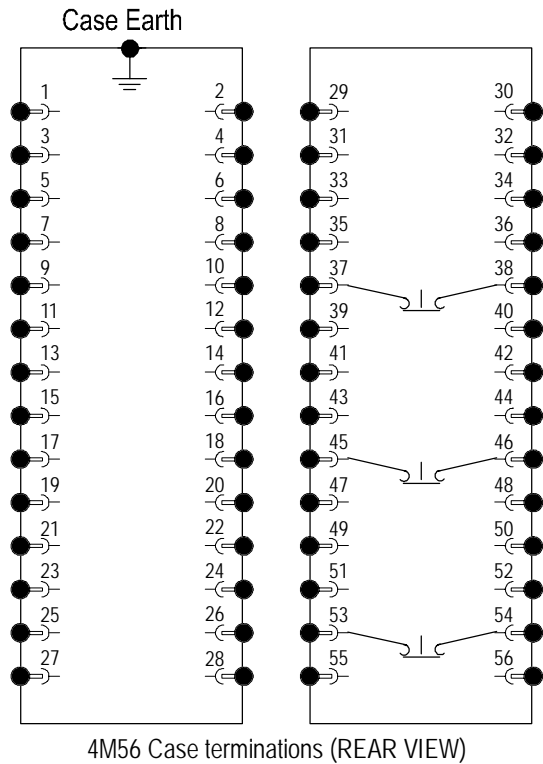

Figure 10

Case Mounting

CASE
4M56-S draw out case

ACCESSORIES SUPPLIED WITH EACH RELAY
1 x M4 self threading mounting screw kit P/N 290-406-151
2 x M4 terminal screw kit (28 per kit) P/N 290-407-153

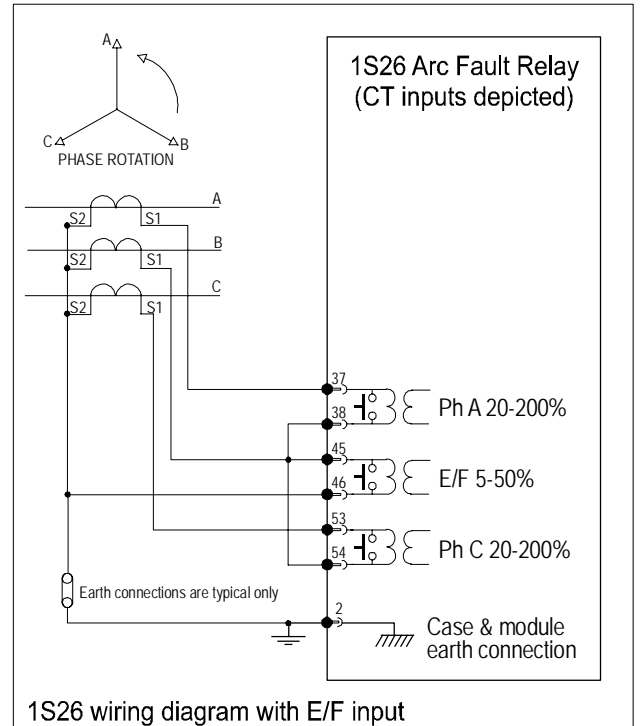

Figure 11: CT wiring configuration when using earth fault input

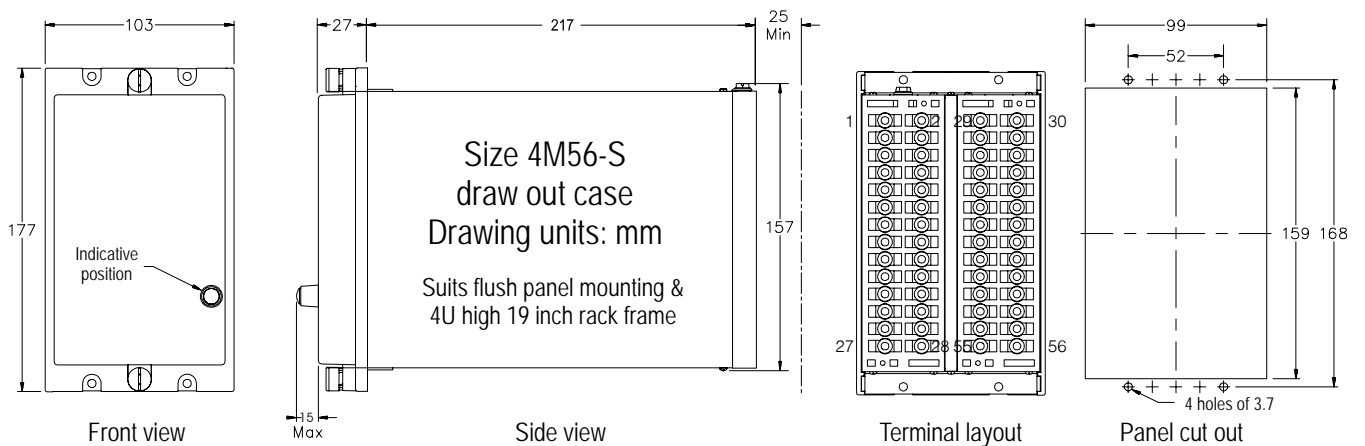

Figure 12: Case mounting details

ALARM TEXT LABELS

The 1S26 front panel has provision for custom text to identify the sensor location for each arc fault tripping zone. The required text may be engraved on the front panel by the factory if specified at time of order. Alternatively the front panel may be removed for engraving by the user or contractor. The RMS web site provides an ACAD file for this purpose.

The front panel is fabricated from flexible plastic sheet with a white surface & black substrate to provide high contrast black text when engraved.

Removal of the front label is achieved by drawing out the 1S26 module from the outer case & pulling the label from the edges at the mid point between the top & bottom draw out handles. This will cause the label to bend & disengage from the top & bottom handle retention points. Once free from the 1S26 module the front label can be placed on an engraving table. Additional factory engraved labels may be sourced from RMS for later field installation.

While an engraved label provides the most permanent record other methods such as laser printed stick on labels or indelible marker pen may be satisfactorily employed.

CUSTOM ENGRAVED TEXT DEFINITION

Complete the following tables with one character per box. Refer to the front panel layout depicted in figure 13. Submit completed labeling information with the 1S26 product ordering code.

Maximum characters: 2 lines x 15 characters / tripping zone.
Maximum font size: 1 line x 10 characters / tripping zone.

Custom text will be left justified.

Zone 1

Zone 2

Zone 3

Zone 4

Ordering Information

ORDER CODE

The order code determines the production build in the factory & cannot be changed in the field.

Generate the required order code as follows: e.g. 1S26 BAAA

General Type	Order Code			
	1	2	3	4
1S26	-			

1 AUXILIARY SUPPLY RANGE

- A 20 - 70V DC
- B 40 - 300V DC & 40 - 275V AC

2 CURRENT SETTING (% of nominal)

- A 20-200% all phases
- B 20-200% phase A & C + 5-50% E/F (In place of phase B)

3 CT RATING (Nominal)

- A 1A
- B 5A

4 CUSTOM ENGRAVED TEXT

- A Not required No engraving - factory default
- B Required Complete the custom text details at left

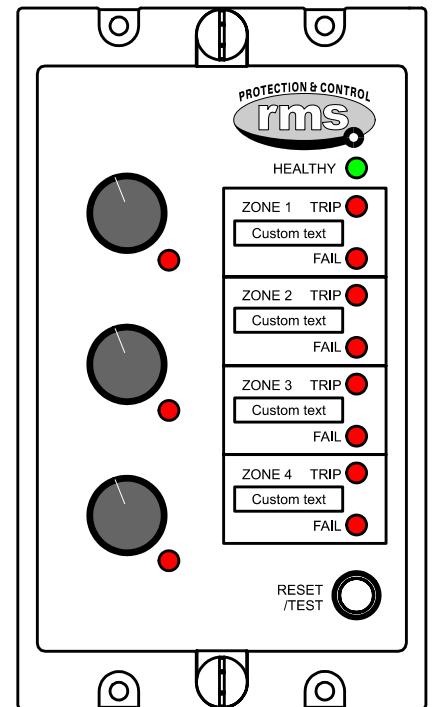

Figure 13: Alarm text position layout

CONFIGURATION CODE (Optional specification)
 Refer to the wiring diagram for each 1S26 model for details on configuration switch setting.

The configuration code can be set in the field by withdrawing the relay module & following the instructions on the side plate label for setting the configuration switches.

The configuration code may be specified at time of order so that the relay will be shipped from the factory pre-set to meet customer pre-determined operating requirements.

e.g. CONFIG A - 0101

If a configuration code is not specified the factory default will be set as indicated below:

- CONFIG A - 1111
- CONFIG B - 1111
- CONFIG C - 1111

Factory Configuration

Specify Factory Configuration	-	Configuration Switches			
CONFIG A		A1	A2	A3	A4

- A1-4 ZONE 1 - 4 SENSOR INPUTS**
- 1 ON Arc sensor(s) connected (Default)
 - 0 OFF No sensor connected

Specify Factory Configuration	-	Configuration Switches			
CONFIG B		B1	B2	B3	B4

- B1-4 ZONE 1 - 4 SECOND SENSOR**
- 1 ON Second sensor connected (Default)
 - 0 OFF Single sensor only

Specify Factory Configuration	-	Configuration Switches			
CONFIG C		C1	C2	C3	C4

- C1 OUTPUT CONTACTS FUNCTION**
- 1 ON Output contacts 10-13 Arc & O/C logic (Default)
 - 0 OFF Output contacts 10-13 O/C only logic

- C2 OUTPUT CONTACTS GROUPING**
- 1 ON Zone & phase segregated output tripping (Default)
 - 0 OFF Any arc zone & 3 phase output tripping

- C3 ARC FAULT INITIATE INPUT FUNCTION**
- 1 ON Apply volts to BLOCK arc detection (Default)
 - 0 OFF Remove volts to BLOCK arc detection

- C4 STATUS INPUT AC REJECTION**
- 1 ON DC operation only - AC rejection ON (Default)
 - 0 OFF AC / DC operation - AC rejection OFF

Australian Content

Unless otherwise stated the product(s) quoted are manufactured by RMS at our production facility in Melbourne Australia. Approximately 60% of our sales volume is derived from equipment manufactured in house with a local content close to 90%. Imported components such as semi-conductors are sourced from local suppliers & preference is given for reasonable stock holding to support our build requirements.

Quality Assurance

RMS holds NCSI (NATA Certification Services International), registration number 6869 for the certification of a quality assurance system to AS/NZS ISO9001-2000. Quality plans for all products involve 100% inspection and testing carried out before despatch. Further details on specific test plans, quality policy & procedures may be found in section A4 of the RMS product catalogue.

Product Packaging

Protection relays are supplied in secure individual packing cardboard boxes with moulded styrene inserts suitable for recycling. Each product & packing box is labeled with the product part number, customer name & order details.

Design References

The products & components produced by RMS are based on many years of field experience since Relays Pty Ltd was formed in 1955. A large population of equipment is in service throughout Australia, New Zealand, South Africa & South East Asia attesting to this fact. Specific product & customer reference sites may be provided on application.

Product Warranty

All utility grade protection & auxiliary relay products, unless otherwise stated, are warranted for a period of 24 months from shipment for materials & labour on a return to factory basis. Repair of products damaged through poor application or circumstances outside the product ratings will be carried out at the customer's expense.

Standard Conditions of Sale

Unless otherwise agreed RMS Standard Terms & Conditions (QF 907) shall apply to all sales. These are available on request or from our web site.



Relay Monitoring Systems Pty Ltd

6 Anzed Court, Mulgrave, Victoria 3170, AUSTRALIA

Tel: 61 3 9561 0266 Fax: 61 3 9561 0277 Email: rms@rmspl.com.au Web: www.rmspl.com.au