



Reyrolle
Protection
Devices

7SG17-Rho 3

Multifunction Protection Relays

Answers for energy

SIEMENS

Contents

Technical Manual Chapters

1. Description of Operation
2. Performance Specification
3. Relay Settings
4. Communications Interface
5. Applications Guide
6. Installation Guide
7. Commissioning and Maintenance
8. Maintenance
9. Diagrams
10. Addendum

The copyright and other intellectual property rights in this document, and in any model or article produced from it (and including any registered or unregistered design rights) are the property of Siemens Protection Devices Limited. No part of this document shall be reproduced or modified or stored in another form, in any data retrieval system, without the permission of Siemens Protection Devices Limited, nor shall any model or article be reproduced from this document unless Siemens Protection Devices Limited consent.

While the information and guidance given in this document is believed to be correct, no liability shall be accepted for any loss or damage caused by any error or omission, whether such error or omission is the result of negligence or any other cause. Any and all such liability is disclaimed.

7SG17 Rho 3

Multifunction Protection Relays

Document Release History

This document is issue 2010/02. The list of revisions up to and including this issue is:

Pre release

2010/02	Document reformat due to rebrand

Software Revision History

--	--	--

The copyright and other intellectual property rights in this document, and in any model or article produced from it (and including any registered or unregistered design rights) are the property of Siemens Protection Devices Limited. No part of this document shall be reproduced or modified or stored in another form, in any data retrieval system, without the permission of Siemens Protection Devices Limited, nor shall any model or article be reproduced from this document unless Siemens Protection Devices Limited consent.

While the information and guidance given in this document is believed to be correct, no liability shall be accepted for any loss or damage caused by any error or omission, whether such error or omission is the result of negligence or any other cause. Any and all such liability is disclaimed.

Contents

1.	INTRODUCTION.....	3
2.	FUNCTIONS	3
2.1	Thermal overload protection.....	3
2.1.1	Equivalent thermal current.....	4
2.1.2	Thermal model	4
2.1.3	Hot/cold ratio	5
2.1.4	Thermal capacity alarm level.....	5
2.1.5	Overload alarm level.....	5
2.1.6	Load increase alarm level.....	5
2.1.7	Thermal restart inhibit level	6
2.2	Stall and locked rotor protection	6
2.2.1	Start time less than locked rotor withstand time	6
2.2.2	Start time greater than locked rotor withstand time	7
2.3	Overcurrent protection for Phase Short Circuits.....	8
2.4	Earth fault protection	8
2.5	Phase unbalance protection.....	8
2.5.1	Phase difference protection.....	8
2.5.2	Negative sequence overcurrent protection	9
2.6	Undercurrent protection.....	9
2.7	Number of starts protection	10
2.8	Optional temperature inputs.....	10
2.8.1	RTD inputs	10
2.8.2	Thermistor inputs.....	10
2.8.3	Detector failure protection	10
2.8.4	Detector gating	10
2.9	Output contacts	10
2.10	Status inputs	11
2.11	Circuit breaker fail protection.....	11
2.12	Trip circuit supervision.....	11
2.13	Multiple settings group	11
3.0	OTHER FEATURES	12
3.1	Indications and displays	12
3.2	Circuit breaker maintenance	12
3.3	Standard displays.....	12
3.4	Phase sequence and phase difference ammeters	12
3.5	Motor status	12
3.6	Time to trip	13
3.7	Time to start	13
3.8	Thermal capacity used	13
3.9	Start counter.....	13
3.10	Last starting time	13
3.11	Last starting current	13
3.12	Motor running time	13
3.13	Cumulative motor run time hours	13
3.14	Maximum demand.....	13
3.15	External trip/emergency stop.....	14
3.16	Temperature inputs	14
3.17	Default display setting and general alarms.....	14
4	DATA RECORDS	15
4.1	Fault records	15
4.2	Event records	15
4.3	Communications	16
4.4	Self monitoring	16
4.5	Password feature	16
5	USER INTERFACE.....	17
5.1	General arrangement	17
5.2	Liquid crystal display	17
5.3	LED indications	17
5.4	Keypad.....	17
6	SETTINGS AND DISPLAYS	18
7	RELAY HARDWARE	20
7.1	Internal construction.....	20
7.2	Front cover.....	20
7.3	Terminal blocks	20

1. INTRODUCTION

The 7SG17 is a multi-function numerical Motor Protection relay suitable for all types of a.c. induction motors up to the highest ratings available. Whilst medium voltage 3-phase motors are very reliable and robust, modern designs operate much closer to their thermal limits and to give adequate protection sophisticated protection relays are required. In addition, increased industrial use of power electronics leads to corruption of power systems and unless specific equipment is installed to eliminate the corruption it can cause considerable rotor overheating. The relay has been designed to protect the motor against these phenomena as well as known abuses such as mechanical overload, stalling, single phasing, terminal box and cabling failures, and too frequent starts. The relay can be set to accurately mimic both the heating and cooling characteristics of the protected motor and consequently ensure that the thermal withstand of the machine is not exceeded, at the same time allowing full use of the motor's thermal capability.

2. FUNCTIONS

2.1 Thermal overload protection

The main protection characteristic of the Rho range conforms to IEC60255-8 (Thermal Electrical Relays) which defines a 'cold' operating characteristic of:

$$t = \tau \cdot \text{Ln} \frac{I^2}{I^2 - (k \cdot I_B)^2}$$

Where:

t = operating time (minutes)

τ = time constant (τ_h for 7SG17)

I = relay current

I_B = basic current

k = constant

Basic current I_B is equivalent to the full load current of the protected motor. Constant k is a multiplying factor resulting in the thermal overload setting of the relay I_θ (i.e. $I_\theta = k \cdot I_B$)

If a protected motor has been running for a period of time then the IEC60255-8 'hot' operating characteristic becomes applicable for calculation of relay operating time:

$$t = \tau \cdot \text{Ln} \frac{I^2 - I_P^2}{I^2 - (k \cdot I_B)^2}$$

Where:

I_P = steady state relay current prior to the overload

Note that there are actually an infinite number of operating curves for different values of load current from the cold state to full load.

2.1.1 Equivalent thermal current

Positive and negative phase sequence components are calculated from the three phase current inputs. These are then used to generate an equivalent thermal current I_{eq} which takes the place of the relay current in the IEC60255-8 operating characteristics. The equivalent current is defined as follows:

$$I_{eq} = \sqrt{I_1^2 + KI_2^2}$$

Where:

I_1 = Positive Phase Sequence Current (PPS)

I_2 = Negative Phase Sequence Current (NPS)

K = NPS Weighting Factor

The user selectable value K is a weighting factor allowing for the greater heating effect on the rotor of the negative phase sequence (NPS) component of an unbalanced three phase supply. If K is set to zero by the user, then the thermal protection uses the average of the three RMS phase currents in place of the equivalent current. In such a configuration, no NPS biasing is applied to the thermal protection.

2.1.2 Thermal model

The relay uses the equivalent current to track the thermal state of the motor. The thermal state is expressed as a percentage of the thermal capacity of the motor and the motor is disconnected when the thermal state reaches 100% of thermal capacity. The thermal model accommodates both heating and cooling conditions with exponential curves as illustrated in figure 1.

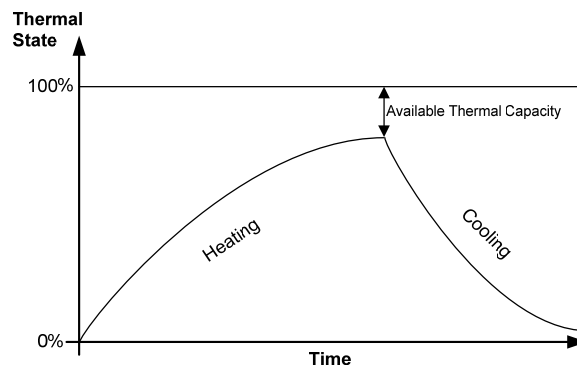

Figure 1 – Exponential heating and cooling curves

For the heating curve:

$$\theta = \frac{I_{eq}^2}{I_{\theta}^2} \left(1 - e^{-\frac{t}{\tau}} \right) \times 100\%$$

For the cooling curve:

$$\theta = \theta_F \cdot e^{-\frac{t}{\tau}} \quad \text{or} \quad t = \tau \cdot \ln \frac{\theta}{\theta_F}$$

Where:

θ = thermal state at time t

θ_F = final thermal state before disconnection of motor

I_{eq} = equivalent thermal current (see 2.1.1)

I_{θ} = thermal overload current setting (or k.IB)

τ = thermal time constant

The final steady state thermal condition can be predicted for any steady state value of input current since when $t \gg \tau$,

$$\theta_F = \frac{I_{eq}^2}{I_\theta^2} \times 100\%$$

The thermal overload setting I_θ is expressed as a fraction of the relay nominal current and is equivalent to the factor $k.l_B$ as defined in the IEC60255-8 thermal operating characteristics. It is the value of current above which 100% of thermal capacity will be reached after a period of time and it is therefore normally set slightly above the full load current of the protected motor.

Three values of thermal time constant τ are available for use during different phases of motor operation as follows:

τ_h = Thermal overload heating time constant for use during normal running and under overload conditions of current up to the motor starting current setting ISTART.

τ_s = Thermal overload heating time constant for use during motor starting and applied for current above the starting current setting ISTART.

τ_c = Cooling time constant used to take account of the reduced rate of cooling of a stopped motor and applied when current falls below the motor stopped current setting ISTOP.

2.1.3 Hot/cold ratio

The hot/cold ratio setting determines the percentage of thermal capacity available for a motor running at full load current compared to that available when the motor is cold. It modifies the IEC60255-8 hot curve as below:

$$t = \tau \cdot \text{Ln} \frac{I^2 - (1-H/C)I_p^2}{I^2 - I_\theta^2}$$

The thermal model is modified under normal load conditions (ie when $I_{eq} < I_q$) by multiplying the predicted final steady thermal state by $(1-H/C)$.

$$\theta_F = \frac{I_{eq}^2}{I_\theta^2} (1-H/C) \times 100\%$$

A setting is available to switch this feature out of service, ie H/C is then equivalent to zero and full account is taken of the prior load current.

2.1.4 Thermal capacity alarm level

The thermal capacity alarm setting is expressed as a percentage of thermal capacity. An instantaneous alarm output is given if the thermal state exceeds the setting.

2.1.5 Overload alarm level

An instantaneous alarm output is given if the equivalent thermal current I_{eq} exceeds the thermal overload setting I_q .

2.1.6 Load increase alarm level

A further alarm is available to provide warning of a sudden increase in load. The alarm level is set as a multiple of the thermal overload setting I_q .

2.1.7 Thermal restart inhibit level

The thermal restart inhibit setting is expressed as a percentage of thermal capacity. It controls an output contact to prevent the motor from being started until its thermal state has fallen below the setting. The default setting for the output contact is output relay 3, a changeover contact. Its normally closed contact can be connected in the motor starting circuit, thus breaking the circuit when the restart inhibit feature registers thermal state above setting. A thermal capacity reset command is available which resets the thermal state to zero and thus releases the thermal restart inhibit. The thermal restart inhibit setting can be set to 'OFF'.

2.2 Stall and locked rotor protection

Figure 2 illustrates the common situation where the thermal overload protection can be set to provide protection against stalling during running and the locked rotor condition on starting.

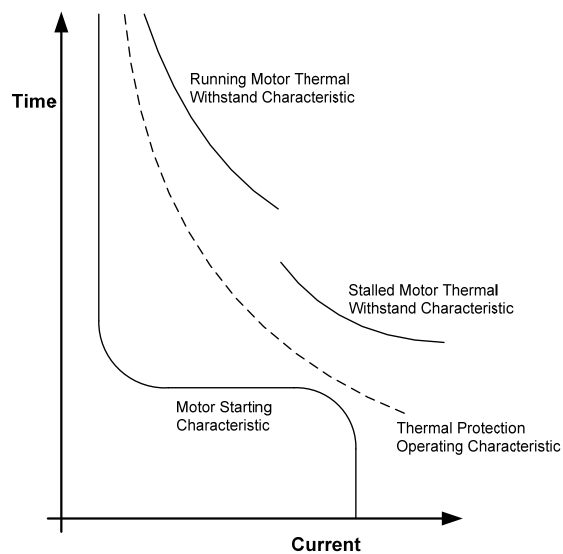

Figure 2 - Thermal protection for running, starting and stalling

In cases where the thermal characteristic does not offer sufficient protection against stalling during running or a locked rotor condition on starting, an additional protection is provided. There are two methods of applying this protection depending on whether the motor starting time is significantly less than the permissible locked rotor withstand time.

2.2.1 Start time less than locked rotor withstand time

Figure 3 illustrates the most common situation where the stalled motor condition can be effectively distinguished from a healthy start by simple current time grading. A single definite time characteristic can give protection during starting and stalling without causing mal-operation during a healthy start sequence. A trip occurs when current above the start current setting I_{START} is measured for longer than the stall withstand delay setting t_{s1} . I_{START} is set as a multiple of the thermal overload current setting I_0 and an instantaneous motor start alarm output is also provided. The stall and locked rotor protection can be disabled by setting t_{s1} to 'OFF'.

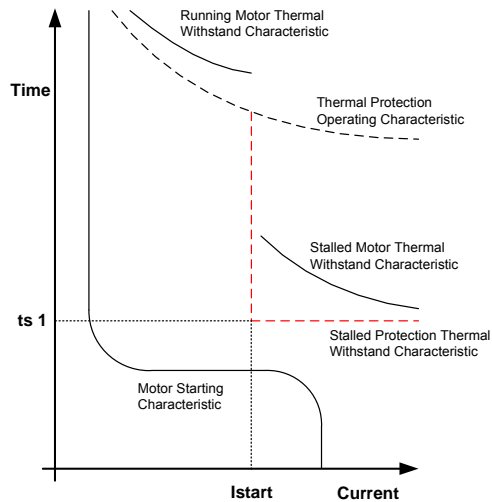

Figure 3 - Stall and locked rotor protection for start time less than withstand time

2.2.2 Start time greater than locked rotor withstand time

In cases where the motor starting time approaches or exceeds the stall withstand time then discrimination between starting and stalling cannot be so easily achieved and the two conditions cannot be protected by simple current, time grading. See figure 4

A tachometric 'zero speed' switch mounted on the rotor shaft can be used to signal that the motor is running up. A relay status input is connected to receive a voltage signal via the switch and is programmed to the 'No Accel.' function in the status configuration menu. In this mode the second stall withstand delay timer t_{s2} is used. This timer will not run unless the status input is energised. If the switch is closed, indicating a stopped motor, and current is measured above the start current setting I_{START} then the stall withstand delay timer t_{s2} begins to run. On a healthy start the switch will open, thus stopping the timer. Under stall conditions, a trip will occur after t_{s2} , which should be set with a delay less than the motor stall withstand time.

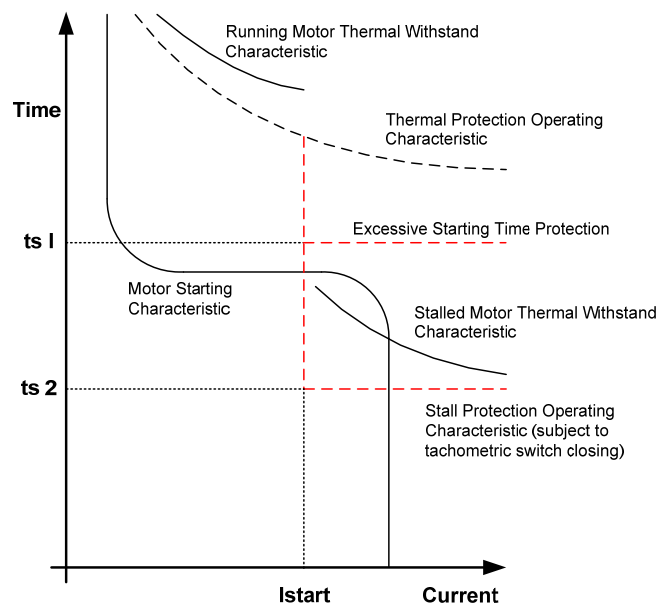

Figure 4 - Start time greater than locked rotor withstand Time

In this configuration, the first timer t_{s1} can be used to provide additional protection against the motor running up but drawing starting current for an excessive time. Timer t_{s1} runs for current above I_{START} regardless of the signal from the zero speed switch to provide excessive start time protection.

2.3 Overcurrent protection for Phase Short Circuits

A transient free high set overcurrent element measures the RMS current in each phase. The element provides alarm and trip outputs. An alarm output is given if current exceeds the high set alarm setting IHA in any phase for longer than the definite time delay tHA. A trip occurs if current exceeds the high set trip setting IHS in any phase for longer than the definite time delay tHS.

The current thresholds are set as a multiple of the relay nominal current In. The overcurrent alarm and trip features can be disabled by setting IHA and IHS to OFF.

2.4 Earth fault protection

An earth fault overcurrent element measures RMS current either from a core balance CT or in the residual circuit of the phase CTs. In the case of the residual connection method, if a low earth fault setting is applied it is advisable to use a stabilising resistor to increase the burden in the residual circuit, or to introduce a time lag.

The element provides alarm and trip outputs. An alarm output is given if current exceeds the earth fault alarm setting I_{EA} for longer than the definite time delay t_{EA}. A trip occurs if current exceeds the earth fault trip setting I_{EF} for longer than the definite time delay t_{EF}. The current thresholds are set as a multiple of the relay nominal current In. The earth fault alarm and trip features can be disabled by setting I_{EA} and I_{EF} to OFF.

An additional earth fault inhibit current setting I_{EI} is available. The earth fault trip element does not operate for currents above this setting, so preventing damage to contactors which may have a low breaking capacity.

The earth fault alarm is not affected by the inhibit feature and may be used to issue a back-trip signal to an upstream circuit breaker.

2.5 Phase unbalance protection

Separate protection is available for the conditions of phase unbalance, loss of phase and reverse phase sequence. This feature can be programmed to operate either as phase difference protection or as negative phase sequence overcurrent protection. It can also be disabled altogether.

2.5.1 Phase difference protection

If phase difference protection is selected then the relay calculates the phase unbalance relative to the thermal overload setting as follows:

$$\text{Percentage unbalance} = \frac{I_{\Delta}}{I_{\theta}} \times 100\%$$

Where:

$$I_{\Delta} = I_{\text{MAX}} - I_{\text{MIN}}$$

I_{MAX} = highest phase current

I_{MIN} = lowest phase current

I_θ = thermal overload setting

The protection operates with an inverse time characteristic defined below:

$$t = \frac{1}{(I_{\Delta}/I_{\theta})^2} \times t_m$$

where:

t = protection operating time

t_m = time multiplier setting

Figure 5 illustrates operating characteristics for two sample combinations of settings. The relay uses a lookup table to create this characteristic. The phase difference setting determines the minimum percentage phase unbalance for which the relay will operate. The time multiplier determines the maximum operating time at the unbalance setting. Note that a time multiplier of 1.0x gives an operate time of 100 seconds for an unbalance of 10%.

A further setting is used to define the minimum operate time for the protection characteristic.

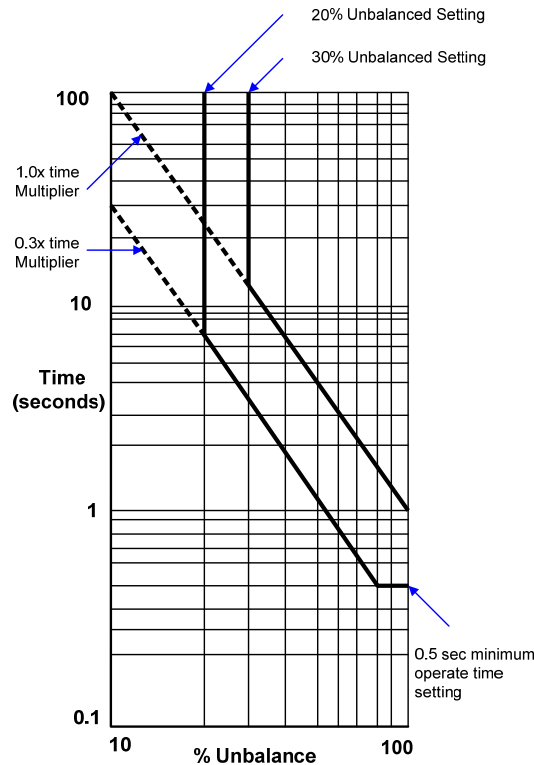

Figure 5 - Inverse time characteristics for unbalance protection

2.5.2 Negative sequence overcurrent protection

If negative phase sequence protection is selected for phase unbalance then the relay uses the negative sequence component of the three phase input currents. If the NPS overcurrent setting is exceeded then the relay operates with the same inverse time characteristic shown above for the phase difference type protection.

Hence:

$$t = \frac{1}{(I_2/I_\theta)^2} \times t_m$$

Where:

I_2 = NPS component of current

2.6 Undercurrent protection

An undercurrent element protects against the no-load condition by measuring the RMS current in each phase. Alarm and trip outputs are provided. To prevent spurious trip operations when the relay is first energised or when a motor is disconnected, the undercurrent protection does not operate for currents below the motor stopped threshold I_{STOP} .

An undercurrent alarm is given if current falls below the undercurrent alarm setting I_{UA} in any phase (but not below I_{STOP}) for longer than the definite time delay t_{UA} . A trip occurs if current falls below the undercurrent trip setting I_{UC} in any phase (but not below I_{STOP}) for longer than the definite time delay t_{UC} . The current thresholds are set as a multiple of the relay nominal current I_n . The undercurrent feature can be disabled.

The various threshold setting ranges overlap. The user is responsible for ensuring that the motor stopped threshold is set below the alarm and trip levels, otherwise this protection feature will not operate. To ensure correct discrimination between the motor stopped and loss of motor load conditions, the undercurrent protection has a minimum operate time of 200ms.

2.7 Number of starts protection

This feature permits a limit to be set on the number of times which the motor may be started within a specified time interval. Settings are provided to allow the user to select the maximum permissible number of starts and the time interval within which these starts may occur. Once the maximum permissible number of starts have occurred within the defined period then starting is inhibited for the duration of the start inhibit delay setting.

A start is detected by the relay when the current rises from zero to exceed the start current setting I_{START} already described in the section on stall and locked rotor protection. A restart is inhibited by the same output contact used for the thermal restart inhibit feature. The restart inhibit output is only energised after the motor has stopped (i.e. current falls below I_{STOP}) so that the start sequence in progress is not interrupted.

A further setting is provided to determine the minimum permissible time between two consecutive starts.

A 'Start Protection Reset' command is available in the 'Maintenance Menu' which allows the user to reset both the Number of Starts and the Min. Time Between Starts features.

2.8 Optional temperature inputs

An optional version of the relay incorporates 8 Temperature inputs to allow direct temperature monitoring of parts of the motor. The inputs are user programmable to accommodate resistance temperature detectors (RTDs) and thermistors. Different types of inputs cannot be mixed.

Each input may be independently programmed to provide alarm and trip thresholds giving instantaneous outputs.

These can all be de-activated by programming the settings to OFF.

2.8.1 RTD inputs

RTD inputs may be selected from a number of types, namely 100W Platinum (standard type DIN 43760), 100W Nickel, 120W Nickel, 10W Copper or 'other'. The named types have reasonably linear, known characteristics and the measured resistances are converted into temperatures between -50°C and $+250^{\circ}\text{C}$ on the display. Alarm and trip settings are also programmed in terms of temperature. If the 'other' type is selected then measurements and settings are displayed as resistances up to 350W.

2.8.2 Thermistor inputs

Thermistor inputs may be selected as either positive or negative temperature coefficient types (PTC or NTC). Thermistors are available with a wide range of generally non-linear characteristics and so settings and displays are given in terms of resistance. Values between 100W and 30kW are accommodated. For PTC type devices, the protection operates when resistance is measured above the applied setting. For NTC type devices, the protection operates when resistance is measured below the applied setting.

2.8.3 Detector failure protection

Each active temperature input is monitored for short circuit and open circuit failure. A temperature input fail alarm output is generated by a failure condition and the failed input is identified in the Instruments Menu. A failed device will not give a trip or alarm output. Each device is individually addressable and can be disabled. This feature can be disabled.

2.8.4 Detector gating

Further security is provided by allowing each temperature input to be AND gated with any other input. If this feature is selected then no trip will be issued unless both gated inputs detect temperature (or resistance) above the trip setting. The temperature input alarm outputs are not subject to gating.

2.9 Output contacts

The relays provide seven output relays, three of which have changeover contacts and four of which have normally open contacts.

Outputs are user programmable to operate from any or all of the protection characteristics. In addition they can be programmed to generate outputs from the I^2 summation alarm, the trip counter alarm, the status inputs and the

relay self-monitoring feature (watchdog). In their normal mode of operation, output contacts remain energised for at least 100ms, or for the duration of fault current. Alternatively, outputs can be programmed to operate as latching contacts if required. Latched output relays can be reset either by pressing the TEST/RESET button, by sending an appropriate communications command or electrically via a status input.

A trip test feature is provided to exercise the output contacts.

2.10 Status inputs

One plant status input is provided as standard, with an expanded version available with nine inputs. Each input can be programmed to perform one or more of the following functions:

- Switch to an alternative setting group
- Trigger the storage of a waveform record
- Trigger operation of the I^2 summation and trip count features
- Inhibit operation of any one or more protection functions
- Monitor the health of the tripping circuit
- Synchronise the real-time clock

Additionally, each input can be independently programmed to operate with time delayed pick-up and time delayed drop off. The status inputs have a default pick-up delay setting of 20ms which provides security against operation in the presence of an induced a.c. input voltage. If instantaneous operation is preferred then the pick-up delay should be set to zero.

2.11 Circuit breaker fail protection

A two stage circuit breaker fail feature is provided by two CBF time delays. CBF timer 1 begins to run following a trip output from any one of the protection algorithms and issues a back-trip output if current is still above setting. CBF timer 2 then begins to run and issues a second back-trip output.

2.12 Trip circuit supervision

The relay can monitor its own trip circuit by configuring one of its status inputs using the “Trip Circuit Fail” setting and connecting the input into the trip circuit (refer to the applications guide for details of how this is achieved). Indication is then given instantaneously of “Trip Circuit Failure” should a fault be detected, and this display also identifies which input has detected the fault. Since the status inputs can be programmed to operate output contacts, an alarm output can also be generated from the trip circuit supervision feature.

2.13 Multiple settings group

Relays provide eight alternative setting groups, making it possible to edit one group while the relay protection algorithms operate using another “active group”. The relay can then be switched instantaneously from one group of settings to another to suit alterations in the system configuration.

A change of group can be achieved either locally at the relay fascia, remotely via a communications interface command or automatically by energisation of a status input. In the case of the latter method, the “Settings Group Select” setting is used to configure any one (or more) of the status inputs to select a setting group. The selected group is then made active if the status input is energised and remains active for as long as the input remains energised.

3.0 OTHER FEATURES

3.1 Indications and displays

The Rho fascia includes 5 LEDs, providing indication as follows:

- Protection healthy (Green)
- Motor starting (Red)
- I>Is (Yellow)
- Trip (Red)
- Motor running (Green)

Note that the starter display applies to the phase and earth overcurrent protections as well as to the thermal protection. Additional displays relating to motor protection are also provided.

3.2 Circuit breaker maintenance

Circuit breaker condition monitoring is provided by the I^2 summation feature and the trip counter. Alarm outputs with programmable settings are available from both features.

All of this information is accessed either from the relay front panel or via the communications interface.

The values of current used for the I^2 summation are those measured at the time of issuing a trip signal. An I^2 sum is generated for each phase element and the highest value is used for alarm and display purposes.

It is also possible to initiate the I^2 summation algorithm from an external tripping device via the status input if required.

3.3 Standard displays

The metering features provide continuous data available from the relay fascia in "Instruments Display Mode" or via the communications interface. The following data is available:

- RMS current values for IA, IB, IC and IE Primary or secondary current levels can be displayed. Primary quantities are represented by upper case letters and secondary quantities by lower case
- Output relay status information is available in a bitwise manner
- Status input status information is available in a bitwise manner
- Trip circuit healthy/failure
- Trip count and summated I^2 values
- Number of waveform and event records stored
- Time and date
- The starter display indicates which poles are reading current above the main overcurrent setting

3.4 Phase sequence and phase difference ammeters

Additional ammeter displays are provided. These display the positive and negative phase sequence magnitudes I_1 and I_2 , as well as their weighted sum, equivalent current I_{eq} , as used in the thermal model. Also available is the phase difference current I_{Δ} , which is the difference between the minimum and maximum phase current magnitudes.

3.5 Motor status

This display shows 'Motor Starting' whenever the motor current exceeds the start current setting I_{START} . 'Motor Running' is then displayed when the starting sequence is complete and the current has dropped below I_{START} .

If current drops below the motor stopped current setting I_{STOP} then the display reads 'Motor Stopped'. Finally, if the relay is inhibiting motor operation then this is indicated. The display reads either 'Thermal Inhibit' or 'Starts Inhibit' for the Thermal Restart Inhibit and Number of Starts Protection Inhibit respectively.

3.6 Time to trip

If the thermal overload protection algorithm is operating for current above the thermal setting I_0 then the relay displays the predicted time to trip according to the conditions present. If no overload condition is detected then 'No Trip Expected' is displayed.

3.7 Time to start

If motor starting is being inhibited, either by the thermal restart inhibit feature following an overload trip or by the number of starts protection, then the relay can calculate and display the time which must elapse before the motor may safely start again.

When the thermal state has fallen below the restart setting then this display reads 'Start Permitted'.

3.8 Thermal capacity used

The present thermal state is displayed as a percentage of thermal capacity.

3.9 Start counter

The start counter is incremented every time the thermal equivalent current rises from zero through the start current setting I_{START} . The start counter can be reset by a command within the motor maintenance menu. Alternatively, press TEST/RESET when viewing the instrument screen. An alarm can be programmed to be issued when the start counter reaches a user defined value.

Note that the start counter feature is not related to the number of starts per period feature.

3.10 Last starting time

The relay records motor starting period from the time at which current rises through the start current setting to the time at which the current falls below the setting. This record is updated for each starting operation and is displayed in the instruments menu.

3.11 Last starting current

During the period that the starting time is being measured, the relay also monitors the thermal equivalent current magnitude and records its maximum value. This record is updated for each starting operation and is displayed in the instruments menu.

3.12 Motor running time

When the motor is running, the time elapsed since the last starting operation is displayed in hours, minutes and seconds. When the motor stops (i.e. current falls below the motor stopped setting I_{STOP}) this display holds the last running time.

3.13 Cumulative motor run time hours

A cumulative sum of total motor running time is recorded and displayed in hours, minutes and seconds. The Run Time Hours count can be reset by a command within the motor maintenance menu and an alarm can be programmed to be issued when the counter reaches a user defined value. To reset the count, press TEST/RESET when viewing the screen.

3.14 Maximum demand

The relay calculates a moving average value of the thermal equivalent current over a time window defined by the 'Maximum Demand' setting in the 'System Configuration Menu'.

The moving average value is monitored and the maximum value recorded is displayed under 'Maximum Demand' in the 'Instruments Menu'. The time and date when the maximum value was recorded is displayed under 'Maximum Demand Time', again in the 'Instruments Menu'.

The maximum demand instrument can be reset.

3.15 External trip/emergency stop

Any status input can be programmed to receive a trip signal from another device such as an emergency stop signal. The status input should firstly be mapped to the trip output contact in the output configuration menu, so that energisation of the status input results in a trip signal being issued. If the same trip contact is specified in the 'fault trigger' setting then the relay will switch to the fault data mode and indicate that an external trip has occurred.

3.16 Temperature inputs

For variants where RTD or thermistor inputs are available then the values returned by each of these are displayed. Failed inputs are identified by the word 'FAILURE'.

3.17 Default display setting and general alarms

Any one or more of the relay instrument displays can be selected as a default display by pressing the 'ENTER' key while viewing the display. A time delay should also be set using the 'Default Screen Timer' setting, found in the System Configuration Menu'. If no key is pressed for the period set then the display begins to alternate through the default instruments in turn for five seconds each.

The relay provides up to nine 'General Alarm' features. Each alarm can be activated by any one or more status inputs as selected in the 'Status Configuration Menu'. Each input can be programmed to give a unique message on the LCD, in the 'System Configuration Menu'. Whenever an alarm is activated then the display automatically jumps into 'Instruments Mode' and the 'General Alarms' screen is displayed. This screen also becomes a default display.

4 DATA RECORDS

Data records are available in three forms, namely fault records, waveform records and event records. All records are stamped with time and date. The relay incorporates a clock which keeps time even when the relay is de-energised.

Time and date can be set either via the relay fascia using appropriate commands in the System Configuration Menu, or via the communications interface. In the latter case, relays connected in a communications network can be synchronised by a global command.

Alternatively, synchronising pulses can be received via a status input. To use this feature one of the status inputs must be assigned to the "Clock Sync" feature in the Status Configuration Menu. Additionally the "Clock Sync Period" setting in the System Configuration Menu should be set either to "seconds" or to "minutes" as appropriate depending on the period of the synchronising signals expected from the controlling device. If "seconds" are selected then energisation of the selected status input will result in the clock being synchronised to the nearest second with milliseconds set to zero. If "minutes" are selected then the clock is synchronised to the nearest minute with seconds and milliseconds set to zero.

4.1 Fault records

If any protection algorithm issues a trip, then the 'Trip' LED is illuminated and one of the following messages is displayed along with a time/date stamp:

TRIP thermal
 TRIP stall
 TRIP A B C E (for Short Circuit Protection)
 TRIP unbalance
 TRIP A B C (for Undercurrent Protection)
 TRIP temperature
 TRIP external (refer to 2.9.12)
 The scrolling fault display repeats the above information in addition to:
 Current in each pole I_A , I_B , I_C , I_E
 Positive and negative sequence current magnitudes I_1 , I_2
 Thermal equivalent current I_{eq}
 Phase difference current I_Δ

The last ten fault records are stored in this format

4.2 Event records

The relay event recorder feature allows the time tagging of any change of state of the relay. Each event is logged with the full date and time and actual event condition every 2.5msec. The following events are logged:-

- Change of setting (though not the actual setting changes). Also indication of which group of setting is active
- Change of state of output relays
- Change of state of status inputs
- Change of state of any protection characteristic
- Trip Indication reset
- Trip test
- Trip supply failure
- Circuit breaker maintenance aarms
- Circuit breaker failure

The event storage buffer holds up to 500 records. When the event buffer is full, then any new record overwrites the oldest.

Event records are stored in RAM with a capacitor providing back-up during breaks in auxiliary supply.

4.3 Communications

A fibre optic communication port is provided. Communication is compatible with the IEC60870-5-103 FT 1.2 transmission and application standards. The fibre optic interface gives superior EMC performance. A user friendly software package is available to allow transfer of the following:

- Relay settings
- Waveform records
- Event records
- Instruments and meters
- Control functions

Communications operation is described in detail elsewhere in this manual.

4.4 Self monitoring

The Relay incorporates a number of self-monitoring features. Each of these initiates a reset sequence which can be used to generate an alarm output. In addition, the Protection Healthy LED gives visual indication.

A watchdog feature monitors the microprocessor. The relay program memory is continuously checked for data corruption using a CRC routine.

The power supply is continuously supervised. Any failure is detected with sufficient time warning so that the microprocessor can be shut down in a safe and controlled manner.

4.5 Password feature

The programmable password feature enables the user to enter a 4 character alpha-numeric code. As soon as the user attempts to change a setting the password is requested before any setting alternations are allowed. Once the password has been validated, the user is said to be “logged on” and if no further changes are made within 1 hour then the user will automatically be “logged out”, re-enabling the password feature.

Note that the password validation screen also displays a numerical code. If the password is lost or forgotten, this code can be communicated to Reyrolle Protection by authorised personnel, and the password can be retrieved.

The relay is supplied with the password set to “NONE” which means the feature is de-activated.

5 USER INTERFACE

The user interface is designed to provide a user-friendly method of entering settings and retrieving data from the relay.

5.1 General arrangement

The relay fascia includes a 16 character by 2 line, backlit, liquid crystal display, 5 light emitting diodes and 5 push buttons.

5.2 Liquid crystal display

The liquid crystal display is used to present settings, instruments and fault data in a textual format.

The display backlighting is turned off to conserve power if no pushbuttons are pressed for 5 minutes. After an hour, the whole display is de-activated, except in the case of the default screens, which remain visible permanently.

5.3 LED indications

The following indications are provided:

PROTECTION HEALTHY - Green LED, flashes with fault.

This LED indicates that DC volts have been applied to the relay and that the relay is operating correctly. If a permanent fault is detected by the internal relay watchdog, then this LED will continuously flash.

TRIP - Red LED latched

This LED indicates that a trip, as defined by the user, has occurred. Such a trip may have been issued by any of the relay's protection functions. The user will be given more detailed information concerning the relay operation from the LCD.

I > Is (STARTER) - Yellow LED self-resetting

This LED indicates that any pole is measuring current above the thermal current setting or high set overcurrent.

MOTOR STARTING - Red LED, self-resetting

This LED indicates when the current exceeds the motor starting current.

MOTOR RUNNING - Green LED, self-resetting

This LED indicates that the relay current is greater than the motor stop current but less than the motor starting current.

5.4 Keypad

Five push buttons are used to control the functions of the relay by moving around the menu display. They are labelled ENTER and CANCEL. Note that the button is also labelled TEST/RESET.

Only two push buttons are accessible when the front cover is on. These are the and buttons, allowing read access to all displays.

6 SETTINGS AND DISPLAYS

The basic setting/display flow diagram is shown in figure 6. This diagram shows the three main modes of display, the Setting Display Mode, the Instrument Display Mode and the Fault Data Display Mode.

On relay start up, the user is presented with a default relay identifier. This can be changed to some user definable identifier or code if the user prefers.

Settings display mode is entered by scrolling down from the relay identifier display. The key can then be used to move to the Instrument and Fault Data Display Modes in turn.

The settings display mode contains all the menus which hold the programmable settings of the relay.

A sub menu is opened by pressing the key when viewing one of the title screens. The settings within the sub-menu can then be viewed in turn. Leaving a sub-menu, by scrolling either upwards or downwards, causes it to be automatically closed. It must be reopened in order to view its settings again.

1. Pressing / scrolls up/down, viewing the screens. All screens can be viewed even if the password is not known - the password only protects the relay against unauthorised changes.

2. While viewing an editable screen, ENTER allows the user to change the displayed data, indicated by flashing character, as long as the changes are authorised via password verification. Pressing / increments/decrements that particular character, while moves right along the edit field or fields. If or are held pressed while scrolling through a range of numerical settings then the rate of scrolling increases.

3. CANCEL returns the screen to view mode and restores the setting.

4. If changes are made, pressing ENTER alters the values on that screen and immediately stores the changes into non-volatile memory. This also returns the screen to view mode and allows / to move to the previous/next screen.

There are eight separate "Settings Groups", allowing the relay to be easily switched from one group to another. Grouped settings are found in the protection, O/P relay configuration, status configuration sub-menus and in part of the data storage sub-menu. All other settings are common. The different settings groups can be viewed or edited independently and indication of which group is presently being viewed is given by the "G?" character in the top left of the display.

A description of the purpose of each relay setting, the actual setting ranges and default values can be found elsewhere in this manual.

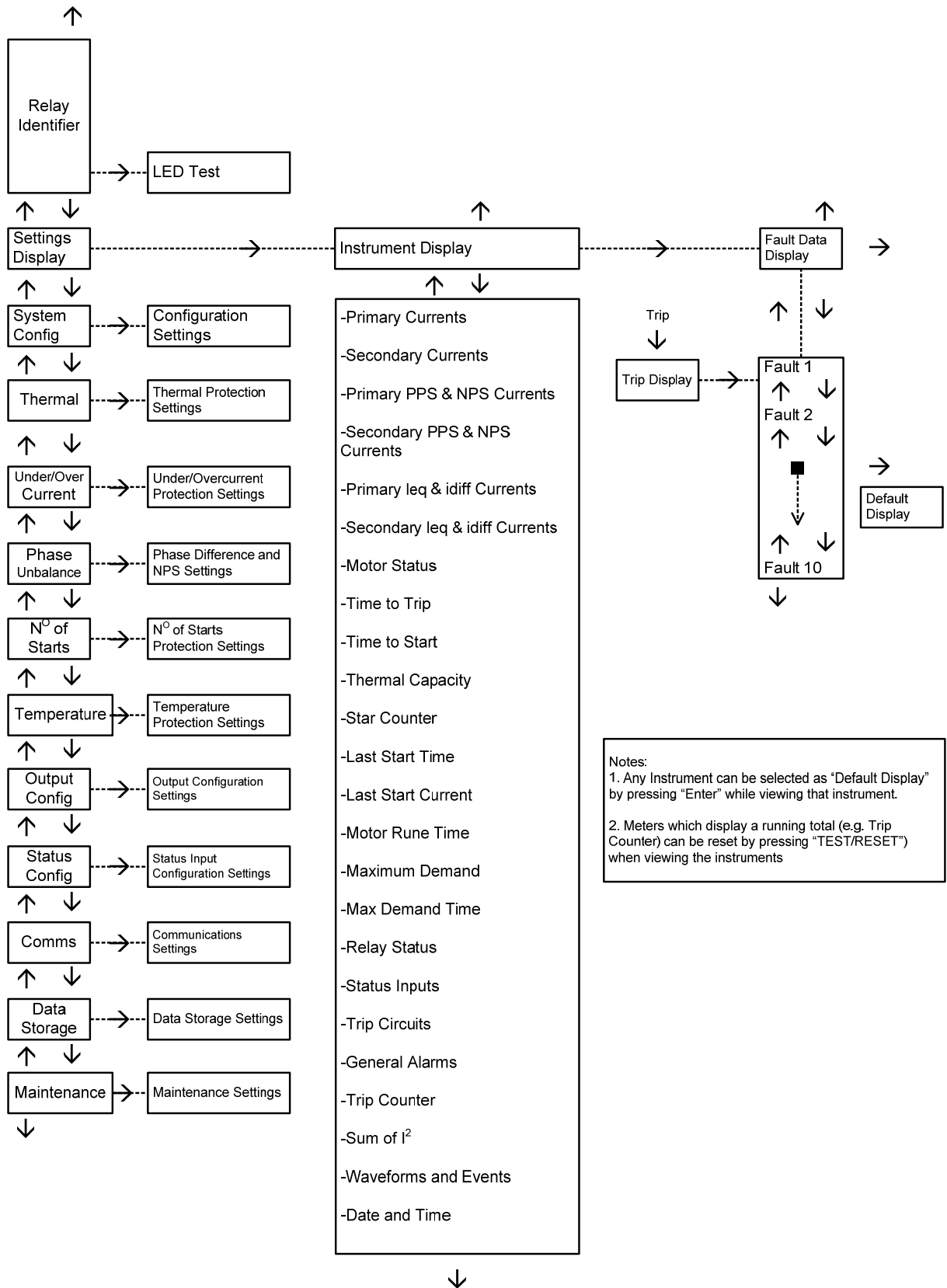

7 RELAY HARDWARE

7SG17 relays are housed in the Epsilon case, with 2 case sizes being necessary to cover the available variants - E6 and E8. Figure 7 shows the Relay HMI layout.

7.1 Internal construction

Relays without temperature detector are housed in E6 cases, those with detectors in E8 cases.

The design for the internal arrangement of each case has been chosen to provide a high level of EMI screening, using multi-layer PCB's with ground planes, RFI suppression components and earthed metal screens.

The cases have been divided internally into noisy and quiet areas in order to improve noise immunity and reduce RFI emissions. The only direct connection from the quiet components to the external environment is via the optical serial communications interface, which is immune to radiated or conducted interference.

7.2 Front cover

This allows access to the and buttons, allowing all of the menus discussed previously to be viewed but not changed. The only "action" which is permitted is to reset the Fault Data Display, latched output relays and the trip LED by using the TEST/RESET function of the button.

7.3 Terminal blocks

These are of the standard Epsilon design, consisting of 28 terminals per block, with either one or two blocks depending on the variant of the relay. All inputs and outputs (except for the serial communications interface) are made through these connectors. The fibre optic serial communication cables are connected via SMA connectors.

Features

- 1 Relay type
- 2 Red LED - motor starting
- 3 Yellow LED
- 4 Page-up key
- 5 Page-down key
- 6 Green LED protection healthy
- 7 Contrast adjustment
- 8 LCD display (backlit)
- 9 Green LED - motor running
- 10 Red LED - relay trip
- 11 Enter key
- 12 Test and reset key - also enables sub-menu access
- 13 Cancel key

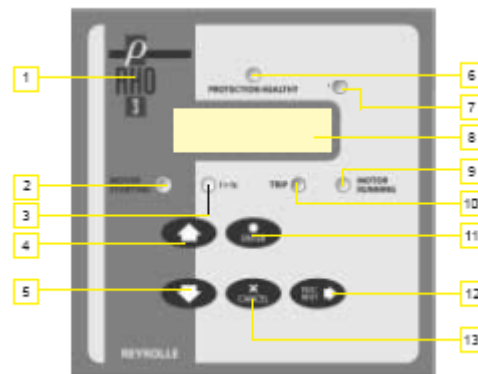

Figure 7 - Rho 3 HMI layout

EVENT	Code	GI	Type	EVENT	Code	GI	Type
Data lost	0	x	1	A- Overcurrent starter	64	x	2
Reset PCB	2	x	5	B- Overcurrent starter	65	x	2
Reset CU	3	x	5	C- Overcurrent starter	66	x	2
Start/restart	4	x	5	E/F-Starter	67	x	2
Power On	5	x	5	General Trip	68	x	2
A-Undercurrent alarm starter	6	x	1	A- Overcurrent trip	69	x	2
B-Undercurrent alarm starter	7	x	1	B- Overcurrent trip	70	x	2
C-Undercurrent alarm starter	8	x	1	C- Overcurrent trip	71	x	2
A-Undercurrent alarm	9	✓	1	E/F trip	72	x	2
B-Undercurrent alarm	10	✓	1	E/F-Alarm starter	73	x	1
C-Undercurrent alarm	11	✓	1	E/F-Alarm	74	✓	1
A-Undercurrent starter	12	x	2	Stall delay 1 starter	75	x	1
B-Undercurrent starter	13	x	2	Stall delay 1 trip	76	x	1
C-Undercurrent starter	14	x	2	Stall delay 2 starter	77	x	1
A-Undercurrent trip	15	x	2	Stall delay 2 trip	78	x	1
B-Undercurrent trip	16	x	2	Max. starts exceeded	79	✓	1
C-Undercurrent trip	17	x	2	Wavetorm stored	80	x	1
External trip	18	x	1	Remote control interrupted	81	x	1
LEDs reset	19	x	1	Start counter alarm	82	✓	1
Trip circuit fail	20	✓	1	Run-time hours alarm	83	✓	1
Test mode (Trip test)	21	x	1	General starter	84	✓	2
Setting changed	22	x	1	Circuit breaker fail 1	85	x	2
Setting group 1 selected	23	✓	1	Motor stopped	86	✓	1
Setting group 2 selected	24	✓	1	Motor running	87	✓	1
Setting group 3 selected	25	✓	1	Motor starting	88	✓	1
Setting group 4 selected	26	✓	1	Motor start inhibit	89	✓	1
Input 1	27	✓	1	Temp Input 1 alarm	90	✓	1
Input 2	28	✓	1	Temp Input 2 alarm	91	✓	1
Input 3	29	✓	1	Temp Input 3 alarm	92	✓	1
Input 4	30	✓	1	Temp Input 4 alarm	93	✓	1
Phase unbalance starter	31	x	2	Temp Input 5 alarm	94	✓	1
Phase unbalance trip	32	x	2	Temp Input 6 alarm	95	✓	1
Trip count alarm	33	✓	1	Temp Input 7 alarm	96	✓	1
CB maintenance alarm	34	✓	1	Temp Input 8 alarm	97	✓	1
Setting group 5 selected	35	✓	1	Temp Input 1 trip	98	x	1
Setting group 6 selected	36	✓	1	Temp Input 2 trip	99	x	1
Setting group 7 selected	37	✓	1	Temp Input 3 trip	100	x	1
Setting group 8 selected	38	✓	1	Temp Input 4 trip	101	x	1
Circuit breaker fail 2	39	x	2	Temp Input 5 trip	102	x	1
Thermal overload alarm	40	✓	1	Temp Input 6 trip	103	x	1
Thermal capacity alarm	41	✓	1	Temp Input 7 trip	104	x	1
Thermal overload trip	42	x	1	Temp Input 8 trip	105	x	1
Load increase alarm	43	✓	1	Temp Input 1 fail	106	✓	1
Thermal restart inhibit	44	✓	1	Temp Input 2 fail	107	✓	1
Input 5	45	✓	1	Temp Input 3 fail	108	✓	1
Input 6	46	✓	1	Temp Input 4 fail	109	✓	1
Input 7	47	✓	1	Temp Input 5 fail	110	✓	1
Input 8	48	✓	1	Temp Input 6 fail	111	✓	1
Input 9	49	✓	1	Temp Input 7 fail	112	✓	1
E/F Inhibit	50	✓	1	Temp Input 8 fail	113	✓	1
Output 1	51	✓	1	General alarm 1	121	✓	1
Output 2	52	✓	1	General alarm 2	122	✓	1
Output 3	53	✓	1	General alarm 3	123	✓	1
Output 4	54	✓	1	General alarm 4	124	✓	1
Output 5	55	✓	1	General alarm 5	125	✓	1
Output 6	56	✓	1	General alarm 6	126	✓	1
Output 7	57	✓	1	General alarm 7	127	✓	1
A-Overcurrent alarm starter	58	x	1	General alarm 8	128	✓	1
B-Overcurrent alarm starter	59	x	1	General alarm 9	129	✓	1
C-Overcurrent alarm starter	60	x	1				
A-Overcurrent alarm	61	✓	1				
B-Overcurrent alarm	62	✓	1				
C-Overcurrent alarm	63	✓	1				

Table 2 - Rho 3 private event codes (function code 165)

7SG17 Rho 3

Multifunction Protection Relays

Document Release History

This document is issue 2010/02. The list of revisions up to and including this issue is:

Pre release

2010/02	Document reformat due to rebrand

Software Revision History

--	--	--

The copyright and other intellectual property rights in this document, and in any model or article produced from it (and including any registered or unregistered design rights) are the property of Siemens Protection Devices Limited. No part of this document shall be reproduced or modified or stored in another form, in any data retrieval system, without the permission of Siemens Protection Devices Limited, nor shall any model or article be reproduced from this document unless Siemens Protection Devices Limited consent.

While the information and guidance given in this document is believed to be correct, no liability shall be accepted for any loss or damage caused by any error or omission, whether such error or omission is the result of negligence or any other cause. Any and all such liability is disclaimed.

Contents

Contents	2
1 GENERAL.....	3
2 CHARACTERISTIC ENERGIZING	3
3 AUXILIARY ENERGIZING QUANTITY	3
3.1 DC power supply	3
3.2 DC status inputs	3
4 CHARACTERISTICS	4
4.1 Thermal protection settings	4
4.2 Over/undercurrent settings	4
4.3 Phase unbalance settings	5
4.4 Number of starts protection	5
4.5 Temperature Inputs	5
5 Accuracy Reference Conditions	5
5.1 Accuracy.....	5
5.2 Accuracy general.....	6
5.3 Accuracy influencing factors	6
6. Thermal Withstand.....	7
7. Burdens	8
8. Output Contact Performance	8
9. Environmental Withstand	8

1 GENERAL

Performance data to:
IEC60255-3 and IEC60255-8.

2 CHARACTERISTIC ENERGIZING

QUANTITY

AC Current In	1A/5A
Frequency	50/60Hz

3 AUXILIARY ENERGIZING QUANTITY

3.1 DC power supply

Nominal Operating range

	Nominal voltage	Operating range
VAUX	24,30,48V	18V to 60V dc
	110,220V	88V to 280V dc

3.2 DC status inputs

Nominal voltage	Operating range
30/34	18V to 37.5V
48/54	37.5V to 60V
110/125	87.5V to 137.5V
220/250	175V to 280V

NB Status operating voltage need not be the same as the main energising voltage. For 110/125 volt or 220/250 volt working, a standard Rho 3 relay with 48/54 volt status will be supplied for use with external dropper resistors as follows:-

Status input external resistances

Nominal voltage	Resistor value; wattage
110/125V	2k7 \pm 5% ; 2.5W
220/250V	8k2 \pm 5% ; 6.0W

Status input performance

Minimum DC current for operation	10mA
Reset/operate voltage ratio	\geq 90%
Typical response time	< 5ms
Typical response time when programmed to energise an output relay contact	< 15ms
Minimum pulse duration	40ms

Each status input has associated timers which can be programmed to give time delayed pick-up and time delayed drop-off. The drop-off timers have default settings of 20ms, thus providing immunity to an AC input signal. Status inputs will not respond to the following:

- 250V RMS 50/60Hz applied for two seconds through a 0.1 μ F capacitor.
- Discharge of a 10 μ F capacitor charged to maximum DC auxiliary supply voltage.

The status inputs perform according to the requirements of ESI48-4 ESI 1.

Note that alternative status inputs can be ordered, which can be driven directly from 110V or 220V, without a dropper resistor. These special low current types will operate with input currents of less than 10mA.

4 CHARACTERISTICS

4.1 Thermal protection settings

Thermal setting I_{θ}	0.50 to 2.00 xIn Δ 0.05xIn
NPS weighting factor 'K'	0.0 to 10.0 Δ 0.1
Heating constant τ_h	0.5 to 100.0 mins Δ 0.5 min
Starting constant τ_s	0.50 to 1.50 x τ_h Δ 0.05
Cooling constant τ_c	1 to 100 x τ_h Δ 1
Hot/cold ratio	OFF, 5 to 100% Δ 5%
Thermal capacity alarm	OFF, 50 to 100% Δ 1%
Load Increase alarm	OFF, 0.5 to 1.0 x I_{θ} Δ 0.05 x I_{θ}
Thermal restart inhibit	20 to 100% Δ 1%
Operate time (cold), mins see figure 1.	$t = \tau \cdot \text{Ln} \frac{I_{\text{eq}}^2}{I_{\text{eq}}^2 - (I_{\theta})^2}$
Operate time (hot) for prior current I_p , mins	$t = \tau \cdot \text{Ln} \frac{I_{\text{eq}}^2 - \left(I - \frac{H}{C}\right) I_p^2}{I_{\text{eq}}^2 - (I_{\theta})^2}$
Motor start current I_{START}	1.5 to 4.0 x I_{θ} Δ 0.1 x I_{θ}
Motor stop current I_{STOP}	0.05 to 0.20 x I_{θ} Δ 0.05 I_{θ}
Stall withstand delay 1 t_{s1}	OFF, 1 to 250sec Δ 1sec
Stall withstand delay 2 t_{s2}	OFF, 1 to 250sec Δ 1sec
CB fail delay 1	OFF, 1 to 20sec Δ 0.01sec
CB fail delay 2	OFF, 1 to 20sec Δ 0.01sec

Note 1: the thermal algorithm operates on an equivalent thermal current, I_{eq} , which is a combination of the positive and negative phase sequence components, I_1 and I_2 :

$$I_{\text{eq}} = \sqrt{I_1^2 + K \cdot I_2^2}$$

Note 2: the thermal algorithm operates using one of () three time constants (τ_h , τ_s or τ_c), chosen according to the magnitude of I_{eq} as follows:

- If $I_{\text{eq}} < I_{\text{STOP}}$ then $\tau = \tau_c$ (cooling condition)
- If $I_{\text{STOP}} \leq I_{\text{eq}} < I_{\text{START}}$ then $\tau = \tau_h$ (running condition)
- If $I_{\text{eq}} \geq I_{\text{START}}$ then $\tau = \tau_s$ (starting condition).

Note 3: While the Hot/Cold ratio setting is entered as a percentage value, the factor H/C which appears in the equation for the Operate Time (Hot Curve) is actually a per-unit value.

Figure 1 and Figure 2 illustrate examples of cold and hot curves.

4.2 Over/undercurrent settings

P/F alarm I_{HA}	OFF, 0.5 to 20xIn Δ 0.1xIn
P/F alarm delay t_{HA}	0.0 to 1.0sec Δ 0.01sec 1.0 to 30.0sec Δ 0.1sec
P/F trip I_{HS}	OFF, 0.5 to 20xIn Δ 0.1xIn
P/F trip delay t_{HS}	0.0 to 1.0sec Δ 0.01sec 1.0 to 30.0sec Δ 0.1sec
E/F alarm I_{EA}	OFF, 0.005 to 1.000xIn Δ 0.005xIn
E/F alarm delay t_{EA}	0.0 to 1.0sec Δ 0.01sec 1.0 to 30.0sec Δ 0.1sec
E/F trip I_{EF}	OFF, 0.005 to 1.000xIn Δ 0.005xIn
E/F trip delay t_{EF}	0.0 to 1.0sec Δ 0.01sec 1.0 to 30.0sec Δ 0.1sec

E/F inhibit I_{EI}	OFF, 4.0 to 10.0xIn Δ 0.1xIn
U/C alarm I_{UA}	OFF, 0.10 to 1.50xIn Δ 0.05xIn
U/C alarm delay t_{UA}	0.2 to 30.0sec Δ 0.1sec
U/C trip I_{UC}	OFF, 0.10 to 1.50xIn Δ 0.05xIn
U/C trip delay t_{UC}	0.2 to 30.0sec Δ 0.1sec

4.3 Phase unbalance settings

Phase difference $I_{\Delta} = I_{MAX} - I_{MIN}$	0.10 to 0.40xI _θ Δ 0.05xI _θ
Negative seq. I_2	0.10 to 0.40xI _θ Δ 0.05xI _θ
Time multiplier	0.025 to 2.000x I _θ Δ 0.025xI _θ
Min. Op. Time	0.1 to 2.0 sec Δ 0.1sec
Operate time - Phase difference, secs	$t = \frac{1}{\left(\frac{I_{\Delta}}{I_{\theta}}\right)^2} \times t_m$
Operate time - Negative sequence, secs	$t = \frac{1}{\left(\frac{I_2}{I_{\theta}}\right)^2} \times t_m$

4.4 Number of starts protection

Max. starts	OFF, 1 to 20 Δ 1
Max. starts period	1 to 60 mins Δ 1 min
Start inhibit delay	1 to 60 mins Δ 1 min
Min. time between starts	OFF, 1 to 60 mins Δ 1 min

4.5 Temperature Inputs

Input Type	Range for alarm and trip
RTD (100Ω Pt, 100Ω Ni, 120Ω Ni, 10Ω Cu)	0 – 250°C Δ 1°
Other RTD	100 – 350Ω Δ 1 Ω
Thermistor (PTC, NTC)	100 - 1000 Ω Δ 10Ω 1100 - 30000Ω Δ 100 Ω

5 Accuracy Reference Conditions

General	IEC60255-3 IEC60255-8
Auxiliary Supply	Nominal
Frequency	50/60Hz
Ambient temperature	20°C

5.1 Accuracy

Current Settings		
Thermal, stall, unbalance and phase fault overcurrent protections	Operate	± 5%
	Reset	≥ 95% of operating current
Earth fault protection	Operate	± 5% or ± 1mA
	Reset	≥ 95% of operating current (1mA)
Undercurrent protection	Operate	± 5%
	Reset	≥ 105% of operating current
All settings	Repeatability	± 1%

Time Settings		
Thermal protection	Accuracy	± 5% or ± 100ms
	Repeatability	± 100ms
Unbalance protection	Accuracy	± 5% or ± 50ms
	Repeatability	± 50ms
Independent times - ie phase fault, earth fault, undercurrent and stall protections	Accuracy	± 1% or ± 30ms
	Repeatability	± 1%

Note:

- Where unbalance protection is configured in NPS mode, the claim assumes a period of balanced 3 phase operation prior to the unbalance occurring. In the case of the relay being switched onto an unbalanced system 'from cold', then an additional 100ms may be required for the NPS algorithm to stabilise.
- It is advised that the unbalance protection should not be configured in phase difference mode when operating on 60Hz systems.

Temperature protection	
RTD (100Ω Pt, 100Ω Ni, 120Ω Ni)	± 2 ^o C
RTD (10 Ω Cu)	± 5 ^o C
Other RTD	± 1Ω
Thermistor (PTC, NTC)	± 5%

5.2 Accuracy general

Transient overreach of phase fault protection for X/R = 100	≤ -5%
Disengaging time	< 42ms
Overshoot time	< 40ms

Note:

Output contacts have a minimum dwell time of 100ms, after which the disengaging time is as above.

5.3 Accuracy influencing factors

Temperature

Ambient range	-10 ^o C to +55 ^o C
Variation over range	≤ 5%

Frequency

Range	47Hz to 52Hz 57Hz to 62Hz
Setting variation	≤ 5%
Operating time variation	≤ 5%

Harmonic content

Harmonic content of waveforms	Frequencies to 550Hz
Operating time variation	≤ 5%

High frequency disturbance – IEC60255-22-1 Class III

	Variation
2.5kV common (longitudinal) mode	≤ 3%
1.0kV series (transverse) mode	≤ 3%

Electrostatic frequency interference – IEC60255-22-2 Class III

	Variation
8kV common discharge	≤ 5%

Radio frequency interference – IEC60255-22-3 Class III

	Variation
20MHz to 1000MHz, 10 V/m	≤ 5%

Fast transient – IEC60255-22-4 Class IV

	Variation
4kV 5/50ns 2.5Hz repetitive	≤ 3%

Vibration (sinusoidal) – IEC60255-21-1 Class I

		Variation
Vibration response	0.5gn	≤ 5%
Vibration endurance	1.0gn	≤ 5%

Shock and bump – IEC60255-21-2 Class I

		Variation
Shock response	5gn 11ms	≤ 5%
Shock withstand	15gn 11ms	≤ 5%
Bump test	10gn 16ms	≤ 5%

Seismic – IEC60255-21-3 Class I

		Variation
Seismic response	1gn	≤ 5%

Mechanical Classification

Durability	In excess of 10 ⁶ operations
------------	---

Auxiliary DC Supply – IEC60255-11

Allowable superimposed as component	≤ 12% of DC voltage
Allowable breaks/dips in supply (collapse to zero from nominal voltage)	≤ 20ms

6. Thermal Withstand

Continuous and limited period overload

3.0 x I _n	Continuous
3.5 x I _n	For 10 minutes
4.0 x I _n	For 5 minutes
5.0 x I _n	For 3 minutes
6.0 x I _n	For 2 minutes

Short term overload

5A Phase / earth	400A for 1 sec
	282A for 2 sec
	230A for 3 sec
	2500A for 1 cycle
1A Phase / Earth	100A for 1 sec

	70.7A for 2 sec
	57.7A for 3 sec
	700A for 1 cycle

7. Burdens

	AC burden	Impedance
5A Phase	$\leq 0.2VA$	$\leq 0.01\Omega$
1A Phase	$\leq 0.05VA$	$\leq 0.05VA$
5A Earth	$\leq 0.4VA$	$\leq 0.02VA$
1A Earth	$\leq 0.2VA$	$\leq 0.2VA$

NB: Burdens and impedances are measured at nominal current rating

	DC burden
Quiescent (typical)	3 Watts
Max	10 Watts

8. Output Contact Performance

Contact rating to IEC60255-0-2

Carry continuously 5A ac of dc

Make and carry

(limit L/R $\leq 40ms$ and V ≤ 300 volts)

For 0.5 sec	20A ac or dc
For 0.2 sec	30A ac or dc

Break

(limit $\leq 5A$ or ≤ 300 volts)

ac resistive	1250VA
ac inductive	250VA @ PF ≤ 0.4
dc resistive	75W
dc inductive	30W @ L/R $\leq 40ms$ 50W @ L/R $\leq 10ms$

9. Environmental Withstand

Temperature – IEC6068-2-1/2

Operating range	$-10^{\circ}C$ to $+55^{\circ}C$
Storage range	$-25^{\circ}C$ to $+70^{\circ}C$

Humidity – IEC6068-2-3

Operational test	56 days at $40^{\circ}C$ and 95% RH
------------------	-------------------------------------

Transient overvoltage

Between all terminals and earth or between any two independent circuits without damage of flashover	5kV 1.2/50 μ s 0.5J
---	-------------------------

Insulation – IEC60255-5

Between all terminals and earth	2.0kV ms for 1 min
Between independent circuits	2.0kV ms for 1 min
Across normally open contacts	1.0kV ms for 1 min

Current (multiples of setting)	Operate time t for various time constraints (seconds)										
	0.5 (mins)	1 (mins)	2 (mins)	3 (mins)	5 (mins)	10 (mins)	15 (mins)	20 (mins)	30 (mins)	50 (mins)	100 (mins)
1.2	35.57	71.14	142.27	213.41	355.69	711.37	1067.06	1422.75	2134.12	3556.87	7113.74
1.5	17.63	35.27	70.53	105.80	176.34	352.67	529.01	705.34	1058.02	176.36	3526.72
2.0	8.63	17.26	34.52	51.78	86.30	172.61	258.91	345.22	517.83	863.05	1726.09
2.5	5.23	10.46	20.92	31.38	52.31	104.61	156.92	209.22	313.84	523.06	1046.12
3.0	3.53	7.07	14.13	21.20	35.33	70.67	106.00	141.34	212.01	353.35	706.70
3.5	2.55	5.11	10.22	15.33	25.55	51.09	76.64	102.19	153.28	255.47	510.95
4.0	1.94	3.87	7.74	11.62	19.36	38.72	58.08	77.45	116.17	193.62	387.23
4.5	1.52	3.04	6.08	9.12	15.19	30.39	45.58	60.77	91.16	151.93	303.86
5.0	1.22	2.45	4.90	7.35	12.25	24.49	36.74	48.99	73.48	122.47	244.93
5.5	1.01	2.02	4.03	6.05	10.08	20.17	30.25	40.34	60.51	100.85	201.70
6.0	0.85	1.69	3.38	5.07	8.45	16.90	25.35	33.81	50.71	84.51	169.03
7.0	0.62	1.24	2.47	3.71	6.19	12.37	18.56	24.74	37.11	67.86	123.72
8.0	0.47	0.94	1.89	2.83	4.72	9.45	14.17	18.90	28.35	47.25	94.49
9.0	0.37	0.75	1.49	2.24	3.73	7.45	11.18	14.91	22.36	37.27	74.54
10.0	0.30	0.60	1.21	1.81	3.02	6.03	9.05	12.06	18.09	30.15	60.30

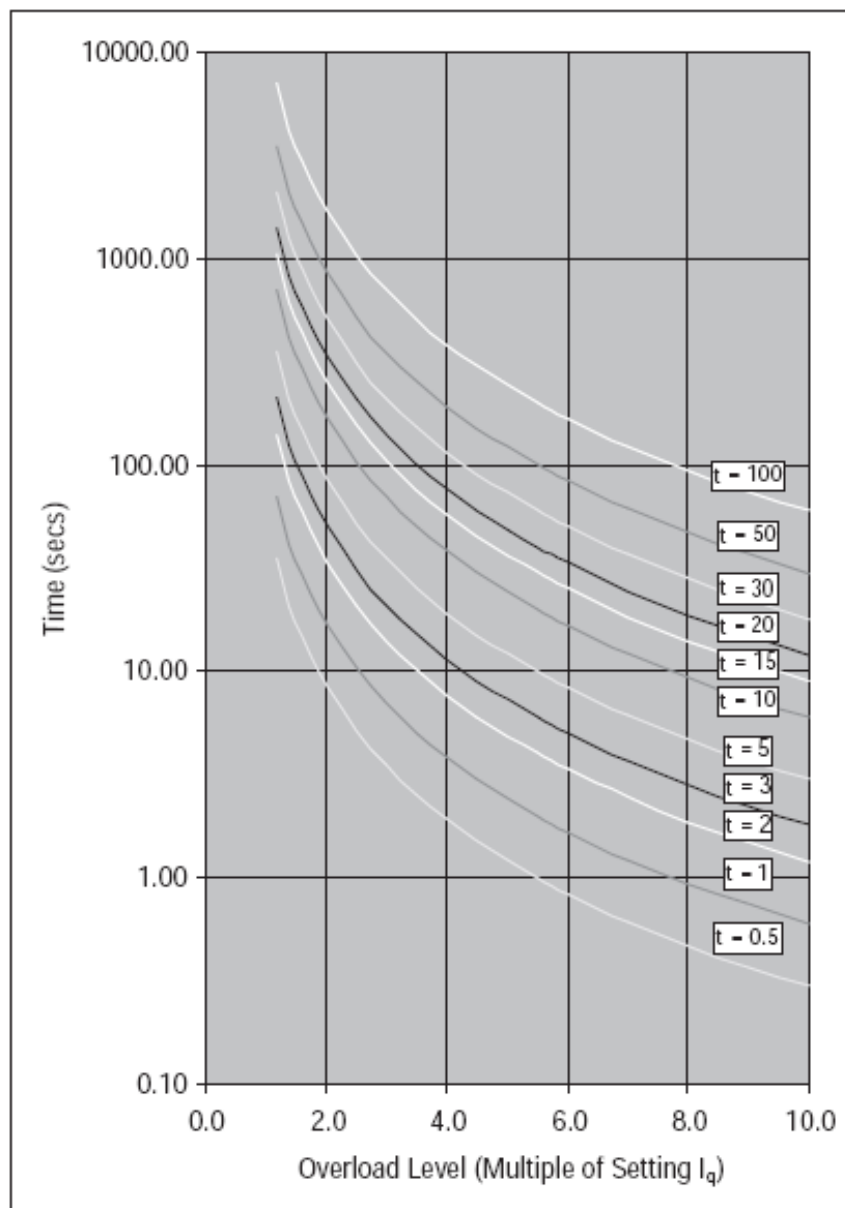

Figure 1 IEC60255-8 cold curve operate times for varying time constants
NB. operate times are in seconds, time constants are set in minutes

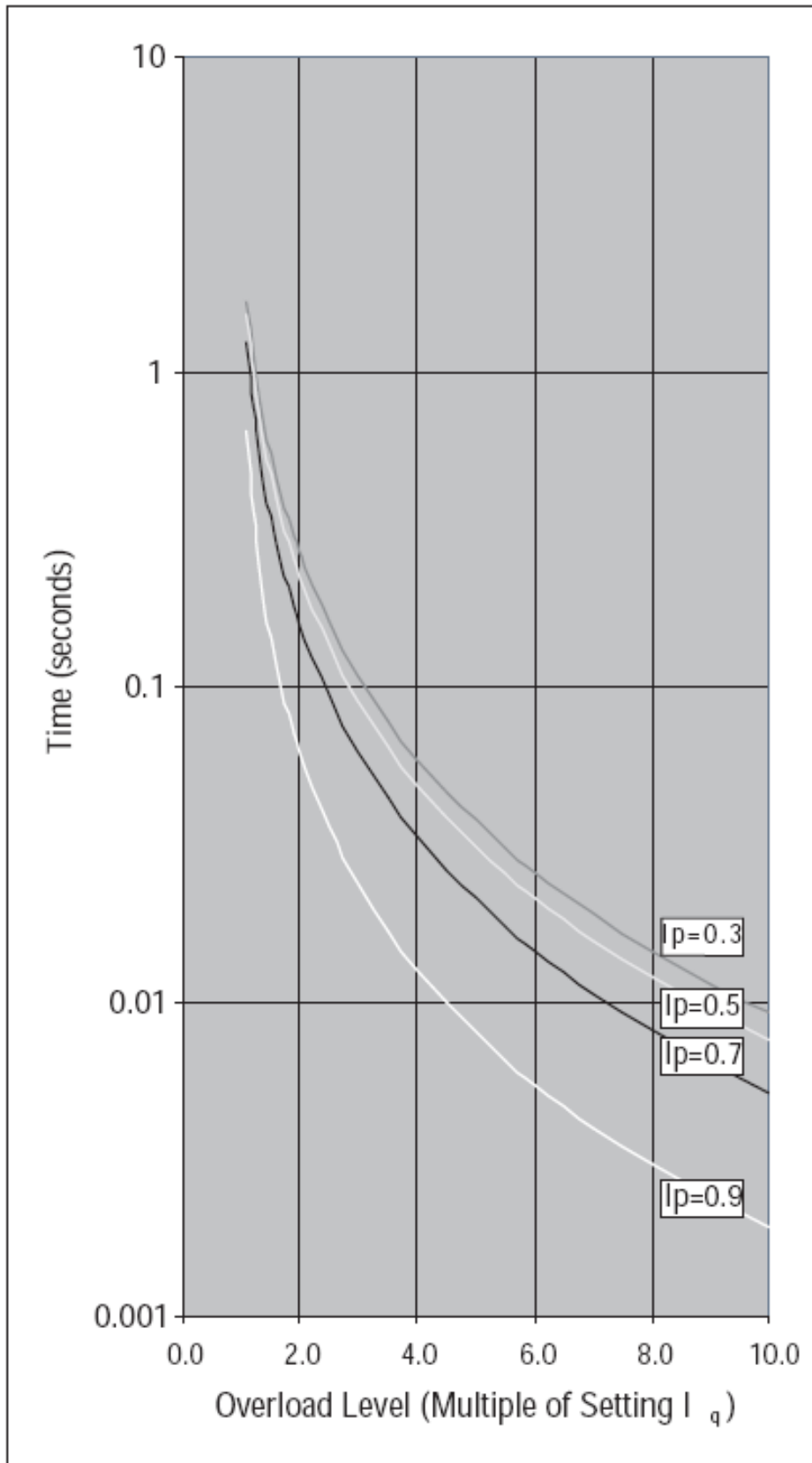

Figure 2 IEC60255-8 hot curves for varying levels of prior load current
 NB. operate times are in seconds, time constants are set in minutes

7SG17 Rho 3

Multifunction Protection Relays

Document Release History

This document is issue 2010/02. The list of revisions up to and including this issue is:

Pre release

2010/02	Document reformat due to rebrand

Software Revision History

--	--	--

The copyright and other intellectual property rights in this document, and in any model or article produced from it (and including any registered or unregistered design rights) are the property of Siemens Protection Devices Limited. No part of this document shall be reproduced or modified or stored in another form, in any data retrieval system, without the permission of Siemens Protection Devices Limited, nor shall any model or article be reproduced from this document unless Siemens Protection Devices Limited consent.

While the information and guidance given in this document is believed to be correct, no liability shall be accepted for any loss or damage caused by any error or omission, whether such error or omission is the result of negligence or any other cause. Any and all such liability is disclaimed.

Contents

- 1 SYSTEM CONFIGURATION MENU..... 3
- 2 THERMAL PROTECTION MENU..... 3
- 3 OVER/UNDER CURRENT PROTECTION MENU..... 4
- 4 PHASE UNBALANCE PROTECTION MENU..... 4
- 5 NUMBER OF STARTS PROTECTION MENU 4
- 6 TEMPERATURE PROTECTION MENU 4
- 7 OUTPUT CONFIGURATION MENU..... 5
- 8 STATUS CONFIGURATION MENU 6
- 9 COMMUNICATIONS INTERFACE MENU..... 7
- 10 DATA STORAGE MENU 7
- 11 MAINTENANCE MENU 7

1 SYSTEM CONFIGURATION MENU

SETTING	RANGE	DEFAULT
Active settings group	1 - 8	1
Settings group edit / view	1 - 8	1
Copy group	From *	From G1 to G2
Power system frequency	50Hz or 60Hz	50Hz
P/F rating (In)	1A or 5A	1A
E/F rating (In)	1A or 5A	1A
P/F CT ratio	5 to 10,000 step 5 : 1 or 5	300:1
E/F CT ratio	5 to 10,000 step 5 : 1 or 5	300:1
Current display	xIn , PRIMARY or SECONDARY	xIn
Maximum demand	1 to 60 minutes step 1	15 min
Set identifier	Up to 16 alphanumeric characters	RHO 3
Set alarm 1	Up to 13 alphanumeric characters	ALARM 1
Set alarm 2	Up to 13 alphanumeric characters	ALARM 2
Set alarm 3	Up to 13 alphanumeric characters	ALARM 3
Set alarm 4	Up to 13 alphanumeric characters	ALARM 4
Set alarm 5	Up to 13 alphanumeric characters	ALARM 5
Set alarm 6	Up to 13 alphanumeric characters	ALARM 6
Set alarm 7	Up to 13 alphanumeric characters	ALARM 7
Set alarm 8	Up to 13 alphanumeric characters	ALARM 8
Set alarm 9	Up to 13 alphanumeric characters	ALARM 9
Calendar - set date	DD/MM/YY	01/01/99
Clock - set time	HH:MM:SS	00:00:00
Clock sync. from status	Seconds or Minutes	Minutes
Default screen timer	10 sec, 60 sec, 5 min, 1 hour	5 min
Change password	4 alphanumeric characters	NONE

*From any group to any other group

2 THERMAL PROTECTION MENU

SETTING	RANGE	DEFAULT
Gn thermal overload setting (I_{θ})	0.20 - 2.00 x In step 0.01	1.05 x In
Gn NPS weighting factor (K)	0.0 - 10.0 step 0.1	3.0
Gn heating time constant (τ_{η})	0.5 - 100.0 mins step 0.5	10.0 mins
Gn starting time constant (τ_s)	0.50 - 1.50 x th step 0.05	1.00 x τ_{η}
Gn cooling time constant (τ_c)	1 - 100 x th step 1	10 x τ_{η}
Gn hot/cold curve ratio	OFF, 5 - 100% step 5	OFF
Gn thermal capacity alarm setting	OFF, 50 - 100% step 1	OFF
Gn load increase alarm setting	OFF, 0.50 - 1.00 x Iq step 0.05	OFF
Gn thermal restart inhibit setting	OFF, 20 - 100% step 1	50%
Gn motor start current (I_{START})	1.5 - 10.0 x Iq step 0.1	3.0 x Iq
Gn motor stop current (I_{STOP})	0.05 - 0.20 x Iq step 0.05	0.10 x Iq
Gn stall withstand delay 1 (ts1)	1 - 250 secs step 1 sec, OFF	OFF
Gn stall withstand delay 2 (ts2)	1 - 250 secs step 1 sec, OFF	OFF
Gn CB fail time delay1	OFF, 0.01 - 20 sec step 0.01	OFF
Gn CB fail time delay2	OFF, 0.01 - 20 sec step 0.01	OFF

3 OVER/UNDER CURRENT PROTECTION MENU

SETTING	RANGE	DEFAULT
Gn Phase fault alarm setting (I_{HA})	OFF, 0.5 - 20 x I_n step 0.1	OFF
Gn Phase fault alarm delay (t_{HA})	0.00 - 1.00 sec step 0.01, 1.0 - 30.0 sec step 0.1	0.00 sec
Gn Phase fault trip setting (I_{HS})	OFF, 0.5 - 20 x I_n step 0.1	10 x I_n
Gn Phase fault trip delay (t_{HS})	0.00 - 1.00 sec step 0.01, 1.0 - 30.0 sec step 0.1	0.00 sec
Gn Earth fault alarm setting (I_{EA})	OFF, 0.005 - 1.000 x I_n step 0.005	OFF
Gn Earth fault alarm delay (t_{EA})	0.00 - 1.00 sec step 0.01, 1.0 - 30.0 sec step 0.1	0.00 sec
Gn Earth fault trip setting (I_{EF})	OFF, 0.005 - 1.000 x I_n step 0.005	0.1 x I_n
Gn Earth fault trip delay (t_{EF})	0.00 - 1.00 sec step 0.01, 10. - 30.0 sec step 0.1	0.00 sec
Gn Earth fault inhibit setting (I_{EI})	OFF, 4.0 - 10 x I_n step 0.1	OFF
Gn Undercurrent alarm setting (I_{UA})	OFF, 0.10 - 1.50 x I_n step 0.05	OFF
Gn Undercurrent alarm delay (t_{UA})	0.2 - 30.0 sec step 0.1	0.2 sec
Gn Undercurrent trip setting (I_{UC})	OFF, 0.10 - 1.50 x I_n step 0.05	OFF
Gn Undercurrent trip delay (t_{UC})	0.2 - 30.0 sec step 0.1	0.00 sec

4 PHASE UNBALANCE PROTECTION MENU

SETTING	RANGE	DEFAULT
Gn Phase unbalance type	Phase difference, NPS, OFF	OFF
Gn Phase difference setting	0.10 - 0.40 x I_q step 0.01	0.10 x I_q
Gn NPS setting	0.10 - 0.40 x I_q step 0.01	0.10 x I_q
Gn Unbalance time multiplier	0.025 - 2.000 step 0.025	1.000
Gn Unbalance min. Op. time	0.1 - 2.0 secs step 0.1	1.0 sec

5 NUMBER OF STARTS PROTECTION MENU

SETTING	RANGE	DEFAULT
Gn Max. number of starts	OFF, 1 - 20 step 1	OFF
Gn Max. starts period	1 - 60 mins step 1	15 mins
Gn Start inhibit delay	1 - 60 mins step 1	15 mins
Gn Min. time between starts	OFF, 1 - 60 mins step 1	OFF

6 TEMPERATURE PROTECTION MENU

SETTING	RANGE	DEFAULT
Temperature input type	RTD (100 Ω Pt), RTD (100 Ω Ni), RTD (120 Ω Ni), RTD (10 Ω Cu), RTD (Other), Thermistor (N ^o TC), Thermistor (PTC), None	None
Temp input fail protection	ON, OFF	OFF
Temp input 1 alarm setting	OFF, 0 - 250°C step 1 (1), or 100 - 350 Ω step 1 (2), or 100 - 1000 Ω step 10, 1100 - 30000 Ω step 100 (3)	OFF
Temp input 1 trip setting	As above	OFF
Temp input 1 gating	None, Temp Input 1, ... , Temp Input 8	None
...
Temp Input n alarm setting	OFF, 0 - 250°C step 1 (1), or 100 - 350 Ω step 1 (2), or 100 - 1000 Ω step 10, 1100 - 30000 Ω step 100 (3)	OFF

Temp input n trip setting	As above	OFF
Temp input n gating None,	Temp Input 1, .. , Temp Input 8	None
...
Temp Input 8 alarm setting,	OFF	OFF
	0 - 250°C step 1 (1),	
	or 100 - 350 Ω step 1 (2),	
	or 100 - 1000 Ω step 10, 1100 -	
	30000 Ω step 100 (3)	
Temp Input 8 trip setting	As above	OFF
Temp Input 8 gating None,	Temp Input 1, .. , Temp Input 8	None

Notes: (1) Settings applied where named RTD types are selected.
Settings applied where other RTD types are selected.
Settings applied where thermistors are selected.

7 OUTPUT CONFIGURATION MENU

SETTING	RANGE	DEFAULT
Gn Protection. healthy	RL1..RL7	RL1
Gn Thermal overload trip	RL1..RL7	RL2
Gn Thermal alarm capacity	RL1..RL7	RL4
Gn Thermal overload alarm	RL1..RL7	RL5
Gn Load increase alarm	RL1..RL7	RL6
Gn Restart inhibit	RL1..RL7	RL3
Gn Motor start alarm	RL1..RL7	RL7
Gn Stall delay 1 Trip	RL1..RL7	RL2
Gn Stall delay 2 Trip	RL1..RL7	RL2
Gn Phase fault alarm	RL1..RL7	None
Gn Phase fault trip	RL1..RL7	RL2
Gn Earth fault alarm	RL1..RL7	None
Gn Earth fault Trip	RL1..RL7	RL2
Gn Undercurrent alarm	RL1..RL7	None
Gn Undercurrent trip	RL1..RL7	RL2
Gn Phase Unbalance trip	RL1..RL7	RL2
Gn Status 1	RL1..RL7	None
Gn Status 2	RL1..RL7	None
Gn Status 3	RL1..RL7	None
Gn Status 4	RL1..RL7	None
Gn Status 5	RL1..RL7	None
Gn Status 6	RL1..RL7	None
Gn Status 7	RL1..RL7	None
Gn Status 8	RL1..RL7	None
Gn Status 9	RL1..RL7	None
Gn CB fail 1	RL1..RL7	None
Gn CB fail 2	RL1..RL7	None
Gn Temp input 1 alarm	RL1..RL7	None
Gn Temp input 1 trip	RL1..RL7	None
Gn Temp input 2 alarm	RL1..RL7	None
Gn Temp input 2 trip	RL1..RL7	None
Gn Temp input 3 alarm	RL1..RL7	None
Gn Temp input 3 trip	RL1..RL7	None
Gn Temp input 4 alarm	RL1..RL7	None
Gn Temp input 4	RL1..RL7	None
Gn Temp input 5 alarm	RL1..RL7	None
Gn Temp input 5 trip	RL1..RL7	None
Gn Temp input 6 alarm	RL1..RL7	None
Gn Temp input 6 trip	RL1..RL7	None
Gn Temp input 7 alarm	RL1..RL7	None
Gn Temp input 7 trip	RL1..RL7	None
Gn Temp input 8 alarm	RL1..RL7	None
Gn Temp input 8 trip	RL1..RL7	None
Gn Temp input fail alarm	RL1..RL7	None

Gn Trip counter alarm	RL1..RL7	None
Gn SI2 alarm	RL1..RL7	None
Gn start counter alarm	RL1..RL7	None
Gn Run-time hours alarm	RL1..RL7	None
Gn Hand	RL1..RL7	None

8 STATUS CONFIGURATION MENU

SETTING	RANGE	DEFAULT
Settings group select	S1..S9	None
Gn Inverted inputs	S1..S9	None
Gn Thermal protection inhibit	S1..S9	None
Gn Stall protection inhibit	S1..S9	None
Gn Phase fault inhibit	S1..S9	None
Gn Earth fault inhibit	S1..S9	None
Gn Unbalance inhibit	S1..S9	None
Gn Undercurrent inhibit	S1..S9	None
Gn No. of starts inhibit	S1..S9	None
Gn Temp protection inhibit	S1..S9	None
Gn Not accel.	S1..S9	None
Gn Trip circuit fail	S1..S9	None
Gn Alarm 1	S1..S9	None
Gn Alarm 2	S1..S9	None
Gn Alarm 3	S1..S9	None
Gn Alarm 4	S1..S9	None
Gn Alarm 5	S1..S9	None
Gn Alarm 6	S1..S9	None
Gn Alarm 7	S1..S9	None
Gn Alarm 8	S1..S9	None
Gn Alarm 9	S1..S9	None
Gn Waveform trig	S1..S9	None
Gn ΣI^2 update	S1..S9	None
Gn Clock sync	S1..S9	None
Gn Reset flag & outputs	S1..S9	None
Gn Status 1 P/U delay	0 - 2.00 sec step 10ms	0.02 sec
	2.10 sec - 20.00 sec step 100ms	
	21 sec - 300 sec step 1 sec	
	360 sec - 3600 sec step 60 sec	
	3900 sec - 14400 sec step 300 sec	
Gn Status 1 D/O delay	As above	0.00 sec
Gn Status 2 P/U delay	As above	0.02 sec
Gn Status 2 D/O delay	As above	0.00 sec
Gn Status 3 P/U delay	As above	0.02 sec
Gn Status 3 D/O delay	As above	0.00 sec
Gn Status 4 P/U delay	As above	0.02 sec
Gn Status 4 D/O delay	As above	0.00 sec
Gn Status 5 P/U delay	As above	0.02 sec
Gn Status 5 D/O delay	As above	0.00 sec
Gn Status 6 P/U delay	As above	0.02 sec
Gn Status 6 D/O delay	As above	0.00 sec
Gn Status 7 P/U delay	As above	0.02 sec
Gn Status 7 D/O delay	As above	0.00 sec
Gn Status 8 P/U delay	As above	0.02 sec
Gn Status 8 D/O delay	As above	0.00 sec
Gn Status 9 P/U delay	As above	0.02 sec
Gn Status 9 D/O delay	As above	0.00 sec

9 COMMUNICATIONS INTERFACE MENU

SETTING	RANGE	DEFAULT
Comms baud rate	75, 110, 150, 300, 600, 1200, 2400, 19200, 4800, 9600,	19200
Comms parity	NONE, EVEN	EVEN
Relay address	0 - 254	0
Line idle	LIGHT ON, LIGHT OFF	LIGHT OFF
Data echo	OFF, ON	OFF

10 DATA STORAGE MENU

SETTING	RANGE	DEFAULT
Gn Fault trigger	RL1..RL7	RL2
Gn Waveform configuration	1 x 10 sec, 10 x 1 sec	10 x 1
Gn Waveform trig	TRIP, START, STATUS, OFF	OFF
Gn Waveform pre-trigger	OFF, 10%-100% step 10%	10%
Clear all waveforms	NO, YES (Confirmation required)	NO
Clear all events	NO, YES (Confirmation required)	NO
Clear all faults	NO, YES (Confirmation required)	NO

11 MAINTENANCE MENU

SETTING	RANGE	DEFAULT
Thermal capacity reset	NO, YES (Confirmation required)	NO
Start protection reset	NO, YES (Confirmation required)	NO
Trip counter alarm	OFF, 1 - 999 step 1	OFF
Trip counter reset	NO, YES (Confirmation required)	NO
ΣI^2 Alarm	OFF, 10 - 100 step 1 MA2, 200 - 20000 step 100 MA2, 21000 - 100000 step 1000 MA2	OFF
ΣI^2 Reset		
Start counter alarm	OFF, 1 - 999 step 1 OFF	
Start counter reset	NO, YES (Confirmation required)	NO
Run-time hours alarm	OFF, 1 - 100 step 1 110 - 1000 step 10 1100 - 10000 step 100 11000 - 100000 step 1000	OFF
Run-time hours reset	NO, YES (Confirmation required)	NO
Maximum demand reset	NO, YES (Confirmation required)	NO
O/P relay test	Any output relay option	OFF

7SG17 Rho 3

Multifunction Protection Relays

Document Release History

This document is issue 2010/02. The list of revisions up to and including this issue is:

Pre release

2010/02	Document reformat due to rebrand

Software Revision History

--	--	--

The copyright and other intellectual property rights in this document, and in any model or article produced from it (and including any registered or unregistered design rights) are the property of Siemens Protection Devices Limited. No part of this document shall be reproduced or modified or stored in another form, in any data retrieval system, without the permission of Siemens Protection Devices Limited, nor shall any model or article be reproduced from this document unless Siemens Protection Devices Limited consent.

While the information and guidance given in this document is believed to be correct, no liability shall be accepted for any loss or damage caused by any error or omission, whether such error or omission is the result of negligence or any other cause. Any and all such liability is disclaimed.

Contents

- 1 INTRODUCTION 3
- 2 CONNECTION SPECIFICATION AND RELAY SETTINGS 3
 - 2.1 Recommended cable 3
 - 2.2 Transmission method 3
 - 2.3 Relay Settings 3
 - 2.4 Modems 4

1 INTRODUCTION

This document describes how to connect the IEC60870-5-103 compliant Informative Communication Interface to a control system or interrogating computer. To access the interface you will need appropriate software within the control system or, on the interrogating computer, for example, Reydisp Evolution. More detailed information regarding the communications interface can be found in a separate manual, the IEC60870-5-103 Communications Interface. This contains information about the format and content of the data available. It is available to developers writing software to interrogate the relays. Section 2 defines the connection medium as defined by IEC60870-5-103. Appendix A shows some typical communication connections. The Sigma range of products are available to connect to the fibre optic ports of the relays. Sigma 1 is a fibre optic hub with one system port and up to 29 ports for connecting to the relays. Sigma 3 is a fibre optic to dual RS232 interface. It has one fibre optic port for connection to the relay(s), and two electrical RS232 ports. The rear electrical port is intended for connection to a control system. The front port allows local access, for example, from a laptop PC. When a device is connected to the front port the rear is overridden. Sigma 4 is a portable fibre optic to RS232 conversion unit.

2 CONNECTION SPECIFICATION AND RELAY SETTINGS

2.1 Recommended cable

Selection of fibre optic cable is critical. Fibres should be terminated with 9mm SMA connectors. The recommended type is 200µm Plastic Coated Silica (PCS). This will allow a maximum transmission distance of 100m between Argus relays. This will also be the maximum distance between the ring network and the fibre to RS232 converter. Alternatively, 1mm polymer cable may be used to reduce cost. This will provide transmission distances of up to 43m between relays. Note that the distance from the transmit output of the RS232 / fibre optic converter to the receive input of the first Argus relay should not be more than 6m. The distance from the transmit output of the last Argus to the receive input of the converter may be up to 43m. No other types of cable are suitable for use with Argus relays.

2.2 Transmission method

Half Duplex serial asynchronous transmission. In IEC60870-5-103 the line idle state is defined as **Light On**. This can alternatively be selected as **Light Off** in the Communications Interface menu of the settings list if required for use with alternate hardware (See Section 2.3.4).

2.3 Relay Settings

2.3.1 Baud Rate

Rates of **19200, 9600, 4800, 2400, 1200, 600, 300, 150, 110** and **75** bits per second (BPS) are available. Only **19200** and **9600** BPS are defined in IEC60870-5-103. The additional rates are provided for local or modem communications. Default 19200.

2.3.2 Parity setting

IEC60870-5-103 defines the method of transmission as using **Even** Parity. However, in some instances an alternative may be required. This option allows the setting of parity to **None**. Default Even.

2.3.3 Address setting

The address of the relay must be set to a value between 1 and 254 inclusive before communication can take place. Setting the address to zero disables communications to the relay. All relays in an optical ring, as illustrated in figure 3, must have a unique address. Address 255 is reserved as a global broadcast address. Default zero.

2.3.4 Line idle setting

The line idle setting must be set to be compatible with the device connected to the relay IEC60870-5-103 defines a line idle state of **Light On**. The Sigma range of products for connecting to the fibre-optic ports on the relays support either **Light ON** or **OFF**. All sigma units are supplied Light Off. Sigma 1 has internal DIL switches to set the condition for each fibre optic channel, Sigma 3 and 4 have an internal jumper to set the state of their fibre optic channel. Refer to diagrams in appendix A. The setting allows you to switch the line idle state to that suitable for your hardware. The following table shows the line-idle settings for the Honeywell type HFM5500 fibre-optic to RS232 convertors. Default off.

Device	Line Idle Setting Required
HFM5500-AAM, HFM5500-AAF	Light Off
HFM5500-BAM, HFM5500-BAF	Light On

2.3.5 Connection method

Communication networks can be connected as Star, figure 4, or Optical Ring, figure 3, configuration. The Optical Ring architecture requires data to be passed from one relay to the next. When using this method all relays in the ring must have Data Echo = **ON** selected in the Communications Interface menu of the settings list. Otherwise this setting is to be Data Echo = **OFF**.

Note, if the address setting is zero Data Echo = ON will still allow echo data. Default off.

2.4 Modems

The communications interface has been designed to allow data transfer over a telephone system via modems. For more information regarding using and installing modems refer to document 434/TIR/7 Remote Communication to Argus Relays.

APPENDIX A – METHODS OF COMMUNICATION CONNECTION

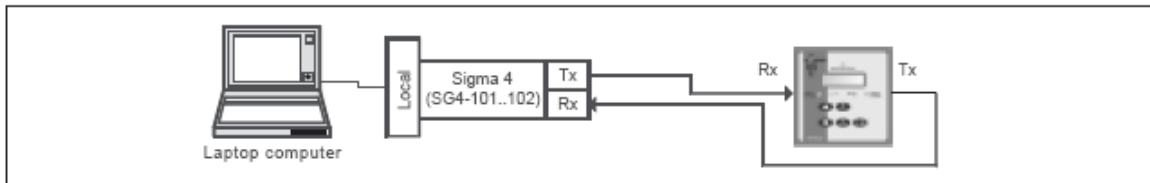

Figure 1 - Basic communications configuration (Local)

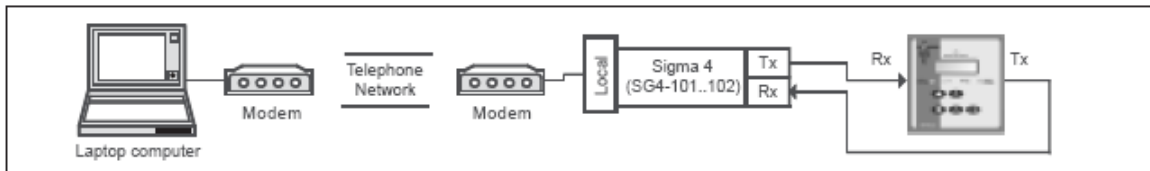

Figure 2 - Basic communications configuration (Remote)

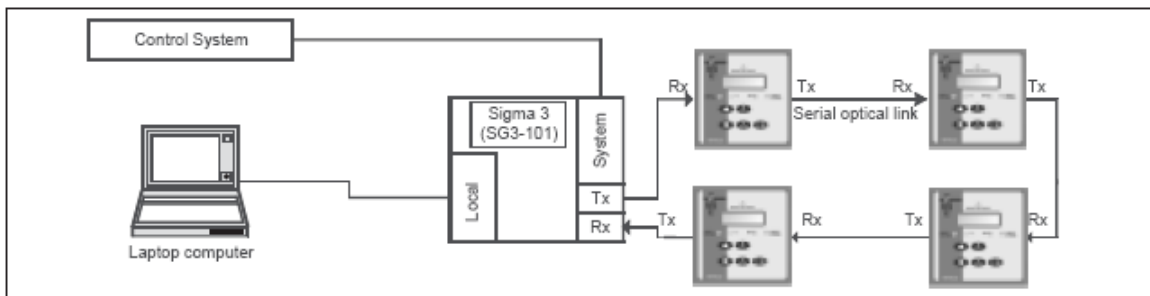

Figure 3 - Communication using Reyrolle Sigma 3 in optical ring configuration

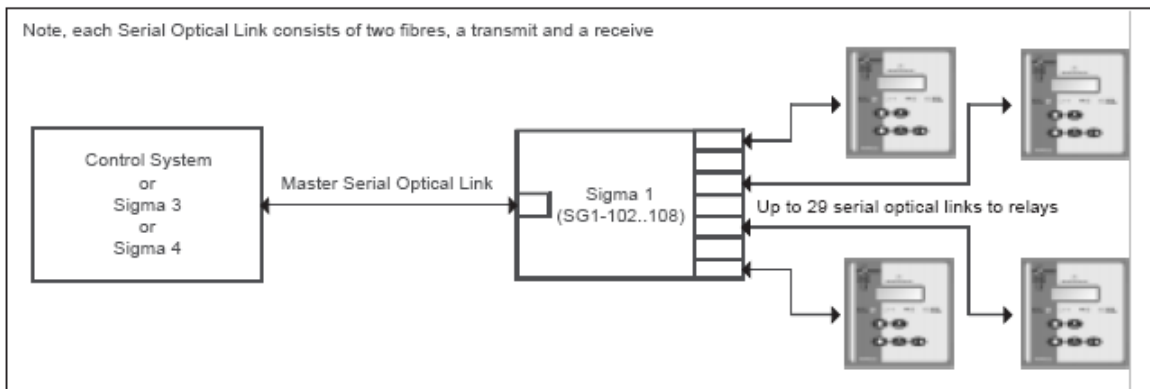

Figure 4 - Communication using Reyrolle Sigma 1 in star configuration

7SG17 Rho 3

Multifunction Protection Relays

Document Release History

This document is issue 2010/02. The list of revisions up to and including this issue is:

Pre release

2010/02	Document reformat due to rebrand

Software Revision History

--	--	--

The copyright and other intellectual property rights in this document, and in any model or article produced from it (and including any registered or unregistered design rights) are the property of Siemens Protection Devices Limited. No part of this document shall be reproduced or modified or stored in another form, in any data retrieval system, without the permission of Siemens Protection Devices Limited, nor shall any model or article be reproduced from this document unless Siemens Protection Devices Limited consent.

While the information and guidance given in this document is believed to be correct, no liability shall be accepted for any loss or damage caused by any error or omission, whether such error or omission is the result of negligence or any other cause. Any and all such liability is disclaimed.

Contents

1.	SELECTION OF PROTECTION FUNCTIONS	3
2.	MULTIFUNCTION APPLICATIONS.....	3
2.1.	C.T. Ratio	3
2.2.	C.T Ratio Thermal Overload Setting.....	4
2.3.	NPS weighting factors	4
2.4.	Heating time constant, τ_h	4
2.5.	Starting time constant, τ_s	4
2.6.	Cooling time constant, τ_c	6
2.7.	Hot/cold curve ratio (hot spot weighting)	6
2.8.	Thermal capacity alarm setting.....	6
2.9.	Load increase alarm setting τ_{s1}	6
2.10.	Thermal restart inhibit setting.....	6
2.11.	Motor start current (ISTART)	7
2.12.	Motor stop current.....	7
2.13.	Stall and locked rotor protection (τ_{s1} and τ_{s2} settings)	7
2.14.	Circuit breaker fail protection (time delays 1 and 2).....	7
3.	OVER/UNDER CURRENT PROTECTION	8
4.	PHASE UNBALANCE PROTECTION.....	9
5.	NUMBER OF STARTS PROTECTION	9
6.	OPTIONAL TEMPERATURE INPUTS.....	9
7.	OTHER FEATURES	10

1. SELECTION OF PROTECTION FUNCTIONS

The 7SG17 relays incorporate a number of protection functions for the protection of induction and synchronous motors and may be scaled to suit the particular application. When selecting the relay and functions some general considerations are as follows:-

- Motor load e.g. pump, fan, compressor, conveyor etc.
- Frequency of operation
- Whether the motor incorporates RTD devices to monitor winding and bearing temperatures
- Whether the motor incorporates a speed switch
- Motor rating

When applying the relay, individual protection functions may be enabled as required and are defined in detail in the Description of Operation.

2. MULTIFUNCTION APPLICATIONS

As a typical example, consider the protection of a 4 pole induction motor with the following parameters:-

Rated voltage:	6.6KV
Rated output power:	800KW
Power factor:	0.85
Efficiency :	95.5%
Starting:	Direct on line
Controlled by:	Vacuum circuit breakers
Locked rotor current:	5 x full load
Run-up time:	4 secs
Safe stall times:	
Starting (cold):	11 secs
Running (hot):	7 secs
Permitted number of Starts per period:	2 per hour (hot)

$$\text{Input power} = \frac{\text{Output}}{P.F. \times \text{efficiency}} = \frac{800}{0.85 \times 0.955} = 985 \text{KVA}$$

$$\text{Full load current} = \frac{\text{KVA}}{\sqrt{3} \text{ kV}} = \frac{985}{1.73 \times 6.6} = 86.2 \text{ Amps}$$

2.1.C.T. Ratio

The C.T. ratio should be chosen as equal to or the next standard above the motor full load rating in this case choose 100 amp primary. The secondary could be either 1 or 5 amp. The modern tendency is to standardise on 1 amp, so choose a 100/1 ratio.

The relay thermal full load setting is:

$$\frac{\text{Motor FLC}}{\text{CT Ratio}} = \frac{86.2 \times 1}{100} = 0.86 \text{ A}$$

2.2.C.T Ratio Thermal Overload Setting

It is usual to choose a thermal overload setting above which the relay starts timing out, of 105%. This allows full utilisation of the output rating of the motor. In this case, this equates to $1.05 \times 0.86 = 0.903$. As the C.T. secondary is 1 amp the thermal overload (I_{θ}) should be set to 0.90.

Alternatively, if it is known that the rating of the motor is well in excess of the requirements of the drive, and the motor load current is therefore less than the motor rated current, a setting equal to or less than 1.0 can be employed. The thermal overload is then being employed to protect the drive and over protects the motor.

2.3.NPS weighting factors

The relay computes the positive and negative sequence components from the three phase input line currents. These are used to generate an equivalent thermal current I_{eq} which is calculated from the equation.

$$I_{eq} = \sqrt{I_1^2 + KI_2^2}$$

Where:

I_1 = Positive phase sequence current

I_2 = Negative phase sequence current

K = NPS weighting factor

K is settable on the relay from 0 to 10. If the motor supplier or manufacturer provides data giving the machine negative sequence withstand (NPS weighting factor), this figure should be used. If no figure is available, it is recommended that K be set to 4. Should this setting give nuisance tripping in service, the stored records should be studied and the motor manufacturer consulted before decreasing the weighting factor.

Negative sequence currents give rise to additional rotor heating, they produce a substantial rotor current at approximately twice system frequency. At this frequency, skin effects in rotor bars can cause significant rotor heating. Usually thermal limit curves supplied by machine manufacturers assume positive sequence currents only from a perfectly balanced supply. The relays are settable to give complete motor protection under all supply conditions.

2.4.Heating time constant, τ_h

The relay heating time constant τ_h is settable from 0.5 to 100 minutes in 0.5 steps, figure 1 shows the family of curves. Using the example of the motor parameters quoted under item 2 above and reading values from Figure 1:-

At a locked rotor current of 5 x FLC (which is about the starting current) and a run-up time of 4 seconds and allowing two consecutive starts i.e. 8 seconds total run-up time, the τ_h value from figure 1 is just over 3 minutes. As the safe stall time from cold is 11 seconds, the τ_h value could be set to 5. The stall time from hot, i.e. 7 seconds gives a τ_h value of 3. If this lower value of 3 is chosen, there is the possibility of nuisance tripping after the motor has been in service for some time with longer run-up times and higher currents. It would be better to select the value of 5 which allows two starts in quick succession. Of course, if the actual τ_h heating time constant of the motor is given by the manufacturer, then this figure could be set on the relay.

2.5.Starting time constant, τ_s

When a motor is running at full design speed, the airflow and ventilation is designed to give optimum cooling. On starting, the current is nearly the stall value but the ventilation is reduced. If this time constant is known, it can be set on the relay. If not, then set the time constant (settable 0.5 to 1.5 of the heating time constant τ_h) to 1.0, i.e. the same as τ_h . The time constant switches from τ_h to τ_s as current levels above the set value of I_{START} . When τ_s is set below $1.0 \times I_{\theta}$, this feature assists in ensuring that a stall on start up does not exceed the motor withstand time. However where the stall withstand time (e.g. from 'hot') is less than the run-up time it is still necessary to provide a tachometric speed switch on the rotor shaft as described previously. The time constant switches from τ_h to τ_s at current levels above the set valve of I_{START} .

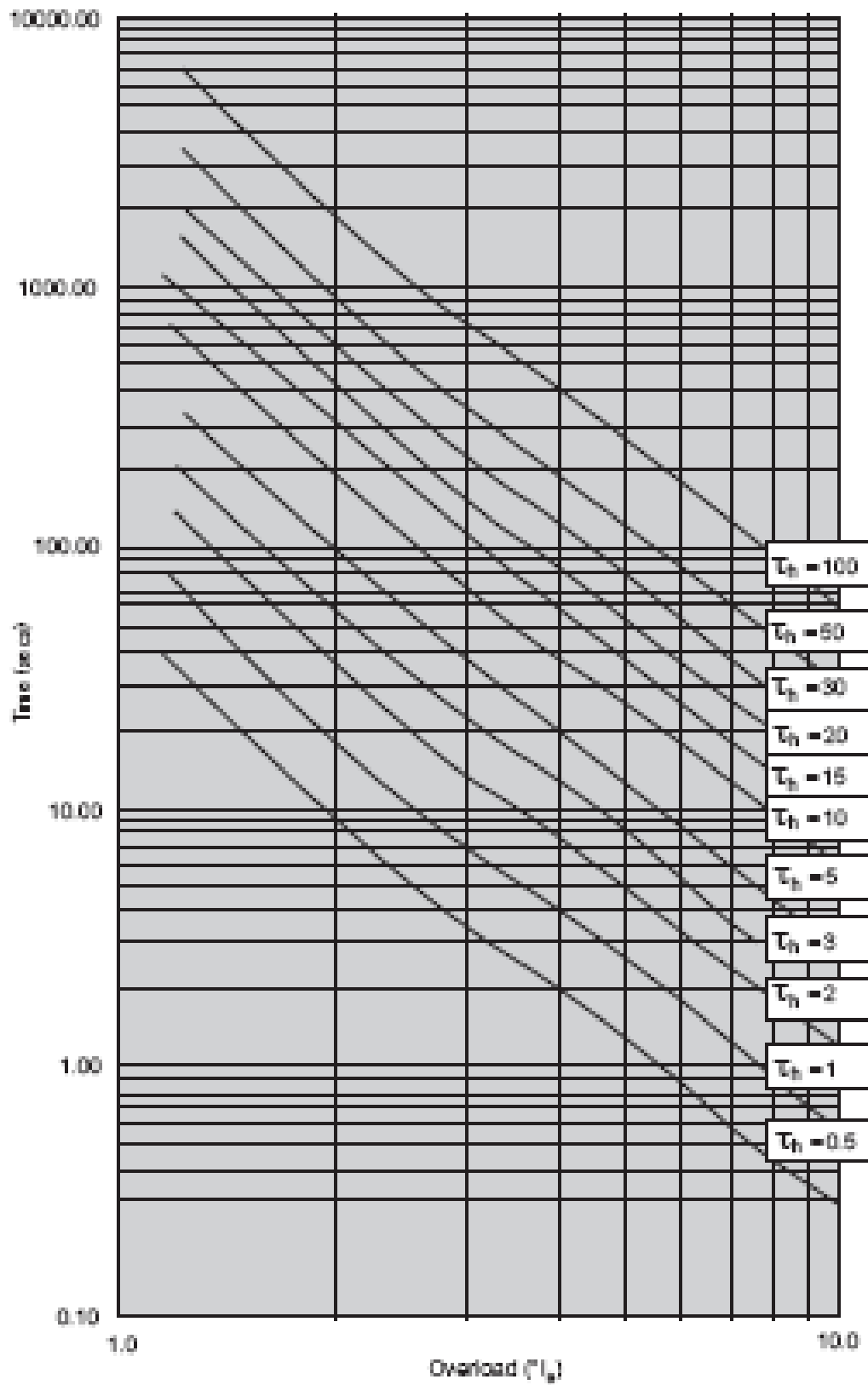

Figure 1 - Thermal overload (cold) characteristics

2.6. Cooling time constant, τ_c

When a motor is switched off the rotor decelerates and eventually stops. During the run-down state and standstill state the motor windings will cool down but they are likely to have a different time constant for cooling than for heating up during running. This is because during the start-up and running state there is forced cooling experienced by the windings due to the rotor movement.

The cooling time constant of the motor is therefore always longer than the heating time constant for running. The factor of τ_c/τ_h is not specified by the motor manufacturer very often. Typical factors are 5 to 10 x, however for large motors which are totally enclosed and also ones that normally rely heavily on forced cooling due to motion of the rotor, the factor can be as high as 60x.

The net result of choosing a high value for τ_c is that it may not be possible to start the motor immediately after a shut down.

In this example, the cooling time constant has not been specified either as a time constant or as a multiple of its heating time constant. We will therefore choose 10x, which is the default.

2.7. Hot/cold curve ratio (hot spot weighting)

The relay allows adjustment of the Hot/Cold curve operating time ratio. This allows a weighting factor for motor winding hot spots to be applied. Motors with onerous hot spots are overdesigned for normal load and by selecting a high value of H/C it allows advantage to be taken of the overdesign for overload, i.e. longer operating time. Selecting the Hot/Cold ratio (H/C) to 100% (i.e. a high weighting factor) results in the relay indicating 100% thermal capacity being available when the motor has been running at full load for a sufficiently long time to reach steady after a motor-switch on. The hot and cold operating time curves are the same.

A low weighting factor would be 5%. Switching H/C to OFF is equivalent to H/C = 0. In this case, when operating at full load, the relay would indicate little thermal capacity available, e.g. 100% used. The hot operating time curve is then much faster than the cold.

An indication of the motor hot spot characteristic is the ratio of hot stall withstand to the cold withstand, τ_h/τ_c . With no hot spots (e.g. a cable) this ratio would be = 1.

In our example $\tau_h/\tau_c = 7/11 = 0.64$. The nearest H/C setting i.e. 65% should be applied to the relay. Note that at steady state full load current the relay will stabilize at 'Thermal Capacity Used' of 35% with this setting applied.

2.8. Thermal capacity alarm setting

This setting is expressed as a percentage of the thermal capacity set as above. It is settable 50 to 100% of the set capacity and gives an instantaneous alarm output if its setting is exceeded. Typically this would be set to 95%.hermal model

2.9. Load increase alarm setting $ts1$

This alarm is available to provide warning of a sudden increase of load. The alarm level is set as a multiple of the thermal overload setting (see 2.2). The range is 0.5 to 1.0 x I_0 and a sudden step increase above the set value will initiate the alarm if set.

2.10. Thermal restart inhibit setting

This feature is included to help prevent tripping of the motor during start if there is insufficient thermal capacity to satisfactorily complete the start operation. The calculation of this value is complex and requires motor parameter details not usually available. The practical setting recommended is to initially set this feature to 50%. During commissioning, before starting the protected motor, check the thermal state at the motor by accessing the "Thermal Capacity Used" display and note the value. The motor should then be started with its normal load and, when up to speed the "Thermal Capacity Used" display again checked. The difference between these two values indicates the magnitude of thermal capacity used to start. This amount must always be available before a restart is permitted. For safety, this figure should be multiplied by 1.25. For example, if 20% of capacity is used during starting, then 20% x 1.25 = 25%, and the Thermal Restart Inhibit Setting should be 75%.

2.11. Motor start current (ISTART)

The motor starting current is usually taken to be the same as the locked rotor current but the setting of ISTART should be less than this value. For the example given in 2.0, the value of 4 should be chosen.

2.12. Motor stop current

This current is the value at or below which the motor is considered to be stopped. It is usually set at 10%.

2.13. Stall and locked rotor protection (ts1 and ts2 settings)

The fundamentals of this protection feature are explained in the Description of Operation, 2.2. In the example being considered, the run-up time is 4 seconds and the safe stall time is 11 seconds. In this case the thermal characteristic gives sufficient protection for normal starting and a stalled motor condition can be detected by current/time grading. The time ts1 should be set to be longer than the run-up time and less than the safe stall time, in the example a time setting of 5 seconds should be chosen. If the motor starting time is equal to or exceeds the stall withstand time, it is necessary to have a tachometric 'zero speed' switch mounted on the rotor shaft. A voltage signal must be connected via this switch to a status input which is programmed to the 'No Accel' function in the status configuration menu. This effectively brings the timer ts2 into service. The switch is closed with a stalled motor and if the current exceeds the starting current set (I_{START}) then the timer ts2 will time out and will give a trip signal after its set time lag. On a healthy start, the switch will open thus stopping the timer. In this configuration, ts1, can be used to provide protection against excessive start time.

2.14. Circuit breaker fail protection (time delays 1 and 2)

The relay incorporates a two stage circuit breaker fail feature. If a designated trip relay operates and the circuit breaker fails to open, the protection algorithm continues to run for as long as current continues to flow. This combination of conditions is programmed to start a definite time lag feature designated "CB Fail 1". This function can be programmed to energise an output relay when the C.B. fail time delay is completed. The contacts of this are wired to carry out a repeat trip or to trip another circuit breaker typically an incoming breaker. At the same time operation of this timer starts a second time lag feature designated "CB Fail 2" and if the trip outputs already initiated do not stop the current flow through the relay, another relay can be programmed through the output matrix to trip a further breaker eg. a bus section circuit breaker. The timers should be set to operate in 50mSecs plus the longest C.B. tripping time. The circuit breaker fail feature can also be used to implement a multi-stage tripping scheme.

3. OVER/UNDER CURRENT PROTECTION

These protection settings relate to major faults, e.g. short circuits and motor drive shaft failures.

3.1. Phase fault alarm setting (IHA) and time delay (tHA)

If it is necessary to monitor the instantaneous current of the motor, this feature can be employed to effectively act as a contact making ammeter. The time lag feature can be used to prevent operation for current surges.

3.2. Phase fault trip setting (IHS) and time delay (tHS)

This protection feature is supplied to detect and protect against phase faults occurring on the circuit between the controlling device and the motor, for example a fault in the terminal box. Note that if the motor controlling device (contactor or circuit breaker) is not rated to interrupt fault current, this feature should be turned off. Alternatively, this feature can be mapped to a separate output relay with contacts connected to trip a suitably rated upstream device. If this feature is selected, the current setting should be greater than motor starting current. To prevent operation for very short high value starting surges such as may occur in charging the cable between the switching device and the motor, or when power factor correction capacitors are installed, a time delay can be inserted. The delay should be fine tuned to the application such that it operates to isolate faults with a minimum time delay but rides through operational disturbances.

3.3. Earth fault alarm setting IEA and time delay (tEA)

These settings can be selected if required as in 3.1.

3.4. Earth fault trip setting (IEF) and time delay (tEF)

This feature protects against earth (ground) faults occurring on the protected circuits. Ideally, the earth fault input should be energised from a core balance C.T. In this case the time delay can be set to zero without risk of mal-trip at motor switch on. If the earth fault input is energised by the residually connected line C.T.'s a time delay must be introduced to overcome the transient neutral current that often occurs on motor starting. The actual time setting depends on the current sensitivity selected, the motor starting time and the C.T. characteristics. Typical times are about 0.3 sec but the value should be set as low as possible consistent with reliability and avoidance of nuisance tripping. Alternatively, it may be possible to use a stabilizing resistor to ensure stable, instantaneous tripping. Refer to our 'Application Guide for selection of stabilising resistor when employing residually connected earth fault input'.

3.5. Earth fault inhibit setting (IEI)

This feature is included to block operation of the earth fault device if the fault current is greater than the breaking capacity of a controlling contactor. If this is used, then the earth fault alarm contact can be used to issue a back-trip signal to an upstream circuit breaker.

3.6. Undercurrent protection

An undercurrent element protects against the no-load condition by measuring the RMS current in each phase. Alarm and trip outputs are provided. To prevent spurious trip operations when the relay is first energised or when a motor is disconnected, the undercurrent protection does not operate for currents below the motor stopped threshold I_{STOP} . This protection is typically applied if the protected motor drives a pump cooled by the liquid it pumps. In this case, loss of load may cause pump overheating. If the motor loading should never fall below 0.75 full load current, in the example given in 2.0, the undercurrent trip should be set at $0.7I_{FLC} = 0.7 \times 0.86 = 0.60$ and the alarm set at $0.75 I_{FLC} = 0.75 \times 0.86 = 0.65$. Time delays should be set to as low a value as possible - typically 1 sec. An undercurrent alarm is given if current falls below the undercurrent alarm setting I_{UA} in any phase (but not below I_{STOP}) for longer than the definite time delay t_{UA} . The undercurrent feature can be disabled. The various threshold setting ranges overlap. The user is responsible for ensuring that the motor stopped threshold is set below the alarm and trip levels, otherwise this protection feature will not operate.

To ensure correct discrimination between the motor stopped and loss of load conditions, the undercurrent protection has a minimum operate time of 200ms.

4. PHASE UNBALANCE PROTECTION

Fluctuations of current unbalance levels are typically caused by variations in the phase supply voltages. Note that a 1% voltage unbalance typically translates into a 6% current unbalance. In order to prevent nuisance trips, the pick-up level should not be set too low but, as current unbalance can cause serious rotor overheating the motor manufacturers recommendation as to the maximum allowable unbalance or negative sequence should be set. As short term unbalances occur, a reasonable time delay should be selected.

Separate protection is available for the conditions of phase unbalance, loss of phase and reverse phase sequence. This feature can be programmed to operate either as phase difference protection or as negative phase sequence overcurrent protection. It can also be disabled altogether. The Alternatives of Phase Difference and Negative Sequence Overcurrent Protection are given in section 2.5 of the Description of Operation.

5. NUMBER OF STARTS PROTECTION

This feature permits a limit to be set on the number of times which the motor may be started within a specified time interval. Settings are provided to allow the user to select the maximum permissible number of starts and the time interval within which these starts may occur. Once the maximum permissible number of starts have occurred within the defined period then starting is inhibited for the duration of the start inhibit delay setting.

Typically, two or three consecutive starts are permitted for a large motor which means that the motor and driven machine have to slow down to a stop before a start is attempted. The coasting down time may be many minutes and the time interval should reflect this. The motor manufacturer should be consulted, and if the start duty is severe then the manufacturer may impose a deliberate waiting time between starts, this must be set on the relay.

A start is detected by the relay when the current rises from zero to exceed the start current setting I_{START} already described in the section on stall and locked rotor protection. A restart is inhibited by the same output contact used for the thermal restart inhibit feature. The restart inhibit output is only energised after the motor has stopped (i.e. current falls below I_{STOP}) so that the start sequence in progress is not interrupted.

A further setting is provided to determine the minimum permissible time between two consecutive starts.

A 'Start Protection Reset' command is available in the 'Maintenance Menu' which allows the user to reset both the number of starts and the minimum time between starts features. This feature, if set, will prevent the operator from jogging the motor. Jogging is defined as multiple starts and stops that are performed in quick succession.

6. OPTIONAL TEMPERATURE INPUTS

An optional version of the relay incorporates 8 temperature inputs to allow direct temperature monitoring of parts of the motor. The inputs are user programmable to accommodate resistance temperature detectors (RTDs) and thermistors. Different types of inputs cannot be mixed. Each input may be independently programmed to provide alarm and trip thresholds giving instantaneous outputs. These can all be de-activated by programming the settings to OFF.

Temperature inputs are usually incorporated in the motor by the manufacturer and the types and characteristics should be obtained from the supplier.

6.1 RTD Inputs

RTD inputs may be selected from a number of types, namely 100 Ω Platinum (standard type DIN 43760), 100 Ω Nickel, 120 Ω Nickel, 10 Ω Copper or 'other'. The named types have reasonably linear, known characteristics and the measured resistances are converted into temperatures between -50°C and +250°C and displayed. Alarm and trip settings are also programmed in terms of temperature. If the 'other' type is selected then measurements and settings are displayed as resistances up to 350 Ω .

6.2 Thermistor Inputs

Thermistor inputs may be selected as either positive or negative temperature coefficient types (PTC or NTC).

Thermistors are available with a wide range of generally non-linear characteristics and so settings and displays are given in terms of resistance. Values between 100 Ω and 30k Ω are accommodated. For PTC type devices, the protection operates when resistance is measured above the applied setting. For NTC type devices, the protection operates when resistance is measured below the applied setting.

6.3 Detector failure protection

Each active temperature input can be monitored for short circuit and open circuit failure. A temperature input fail alarm output is generated by a failure condition and the failed input is identified in the Instruments Menu. No trip or alarm output is given by a failed input. This feature can be disabled.

6.4 Detector gating

Further security is provided by allowing each temperature input to be AND gated with any other input. If this feature is selected then no trip will be issued unless both gated inputs detect temperature (or resistance) above the trip setting. The temperature input alarm outputs are not subject to gating.

7. OTHER FEATURES

7.1 Trip circuit supervision

Based on the Electricity Association standard schemes referenced H6, a status input on the relay can be used to supervise the trip circuit with the associated circuit breaker open or closed. A low value of d.c. current is passed through the entire trip circuit to monitor the trip coil, its auxiliary switch, the CB secondary isolating contacts and the relevant wiring. If monitoring current flow ceases, the energised status input drops off and if it is user programmed to operate one of the output relays, this relay gives a contact output to signal trip circuit fail. In addition, the LCD display on the Rho relay and any PC connected via the fibre optic communication port and running Reydisp software can be programmed to indicate "Trip CCT Fail".

To avoid giving spurious alarm messages while the circuit breaker is operating, the status input should be programmed to have a 500mSec drop-off delay. The schemes are shown in figure 1.

Figure 1 - Rho 3 - Trip circuit supervision

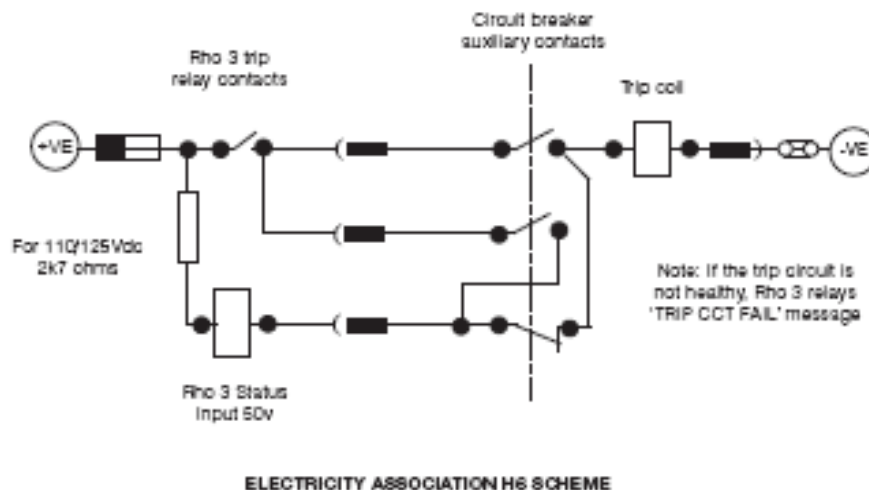

7SG17 Rho 3

Multifunction Protection Relays

Document Release History

This document is issue 2010/02. The list of revisions up to and including this issue is:

Pre release

2010/02	Document reformat due to rebrand

Software Revision History

--	--	--

The copyright and other intellectual property rights in this document, and in any model or article produced from it (and including any registered or unregistered design rights) are the property of Siemens Protection Devices Limited. No part of this document shall be reproduced or modified or stored in another form, in any data retrieval system, without the permission of Siemens Protection Devices Limited, nor shall any model or article be reproduced from this document unless Siemens Protection Devices Limited consent.

While the information and guidance given in this document is believed to be correct, no liability shall be accepted for any loss or damage caused by any error or omission, whether such error or omission is the result of negligence or any other cause. Any and all such liability is disclaimed.

Table of Contents

Table of Contents	2
1. UNPACKING, STORAGE AND HANDLING.....	3
2 RECOMMENDED MOUNTING POSITION	3
3 RELAY DIMENSIONS	3
4 FIXINGS	3
4.2 Panel Fixing Screws	3
4.3 Communications	4
5 ANCILLARY EQUIPMENT	4

1. UNPACKING, STORAGE AND HANDLING

On receipt, remove the relay from the container in which it was received and inspect it for obvious damage. It is recommended that the relay is not removed from the case. To prevent the possible ingress of dirt, the sealed polythene bag should not be opened until the relay is to be used. If damage has been sustained a claim should immediately be made against the carrier, also inform Reyrolle Protection and the nearest Reyrolle agent. When not required for immediate use, the relay should be returned to its original carton and stored in a clean, dry place. The relay contains static sensitive devices, these devices are susceptible to damage due to static discharge and for this reason it is essential that the correct handling procedure is followed. The relay's electronic circuits are protected from damage by static discharge when the relay is housed in its case. When it has been withdrawn from the case, static handling procedures should be observed.

- Before removing the relay from its case the operator must first ensure that he is at the same potential as the relay by touching the case
- The relay must not be handled by any of the relay terminals on the rear of the chassis.
- Relays must be packed for transport in an antistatic container
- Ensure that anyone else handling the relays is at the same potential

As there are no user serviceable parts in the relay, then there should be no requirement to remove any modules from the chassis.

If any modules have been removed or tampered with, then the guarantee will be invalidated. Reyrolle Protection reserve the right to charge for any

2 RECOMMENDED MOUNTING POSITION

The relay uses a liquid display (LCD) which is used in programming and or operation. The LCD has a viewing angle of $\pm 70^\circ$ and is back lit. However, the best viewing position is at eye level, and this is particularly important when using the built-in instrumentation features.

The relay should be mounted on the circuit breaker or panel to allow the operator the best access to the relay functions.

3 RELAY DIMENSIONS

The relay is supplied in modular case range size 6 or 8. The larger case is used with RTD inputs. Diagrams are provided elsewhere in this manual.

4 FIXINGS

4.1 Crimps

Amp Pidg or Plasti Grip Funnel entry ring tongue.

Size	AMP Ref	Reyrolle Ref
0.25-1.6mm ²	342103	2106E11802
1.0-2.6mm ²	151758	2106E11264

4.2 Panel Fixing Screws

Kit - 2995G10046 comprising:

- g Screw M4 X10TT
2106F14010 - 4 off
- g Lock washes
2104F70040 - 4 off

- g Nut M4
2103F11040 - 4 off

4.3 Communications

9mm SMA fibre optic connections - 2 per relay (refer to section 4 - Communications Interface).

5 ANCILLARY EQUIPMENT

The relay can be interrogated locally or remotely by making connection to the fibre optic terminals on the rear of the relay. For local interrogation a portable PC with a fibre to RS232 modem is required. The PC must be capable of running Microsoft Windows Ver 3.1 or greater, and it must have a standard RS232 port in order to drive the modem. For remote communications more specialised equipment is required. See the section on communications for further information.

7SG17 Rho 3

Multifunction Protection Relays

Document Release History

This document is issue 2010/02. The list of revisions up to and including this issue is:

Pre release

2010/02	Document reformat due to rebrand

Software Revision History

--	--	--

The copyright and other intellectual property rights in this document, and in any model or article produced from it (and including any registered or unregistered design rights) are the property of Siemens Protection Devices Limited. No part of this document shall be reproduced or modified or stored in another form, in any data retrieval system, without the permission of Siemens Protection Devices Limited, nor shall any model or article be reproduced from this document unless Siemens Protection Devices Limited consent.

While the information and guidance given in this document is believed to be correct, no liability shall be accepted for any loss or damage caused by any error or omission, whether such error or omission is the result of negligence or any other cause. Any and all such liability is disclaimed.

Table of Contents

1.	REQUIRED TEST EQUIPMENT	3
2.	INSPECTION	3
3.	APPLYING SETTINGS	3
4.	PRECAUTIONS.....	3
5.	TESTS	3
5.1.	Insulation	3
5.2.	Secondary injection.....	4
5.3.	Pickup and reset	4
5.4.	Thermal characteristics	4
5.5.	Over/under current protection	5
5.6.	Phase unbalance protection	5
5.7.	Number of starts	5
5.8.	Temperature protection	5
5.9.	Output and status configuration	5
5.10.	Circuit breaker fail	6

1. REQUIRED TEST EQUIPMENT

- 500V Insulation resistance test set
- Variable secondary injection current source rated 10A or greater
- Time interval meter
- Primary injection equipment
- A d.c. supply with nominal voltage within the working range of the relay's d.c. auxiliary supply rating
- A d.c. supply with nominal voltage within the working range of the relay's d.c. input rating Additional equipment for testing the communications channel:
 - Portable PC with the fibre optic modem connections
 - Portable printer to operate from the above PC

2. INSPECTION

Ensure that all connections are tight and in accordance with the relay wiring diagram and the scheme diagram. Check the relay is correctly programmed and the relay is fully inserted into the case. Refer to the Description of Operation for programming the relay.

3. APPLYING SETTINGS

The relay settings for the particular application should be applied before any secondary testing occurs. If they are not available then the relay has default settings which can be used for pre-commissioning tests. Note the tripping and alarm contacts must be programmed correctly before any scheme tests are carried out. See the Relay Setting section of this manual for the default settings. Rho 3 relays feature eight alternative setting groups. In applications where more than one setting group is to be used then it may be necessary to test the relay in more than one configuration. When using setting groups it is important to remember that the relay need not necessarily be operating according to the settings which are currently being displayed. There is an 'active setting group' on which the relay operates and an 'edit/view setting group' which is visible on the display and which can be altered. This allows the setting in one group to be altered while protection continues to operate on a different unaffected group. The 'active setting group' and the 'edit setting group' are selected in the 'System Configuration Menu'. Elsewhere in the setting menu system, those settings which can be altered or different groups are indicated by the symbols G1, G2 etc. in the top left of the display. Other settings are common to all groups.

4. PRECAUTIONS

Before testing commences the equipment should be isolated from the current transformers and the CT's short circuited in line with the local site procedures. The tripping and alarm circuits should also be isolated where practical.

Ensure that the correct d.c. auxiliary voltage is applied to the circuit. See the relevant scheme diagrams for the relay connections.

5. TESTS

5.1. Insulation

Connect together all of the C.T. terminals and measure the insulation resistance between these terminals and all of the other relay terminals connected together and to earth. Connect together the terminals of the DC auxiliary supply circuit and measure the insulation resistance between these terminals and all of the other relay terminals connected together and to earth. Connect together the terminals of the DC status input circuits and measure the insulation resistance between these terminals and all of the other relay terminals connected together and to earth. Connect together the terminals of the output relay circuits and measure the insulation resistance between these terminals and all of the other relay terminals connected together and to earth. Satisfactory values for the various readings depend upon the amount of wiring concerned. Where considerable multi-core wiring is involved a reading of 2.5 to 3.0 megohms can be considered satisfactory. For short lengths of wiring higher values can be expected. A value of 1.0 megohm should not be considered satisfactory and should be investigated. Remove temporary connections.

5.2. Secondary injection

Select the required relay configuration and settings for the application. Note that the Rho 3 may be connected as either 1A or a 5A rated device. The User should check this before commencing secondary testing.

5.3. Pickup and reset

These tests check the accuracy and soundness of the relay's input transducers. Set the phase and earth fault trip settings to minimum. Inject single phase current into each of the phase and earth fault inputs, in turn. Slowly increase the current until the I>Is LED (yellow) operates and record the pick-up current. Reduce the current until the LED extinguishes and record this reset level. Check that all pick-up current levels are within 95% and 105% of the applied setting, and that the reset levels are $\pm 95\%$ of the measured pick-up value. Note: Depending on the applied setting, a trip could occur if the current is on for longer than the relay operating time. This may be undesirable while measuring pick-up and reset levels. The fault trigger setting (in the data storage menu) can be used to disable tripping indication temporarily during this test. Restore the phase and earth settings to calculated values.

5.4. Thermal characteristics

This test checks the accuracy of the thermal characteristics and that the relay has been correctly set. The relay should be fully programmed to the calculated settings, output relays mapped to the protection scheme being used for this test. The NPS weighting factor, K, should be set to zero in order to allow a single phase test of the thermal characteristic. Inject a current equal to 2x the set thermal overload setting (Iq) through the three phase inputs connected in series. Depending on the selected heating time constant (th) set, the relay should operate in the following times assuming the initial thermal state = 0% ie cold curves:-

τ_c value (mins)	Operating time (sec)
0.5	8.6
1.0	17.3
2.0	34.5
3.0	51.8
4.0	69
5.0	86.3
10	173
15	259
20	345
25	432
30	518
50	863
100	1726

The measured times should be $\pm 5\%$ of these values. Restore the NPS weighting factor, k, to the required value. The cooling characteristic can be checked by timing the rate of reduction of the thermal capacity. A sufficiently accurate check can be made by employing the restart inhibit feature. Programme this to operate an output contact and to reset at 50% of thermal capacity.

Start external timer at 100% (trip) level and the timer to be stopped when 50% is reached. Depending on the selected cooling time constant (tc) the re-start inhibit, with setting of 50% thermal capacity, should reset in the following times assuming the initial thermal state = 100%

t_{d} value (mins)	Re-set time (sec)
0.5	20.8
1.0	41.6
2.0	83.2
3.0	124.8
4.0	166.4
5.0	207.9
10	415.9
15	623.8
20	831.8
25	1039.7
30	1247.7
50	2079.4
100	4158.9

5.5. Over/under current protection

Two high set instantaneous or delayed elements are available designated phase fault trip and phase fault alarm. Where the motor control equipment (ie contactor or circuit breaker) is only capable of breaking a limited fault current, one of these functions can be mapped to a set of contacts wired to trip an upstream circuit breaker with sufficient fault breaking capability if the fault current is above the limit. If used, this feature should be checked. For fault levels within the capability of the controlling device the high set overcurrent trip feature should be employed to trip the local breaker instantaneously and tested as follows. The starter (I>Is) LED should be used. Inject a current below the setting and increase this until the LED lights. Decrease the current and read the value at which the LED extinguishes. Record all values. The pick-up should be $\pm 5\%$ of the setting. For high levels of current the thermal level of the relay must not be exceeded. Refer to the Performance Specification in this manual. To avoid exceeding the thermal withstand an alternative test method is as follows. Increase current to 105% of setting and switch on/off three times to prove operation.

Set current to 95% of setting and switch on/off three times to prove non-operation. To test the operating time, a current of 1.5 times setting should be applied and the set time delay checked by means of a time interval meter connected to the programmed contacts. The timer should be started by the injection source and stopped by the relevant contacts. Test each phase. Similarly, the earth fault and undercurrent elements should be tested.

5.6. Phase unbalance protection

For this test, an injection test set with a variable 3 phase output is require (such as a pair of doble test sets). The current unbalance (or NPS) as selected on the relay is injected, this value should be read on the metering display as ID or I2, and depending on the time multiplier set, the relay should trip in accordance with the inverse time characteristics.

5.7. Number of starts

The relay should be checked to ensure that the control selected and wired into the 'close' circuit is operated when the 'starts per period' feature set has been exceeded.

5.8. Temperature protection

The correct operation of each RTD or thermistor used should be checked by simulating the operation of the devices with potentiometers. Table 1 shows the RTD resistance values for different types at various temperatures. The operation of the Rho 3 relay should be checked by monitoring both the metered display and output trip contacts at high simulated RTD temperatures.

5.9. Output and status configuration

The operation of every output relay contact (both normally open and normally closed) and every status input unit used in the motor protection scheme must be checked to ensure correct programming and operation.

5.10. Circuit breaker fail

The 2-stage circuit breaker failure feature should be tested if required by the application. If only one of the stages is to be used then only CBF delay I need be tested. In order to test both stages of the CBF feature then the two CBF delays should be programmed to operate output contacts other than the main trip output. They should also be programmed with their appropriate delays. CBF delay I is initiated by the main trip output. After timing out it generates a trip output of its own and also initiates CBF delay 2 which subsequently generates a final trip output. Connect the main trip output to start a time interval meter. Connect the output from CBF delay I to stop both the timer and the current source. Inject current of 2x setting into any pole and record the first CBF time delay. Connect the CBF delay I output to start the time interval meter. Connect the output from CBF delay 2 to stop both the timer and the current source. Inject current of 2x setting into any pole and record the second CBF time delay. Check that the measured delays are within $\pm 5\%$ of the set values.

Temp C ⁰	OHMS 100 OHM Pt (DIN 43760)	OHMS 120 OHM NI	OHMS 100 NI	OHMS 10 OHM Cu
0	100.00	120.00	100.00	9.04
10	103.90	127.17	105.97	9.42
20	107.79	134.52	112.10	9.81
30	111.67	142.06	118.36	10.19
40	115.54	149.79	124.82	10.58
50	119.30	157.74	131.45	10.97
60	123.24	165.90	138.25	11.35
70	127.07	174.25	145.20	11.74
80	130.80	182.84	152.37	12.12
90	134.70	191.54	159.70	12.51
100	138.50	200.54	167.20	12.90
110	142.27	209.85	174.87	13.28
120	146.06	219.29	182.75	13.67
130	149.82	228.96	190.80	14.05
140	153.58	238.85	199.04	14.44
150	157.32	248.95	207.45	14.83
160	161.04	259.30	216.08	15.22
170	164.76	269.91	224.92	15.61
180	168.47	280.77	233.97	16.00
190	172.46	291.96	243.30	16.39
200	175.84	303.46	252.88	16.78

Table 1

7SG17 Rho 3

Multifunction Protection Relays

Document Release History

This document is issue 2010/02. The list of revisions up to and including this issue is:

Pre release

2010/02	Document reformat due to rebrand

Software Revision History

--	--	--

The copyright and other intellectual property rights in this document, and in any model or article produced from it (and including any registered or unregistered design rights) are the property of Siemens Protection Devices Limited. No part of this document shall be reproduced or modified or stored in another form, in any data retrieval system, without the permission of Siemens Protection Devices Limited, nor shall any model or article be reproduced from this document unless Siemens Protection Devices Limited consent.

While the information and guidance given in this document is believed to be correct, no liability shall be accepted for any loss or damage caused by any error or omission, whether such error or omission is the result of negligence or any other cause. Any and all such liability is disclaimed.

1 MAINTENANCE INSTRUCTIONS

The Rho 3 is a maintenance free relay, with no user serviceable parts. During the life of the relay it should be checked for operation during the normal maintenance period for the site on which the product is installed. It is recommended the following tests are carried out:

- 1 Visual inspection of the metering display (every year)
- 2 Operation of output contacts (every 2 years)
- 3 Secondary injection of each element

2 DEFECT REPORT FORM

DEFECT REPORT FORM

Please copy this sheet and use it to report any defect which may occur.

Customers Name & Address:			Contact Name:		
			Telephone No:		
			Fax No:		
Supplied by:			Date when installed:		
Site:			Circuit:		
Date Found:	During Commissioning:	During Maintenance:	From a System Fault:	Other, please state:	
Product Name:			Article Number:		
Software Version:			Serial Number:		
Copy any message displayed by the relay:					
Describe Defect:					
Describe any other action taken:					
Signature:		Please print name:		Date:	
For Siemens Protection use only:					
Date Received:	Contact Name:	Reference No:	Date Acknowledged:	Date of Reply:	Date Cleared:

Siemens Protection Devices Ltd
 PO Box 8
 HEBBURN
 Tyne & Wear
 NE31 1TZ
 England
 Telephone: (0191) 401 5555
 Fax: (0191) 401 5575

7SG17 Rho 3

Multifunction Protection Relays

Document Release History

This document is issue 2010/02. The list of revisions up to and including this issue is:

Pre release

2010/02	Document reformat due to rebrand

Software Revision History

--	--	--

The copyright and other intellectual property rights in this document, and in any model or article produced from it (and including any registered or unregistered design rights) are the property of Siemens Protection Devices Limited. No part of this document shall be reproduced or modified or stored in another form, in any data retrieval system, without the permission of Siemens Protection Devices Limited, nor shall any model or article be reproduced from this document unless Siemens Protection Devices Limited consent.

While the information and guidance given in this document is believed to be correct, no liability shall be accepted for any loss or damage caused by any error or omission, whether such error or omission is the result of negligence or any other cause. Any and all such liability is disclaimed.

The 7SG17 is supplied in either a size 6 or size 8 case, depending on the binary input, RTD input and output relay requirement.

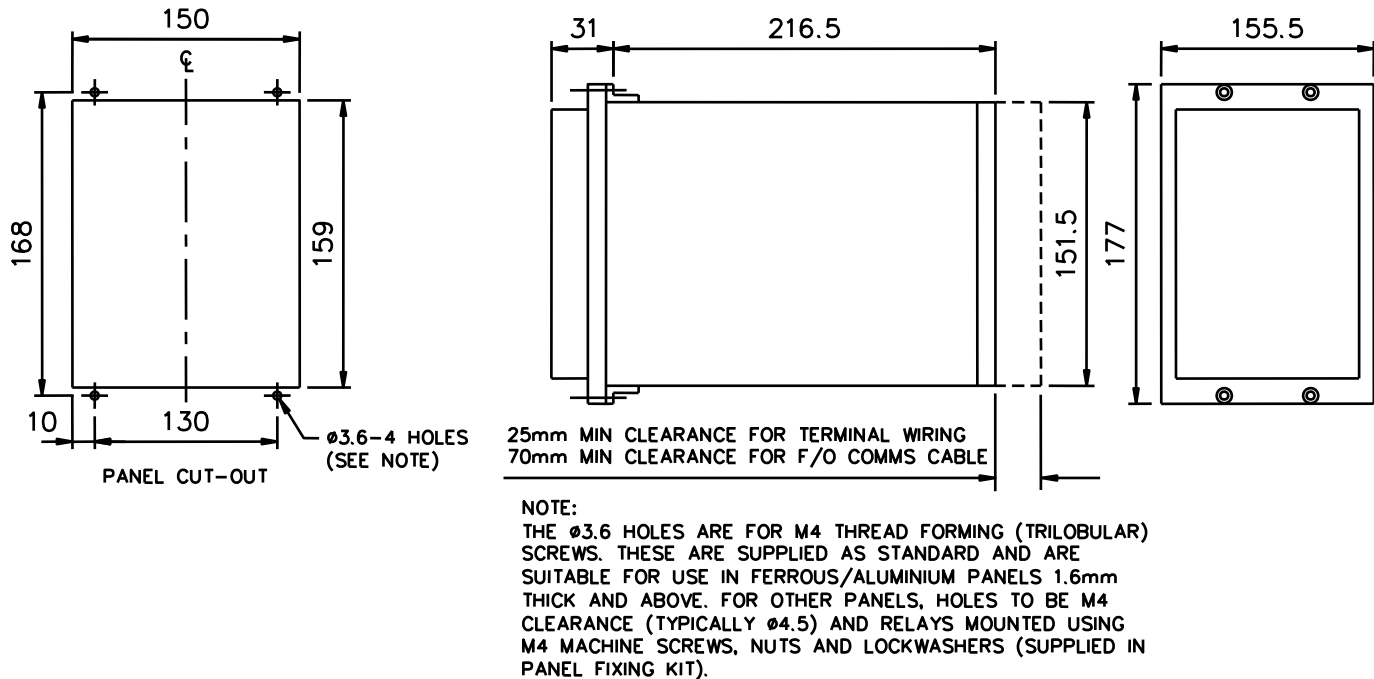

Fig 1. E6 Case Dimensions

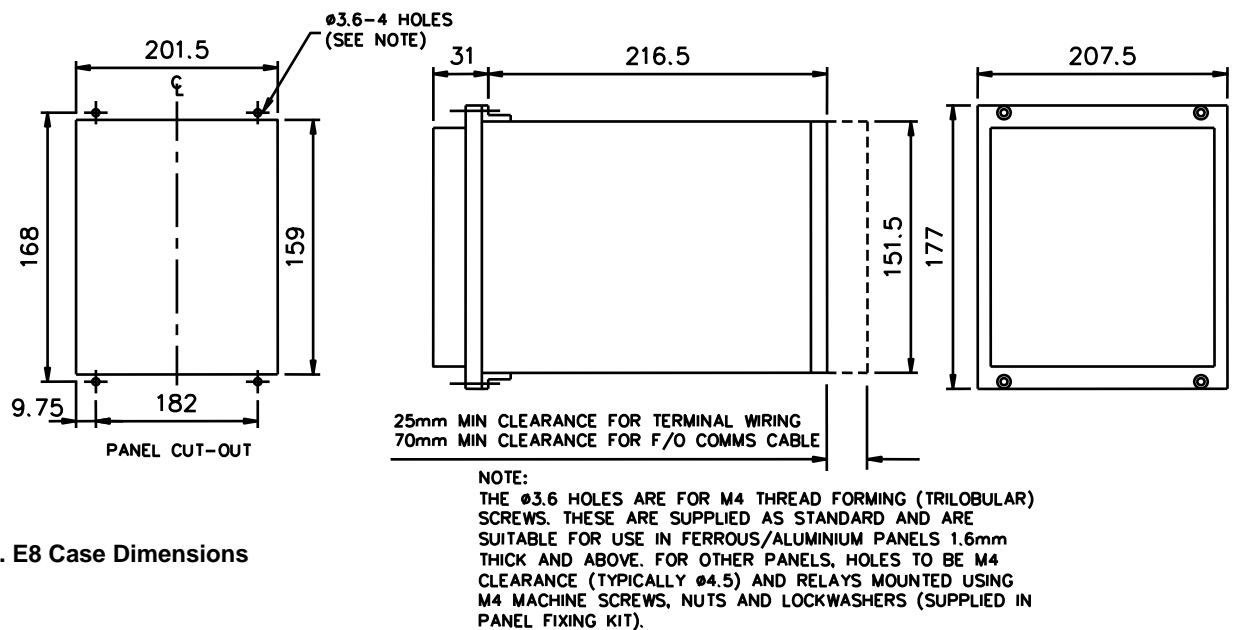

Fig 2. E8 Case Dimensions

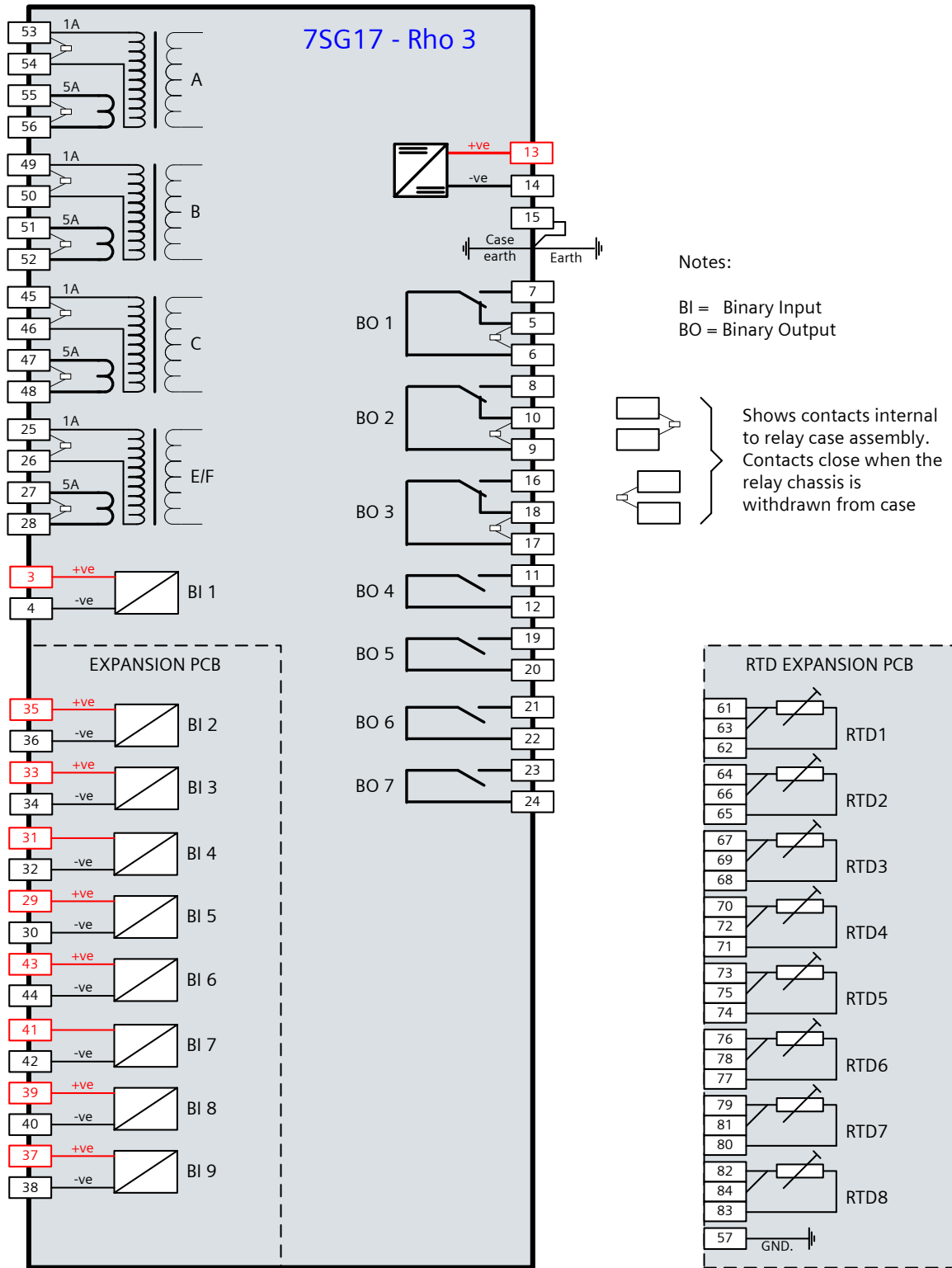

Fig 3. Connection Diagram for 7SG17 Relay

7SG17 Rho 3

Multifunction Protection Relays

Document Release History

This document is issue 2010/02. The list of revisions up to and including this issue is:

Pre release

2010/02	Document reformat due to rebrand

Software Revision History

--	--	--

The copyright and other intellectual property rights in this document, and in any model or article produced from it (and including any registered or unregistered design rights) are the property of Siemens Protection Devices Limited. No part of this document shall be reproduced or modified or stored in another form, in any data retrieval system, without the permission of Siemens Protection Devices Limited, nor shall any model or article be reproduced from this document unless Siemens Protection Devices Limited consent.

While the information and guidance given in this document is believed to be correct, no liability shall be accepted for any loss or damage caused by any error or omission, whether such error or omission is the result of negligence or any other cause. Any and all such liability is disclaimed.

Table of Contents

1 INTRODUCTION	3
2 NON-MOTOR APPLICATIONS	3
2.1 Negative phase	3
2.2 Single phase Vs three phase thermal overload	3
3 DIAGRAMS FOR NON-MOTOR APPLICATIONS	3
4 INSTALLATION AND COMMISSIONING	6

1 INTRODUCTION

Rho 3 series of relays has been developed primarily to provide a multi function protection system for 3-phase a.c. induction motors, typically for those employed on high voltage systems with ratings in excess of 75kW. The principal protection functions are those related to thermal overload and this function, along with many of the others incorporated in Rho 3, are suitable for protecting other items of plant, eg cables, power transformers, etc. The relay incorporates comprehensive thermal characteristics to IEC60255-8 (thermal electrical relays). A series of Rho 3 variants is available specifically for plant other than motors. The only difference between Rho 3 supplied for non-motor applications and those for motor applications is that on the latter there are two additional LED's available on the relay fascia plate engraved "Motor Starting" and "Motor Running". These are not included on the Rho 3 relays supplied for nonmotor applications. All setting and programming features, also the input/output, relay configuration and the communication features are identical. Any features in the setting menu which is specific to motors need not be selected when a Rho 3 for non-motor application is employed for protecting other plant, eg cables, transformers, capacitor banks, etc. In the following, information is given about the application of Rho 3 for non-motor electrical plant. For all other data refer to the main Technical Manual.

2 NON-MOTOR APPLICATIONS

2.1 Negative phase

sequence/unbalanced current Other than generators and motors, electrical plant is usually tolerant of negative phase sequence current (ie resulting from 3-phase unbalanced currents). For these applications the negative phase sequence (n.p.s.) current weighting factor must be set to zero, the thermal protection then uses the average of the three RMS phase currents instead of an equivalent current compiled from positive phase sequence (p.p.s) and n.p.s. current x a weighting factor.

The unbalanced current function need not be selected, it is available should this feature be considered useful (eg phase difference or n.p.s overcurrent).

2.2 Single phase Vs three phase thermal overload

If it is known that the three phases can have significantly different loads and that the three phase conductors of the electrical plant being protected are independent, eg single phase cables as apposed to 3- phase cables, then it may be considered that the averaging feature of Rho 3's thermal overload function may not be adequate to protect all three phases against overload damage. In this case a separate Rho 3 relay is required for each phase. Each relay must be employed connecting all three phase current inputs in series thus employing three relays in total for the three phases of the primary circuit. Drawing Rho 3/D5 attached shows the recommended schematic diagram for single phase protection. The three relays each have an earth fault c.t. input as well as three phase overcurrent inputs. The recommended scheme shows all three earth fault elements connected in series.

If instantaneous, sensitive earth fault is required and the c.t. residual connection application shown is employed (eg for power transformer primary circuit earth fault) it may be necessary to employ a stabilising resistor to prevent mal-operation at circuit switch-on. Drawing Rho 3/D4 shows the schematic distance for three phase overload, employing only one relay.

3 DIAGRAMS FOR NON-MOTOR APPLICATIONS

Figure 1: Rho 3/D4 - Typical schematic diagram for Rho 3 three phase thermal overload protection (non-motor applications)

Figure 2: Rho 3/D5 - Typical schematic diagram for Rho 3 single phase thermal overload protection (non-motor applications)

Figure 1: Rho 3/D4 - Typical schematic diagram for Rho 3 three-phase thermal overload protection (non-motor applications)

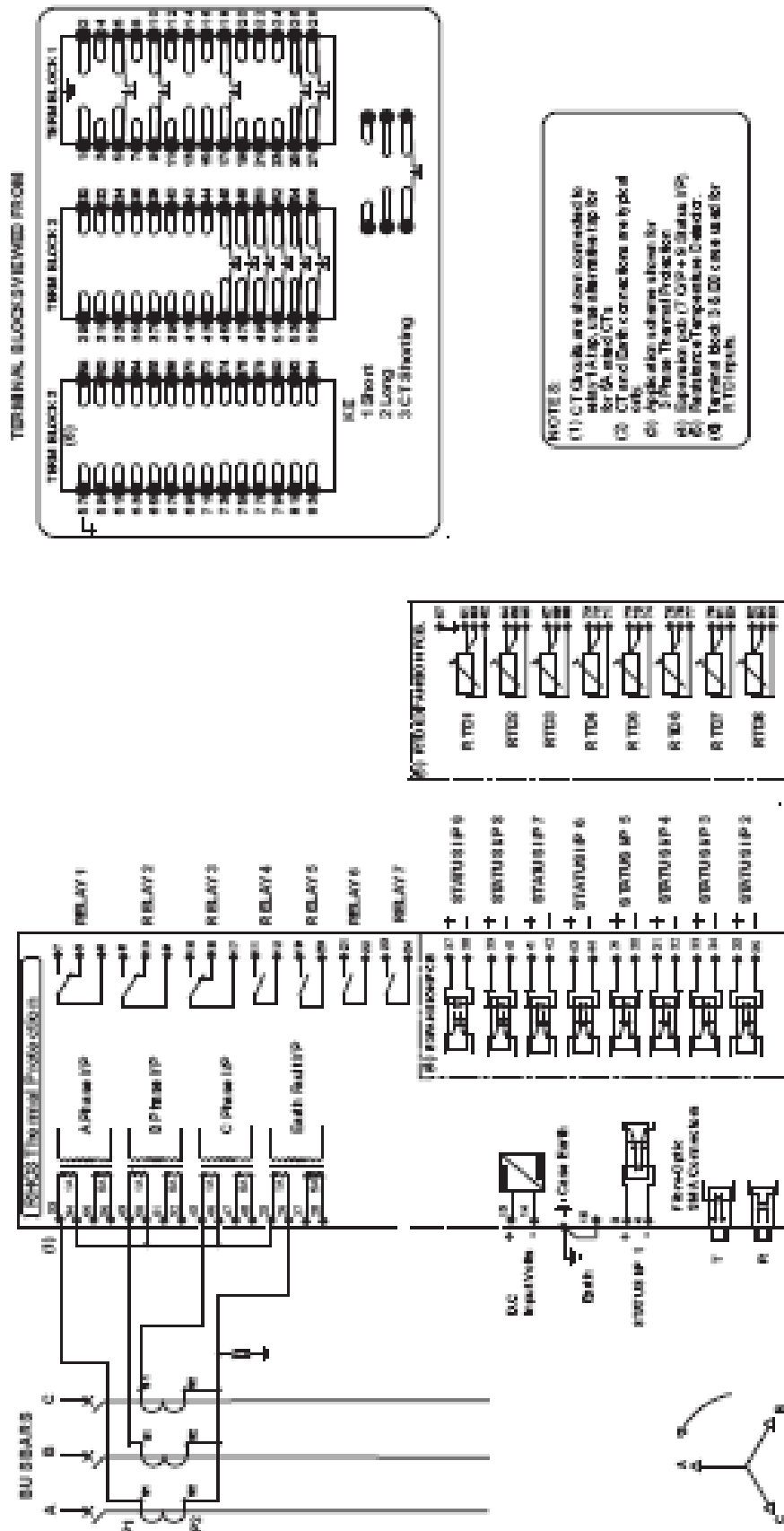

4 INSTALLATION AND COMMISSIONING

Refer to section 7 of this technical manual for Rho 3 motor protection series.

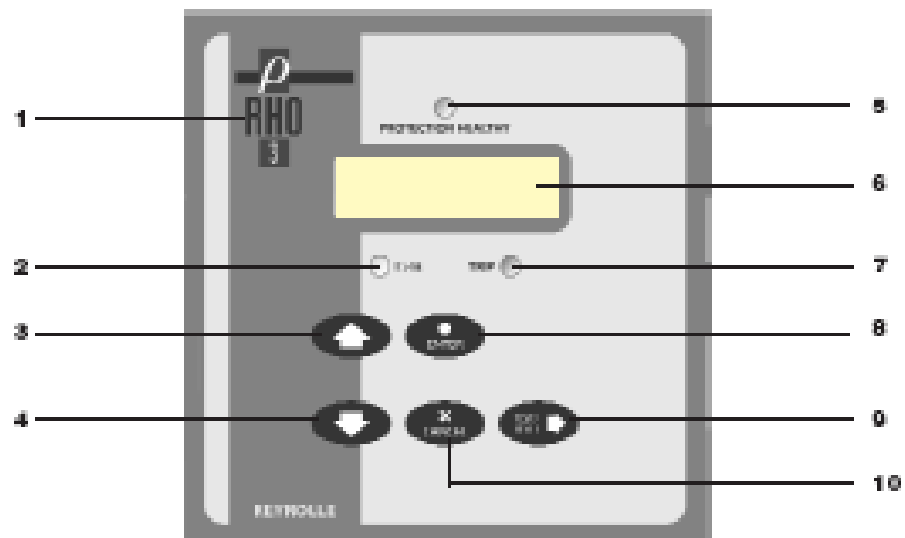

- 1 Relay type
- 2 Yellow LED - protection starter pickup
- 3 Page-up key
- 4 Page-down key
- 5 Green LED protection healthy
- 6 LCD display (backlit)
- 7 Red LED - relay trip
- 8 Enter key
- 9 Test and reset key - also enables sub-menu access
- 10 Cancel key

(Figure 1 HMI for Rho 3 (Non-motor application)

Siemens Protection Devices Limited
P.O. Box 8
North Farm Road
Hebburn
Tyne & Wear
NE31 1TZ
United Kingdom
Phone: +44 (0)191 401 7901
Fax: +44 (0)191 401 5575
Web: www.siemens.com/energy

PTD 24h Customer Support
Phone: +49 180 524 7000
Fax: +49 180 524 2471
E-mail: support.energy@siemens.com
Data is subject to change without notification.