

Features

- Rugged modular construction
- Rack or flush mounting
- Range of function types
- Draw out module
- M4 screw terminals
- Operating & reset coils are available for 24, 32, 48, 110, 125 or 250V DC nominal
- Time delay operate options
- Contacts are of fine silver designed & manufactured to ensure low resistance & high reliability
- Optional gold plated contacts suitable for low currents
- Magnetic blowouts to further enhance contact breaking capability may be specified
- Custom contact configuration
- Custom labeling
- High visibility electro-mechanical flag indication
- Made in Australia

Application

The 6R MATRIX range has been developed to provide design engineers with a modular system of auxiliary relays to meet a wide variety of system configurations. Based on our well proven 6R heavy duty control relay, the 6R MATRIX system offers numerous benefits:

- ▶ Modular configuration to simplify panel layout & circuit design
- ▶ High packing density to reduce panel space requirements
- ▶ Standard component design to reduce delivery lead times
- ▶ Case suitable for both flush panel & 19 inch rack mounting
- ▶ Standard draw out module
- ▶ Heavy duty M4 screw terminals

Refer also to the following RMS data sheets for detailed information on product applications & technical specifications:

- [6R Relay Series](#)
- [6R Technical Data Supplement](#)
- [M Series MATRIX Case System](#)
- [6RM QUAD 4 Element Flag Relays](#)
- [6R MATRIX Pre Defined Relays](#)

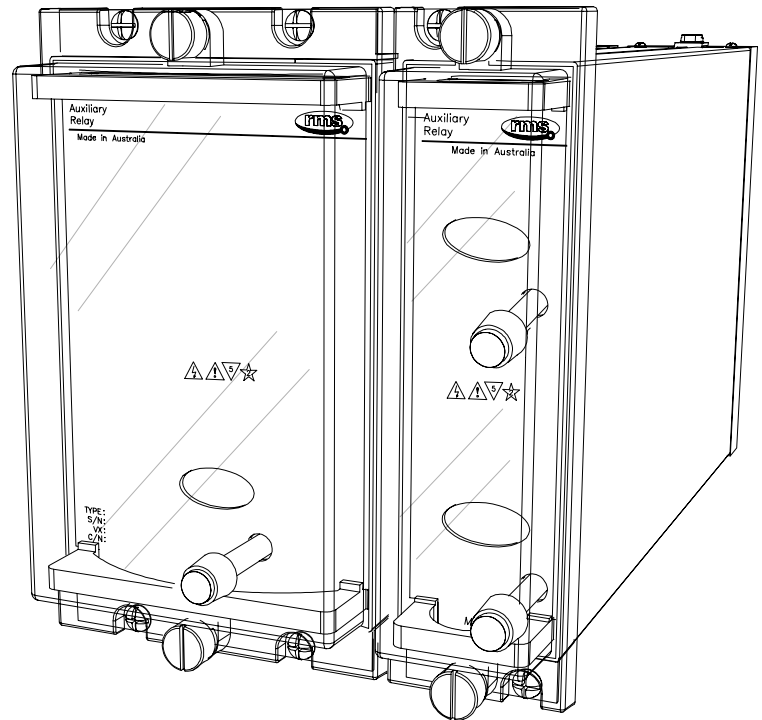

Functional Elements

	Series	Page
HIGH SPEED TRIPPING RELAYS	2HSM	4
AUXILIARY RELAYS	6RM	8
TIME DELAY ELEMENTS	2TM649	11
TRIP CIRCUIT SUPERVISION	1TM	12

Cases

	Series	Page
Relay Construction	M	2
Case System Summary	M	3
MATRIX Case Details	M	15

Introduction

Made in Australia

The effect of a fault on a power system is dependent on the speed with which the fault can be detected & isolated. Modern protection schemes incorporate ever increasing functionality through the application of digital techniques to protection relay technology. The requirement for highly reliable tripping & control relay elements does however remain & often constitutes a significant cost & space requirement for protection panel designs. The 6R MATRIX system fulfills this need by providing a compact, flexible & cost effective solution.

6R MATRIX Construction

Specification Process

- ▶ Select the functional elements required to meet system design requirements;
- ▶ Complete the options section for each functional element & complete details;
- ▶ Select case & accessories;
- ▶ Group functional elements to fill cases such that panel space is minimized.

Each 6R MATRIX relay is comprised of two main parts:

1. Outer casing
2. Functional element(s)

The completed relay is shipped from the factory fully assembled but for flexibility, each part is specified & numbered separately.

The main components & features are depicted below for a single element & a double element both mounted in a size 2 M Series case:

One element per case

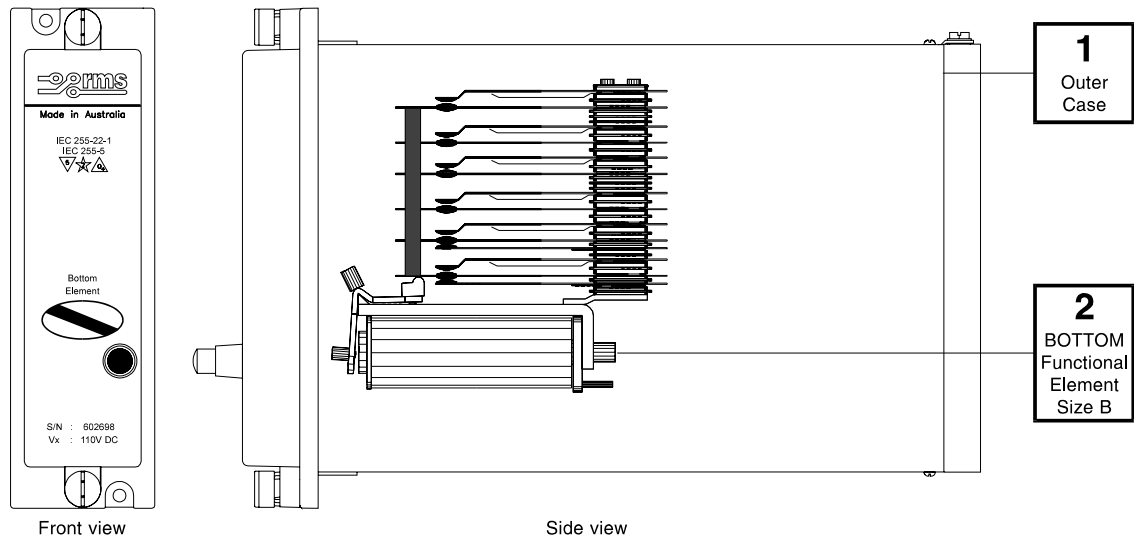

Two elements per case

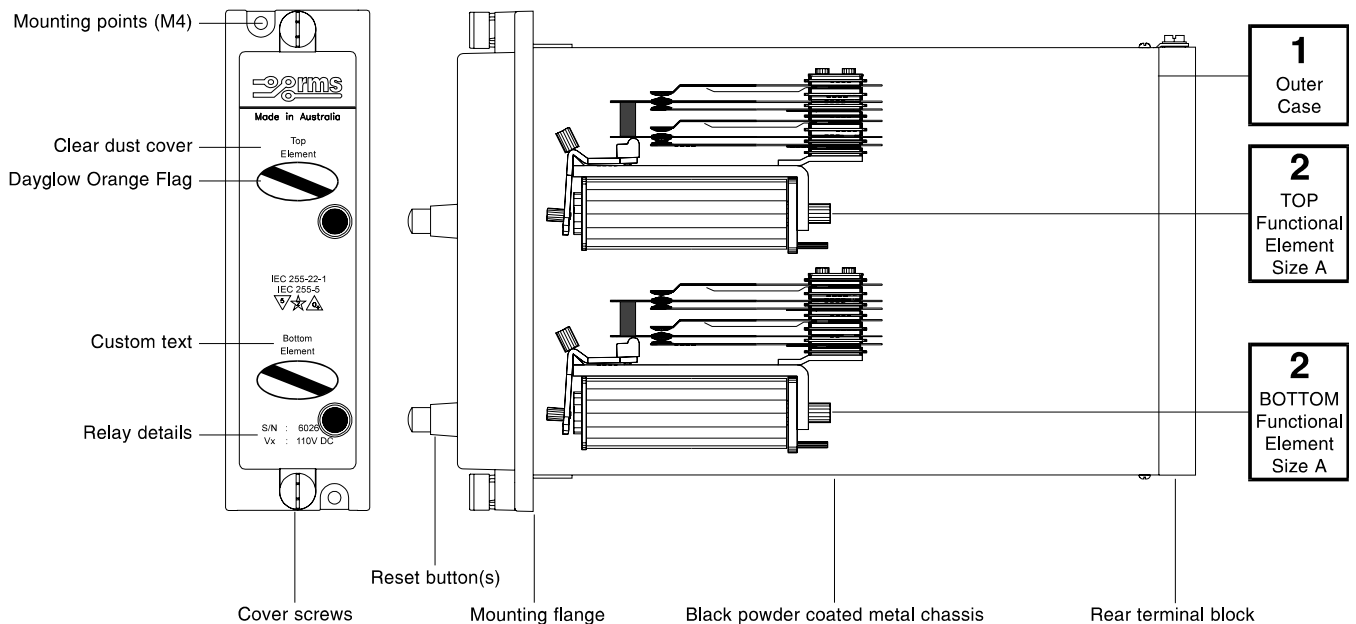

Case Mounting

The following standard features are provided:

- RACK & FLUSH MOUNTING
- DRAW OUT RELAY MODULE
- REAR M4 SCREW TERMINALS

Case Construction

The outer case is manufactured from zinc coated mild steel providing considerable strength & black powder coated surface finish for corrosion protection. Relay elements are mounted on fabricated fibreglass & Acetal components to provide reliable electrical isolation & simple cost effective construction.

Terminal Blocks

High quality moulded terminal block(s) are utilized. The draw out function is made possible through the use of inner & outer terminal blocks, each with silver plated contact fingers to provide high current rating & very low electrical resistance.

M4 screw terminals allow 2x crimp lug connections per point. Space efficient design allows 28 contact points per terminal block.

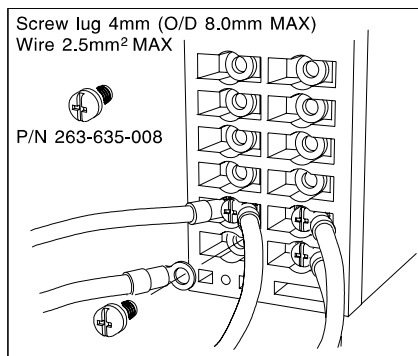

Reset Buttons

Latching relays are provided with front mounted reset buttons.

Flag Indicators

Each relay element is supplied with an operation (target) indicator. The indicator consists of a high visibility solid day glow orange mechanical flag which drops on energisation or de-energisation.

Case System Summary

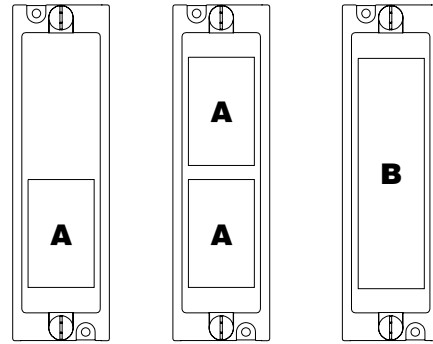

1 X A Element 2M28-S-1A case
2 x A Element 2M28-S-2A case
1 x B Element 2M28-S-1B case

Size 2M Case Element Fit

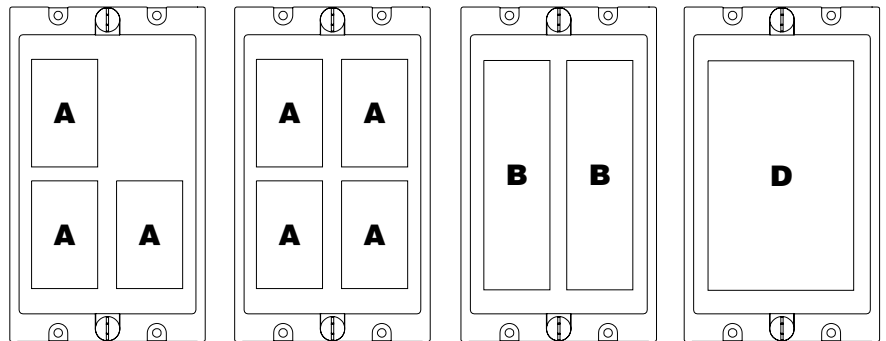

3 x A Element 4M28-S-3A or 4M56-S-3A case
4 x A Element 4M28-S-4A or 4M56-S-4A case
2 x B Element 4M28-S-2B or 4M56-S-2B case
1 x D Element 4M28-S-1D or 4M56-S-1D case

Size 4M Case Element Fit

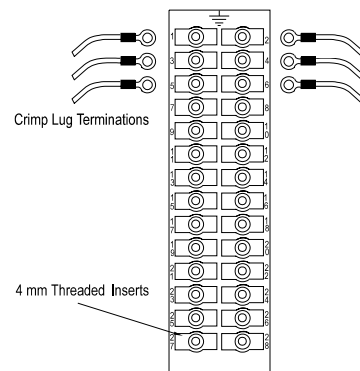

Case terminations (Rear view)

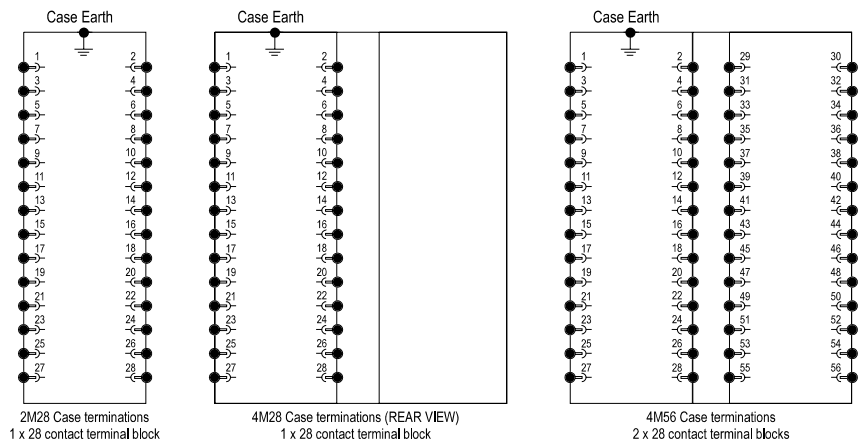

2M28 Case terminations 1 x 28 contact terminal block

4M28 Case terminations (REAR VIEW) 1 x 28 contact terminal block

4M56 Case terminations 2 x 28 contact terminal blocks

Application

The effect of a fault on a power system is dependent on the speed with which the fault can be detected & isolated. The 2HS Series multi-contact high-speed trip relays are used for this isolating function providing simultaneous tripping outputs.

The operating element for the 6R MATRIX High Speed Trip functional elements are designated 2HSM. A high speed coil provides fast operation (<10ms at nominal DC operating voltage), with specially constructed anti bounce buffers ensuring effective damping of the contacts to avoid excessive bounce.

The Type 2HSM relays may be broadly divided into two groups:

- Low burden tripping relays
- High burden tripping relays

High burden tripping relays are designed to withstand the 10uF capacitor discharge test such that the relay will not operate when a 10uF capacitor charged to 120% of nominal operating voltage is applied across the coil of the relay.

Low Burden Trip Relays

2HSM 502, 504, 506, 507, 508, 509

These are low burden versions of types 2HSM relays respectively & are suitable for applications where immunity to capacitance discharge & high minimum operation currents are not required. Circuit diagrams for types 2HSM504, 506, 508, 509 are as per 2HSM514, 516, 518, 519 without C1, R1 or R2 loaded.

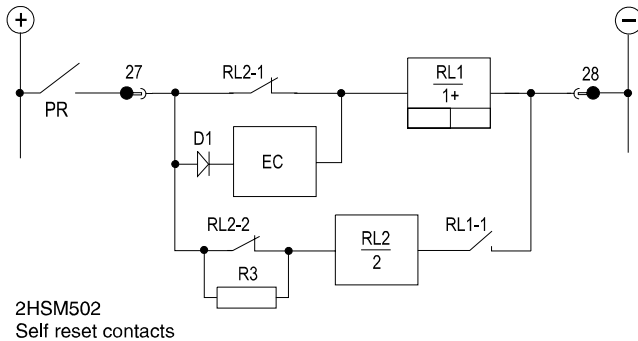

High Burden Trip Relays

These relays are suitable for application in high security circuit breaker tripping circuits & in particular where the initiating contact may be remote from the relay. The high burden may also allow the satisfactory operation of external series elements.

These relays have a high burden to provide immunity to capacitance discharge currents & power to the coil is cut off at operation or is economized to a low figure to provide thermal protection.

Operation of Series Elements

External relay elements are often employed for additional flagging & alarm functions. These elements are typically much slower than the primary high speed tripping relay so care must be taken to ensure reliable operation of the series element before the series trip signal is cut off or economized. In these circumstances a 2HSM relay with a time delayed (TD) cut off should be employed.

2HSM High Speed Tripping Relay Elements

HIGH BURDEN SELF-RESETTING TYPE 2HSM 512, 513, 520

This type uses a contact on the main contact stack (RL1-1), to energize a separate economizing element. After operation this reduces the burden by switching a second coil in series with the main element. The 2HSM520 version has a "slug" delay relay element fitted to provide time for series relays to operate.

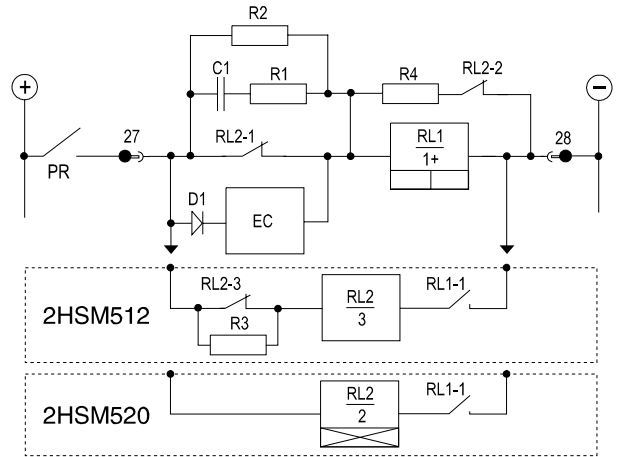

HIGH BURDEN LATCHING TYPE WITH INST. CUT OFF 2HSM 514, 516, 517, 518, 519

These relays incorporate a break contact (RL1-b), in series with the operate coil. Located below the main contact stack, it is arranged to break the coil circuit once the relay mechanism has completely operated. This reduces the relay burden to zero when the mechanical latching of the contact has occurred. An arc suppression circuit (R1 & C1), is used to protect RL1-b.

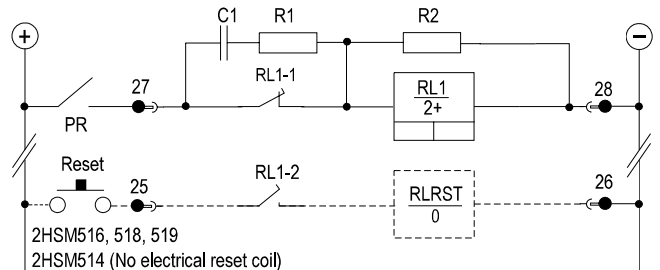

RELAYS WITH TIME DELAYED CUT OFF 2HSM 521, 522, 524, 525, 526

(See also 2HSM520 above)
These relays have time delayed cut off circuits such that the burden is reduced to zero 40 to 100ms, after energisation by the use of a second attracted armature "slug" delay element. This delay allows ample time for any flagging or auxiliary elements in series with the tripping relay to operate before cut off. Contact RL1-1 is fitted to ensure the latching contacts & flag cannot be reset until the initiate voltage has been removed. The 2HSM521 is a special version requiring an auxiliary supply to provide a 2s delay on drop off.

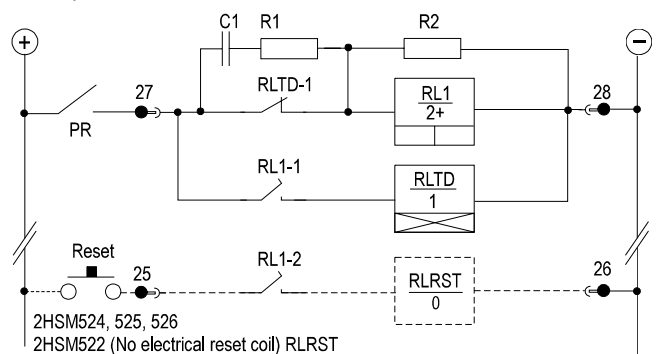

Table 1

Relay Type	Contact Refer note 1	Flag	Cut off	Burden	Element Size	Minimum Case
2HSM502	SR	HR	Econ.	Low	B	2M28-S-1B
2HSM504		HR	Inst.	Low	B	2M28-S-1B
2HSM506	ER	HR	Inst.	Low	B	2M28-S-1B
2HSM507		ER	Inst.	Low	B	2M28-S-1B
2HSM508		H/ER	Inst.	Low	B	2M28-S-1B
2HSM509	H/ER	HR	Inst.	Low	B	2M28-S-1B
2HSM512	SR	HR	Inst.	High	B	2M28-S-1B
2HSM513	SR	NF	Inst.	High	B	2M28-S-1B
2HSM514		HR	Inst.	High	B	2M28-S-1B
					D	4M56-S-1D
2HSM516	ER	HR	Inst.	High	B	2M28-S-1B
					D	4M56-S-1D
2HSM517		ER	Inst.	High	B	2M28-S-1B
					D	4M56-S-1D
2HSM518		H/ER	Inst.	High	B	2M28-S-1B
					D	4M56-S-1D
2HSM519	H/ER	HR	Inst.	High	B	2M28-S-1B
					D	4M56-S-1D
2HSM520	SR	HR	TD	High	B	2M28-S-1TB
			Econ.		D	4M28-S-1TD
					D	4M56-S-1TD
2HSM521	SR	HR	TD	High	B	2M28-S-1TB
			Econ.		D	4M28-S-1TD
					D	4M56-S-1TD
					D	4M56-S-1TD
2HSM522		HR	TD	High	B	2M28-S-1TB
					D	4M28-S-1TD
					D	4M56-S-1TD
2HSM524	ER	HR	TD	High	B	2M28-S-1TB
					D	4M28-S-1TD
					D	4M56-S-1TD
2HSM525		H/ER	TD	High	B	2M28-S-1TB
					D	4M28-S-1TD
					D	4M56-S-1TD
2HSM526	H/ER	HR	TD	High	B	2M28-S-1TB
					D	4M28-S-1TD
					D	4M56-S-1TD

Maximum Contacts	
Magnetic Blowouts M or B*	Heavy Duty M or B*
1	2
9	13
10	13
9	12
9	12
9	12
9	12
9	13
9	13
10	13
20	20
9	12
19	19
9	12
19	19
9	12
19	19
9	12
19	19
5	8
10	13
-	20
5	8
10	13
-	20
-	5
10	13
-	20
-	3
10	12
-	20
-	3
10	12
-	20
-	3
10	12
-	20

KEY: H/ER - Hand / electrical reset SR - Self reset HR - Hand reset
 TD - Time delay 40 to 100ms ER - Electrical reset Econ. - Economy element
 M - Make (N/O) contacts B - Break (N/C) contacts Inst. - Instantaneous cut off
 Cont. - Continuously rated coil C/F - Consult factory NF - No flag

NOTES: 1. The Contact & Flag code should be read in conjunction with the section on flag & contact reset function on the following page.
 2. C/O - Changeover contacts may be specified but each C/O contact replaces 1.5 M or B contacts.

EXAMPLE: 2HSM512-B2 represents a high burden high speed relay with a self reset flag with a maximum of 9 M or 9 B (without magnetic blowouts), hand reset contacts. As the relay is an element size B, one of these elements may be fitted in a size 2M28-S-1B case.

Contact Stack Arrangement

The number of contacts indicated in Table 1 are the maximums that can be fitted for the element size. Fewer contacts may be specified to save cost. The operate time for relay elements with 14 to 20 contacts is <12ms at nominal operate voltage.

Mixed Contacts Stacks

Mixed M & B contact arrangements may be specified provided the total number does not exceed the maximum indicated in table 1 for the relay element size specified above. Changeover contacts (C/O), are also available but must be counted as 1.5 M or B contacts & the result rounded down to the nearest integer & not exceed the maximum indicated in table 1



Flag & Contact Reset Function

COMBINED OPERATION & COMBINED RESET

Types: 2HSM504, 507, 508, 514, 517, 518, 522, 525

With these types the flag & contacts operate & reset together. I.e.

When the relay is tripped the flag changes state & the contacts latch. Both the flag & contacts are reset if either the reset button is pressed or the electrical reset coil is energized.

COMBINED OPERATION & INDEPENDENT RESET

Types: 2HSM506, 509, 516, 519, 524, 526

With these types the flag & contacts operate together but may be reset independently. I.e. When the relay is tripped the flag changes state & the contacts latch. The contacts only are reset if the electrical reset coil is energized or the contact reset button is pressed. In both cases the flag is not reset. The flag can only be reset if the independent flag reset button is pressed.

Contact Bounce & Self Cleaning

Contact bounce occurs due to the speed at which the contacts meet. If too much coil power is used then the contacts will come together with too much force causing excessive bounce. It is therefore important to only fit relay coils with adequate power to provide the force required to switch the relay at the minimum operate voltage 65% of nominal.

In addition contact bounce can be greatly reduced through the addition of anti-bounce buffers. These components are added to each contact to provide a damping wiping motion when the contacts meet thus dissipating the force which would otherwise produce bounce.

Contacts are constructed from silver / copper alloy, shaped & positioned to ensure very reliable, low resistance operation. Over travel of the contacts during each operation causes a wiping action ensuring a clean "make".

The design of the contact surface is spherical such that when the contacts are driven to an over travel position they actually wipe. This wiping motion is part of the damping action mentioned above but also provides a wiping action which serves to clean the contact area.

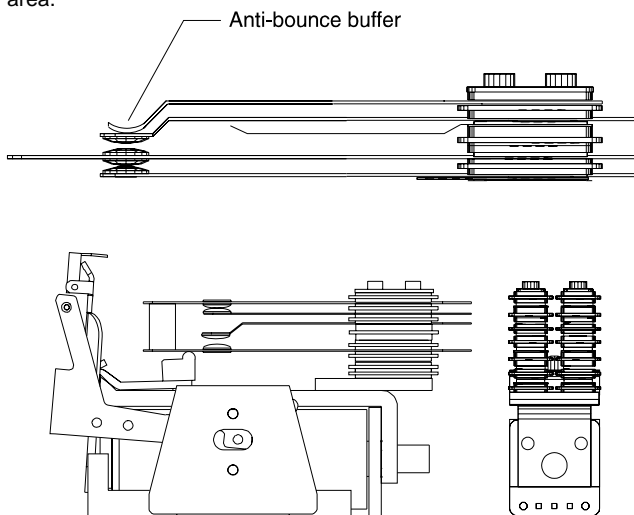

Flag Indicators

Each relay element is supplied with an operation (target) indicator. The indicator consists of a high visibility solid day glow orange mechanical flag which drops on energisation (Type 2F).

2HSM High Speed Tripping Relay Elements

Magnetic Blowouts

Heavy duty contacts may be optionally fitted with magnetic blowouts to further increase the DC breaking capacity. This feature is particularly useful for breaking highly inductive loads such as that presented by high voltage circuit breaker trip coils. Refer to the 6R Technical Data Supplement for details.

Electrical Reset Mechanism

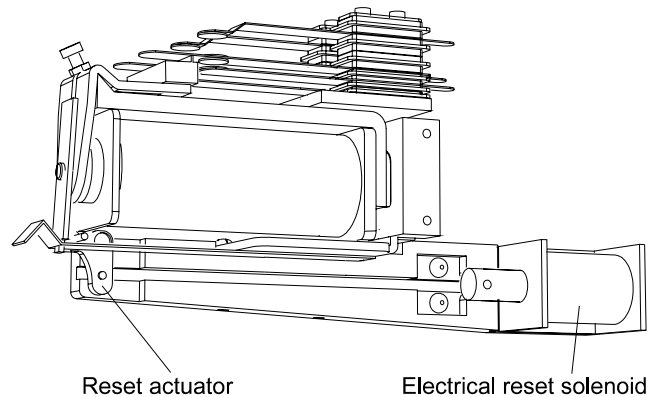

Where electrical reset mechanisms are fitted the

Wiring Diagram Example

6R MATRIX relays have custom wiring determined by the number & configuration of the contacts. To convey this information a label is attached to the internal side plate depicting the wiring information. As this stays with the product (unlike the paper wiring diagram also supplied), it cannot be lost.

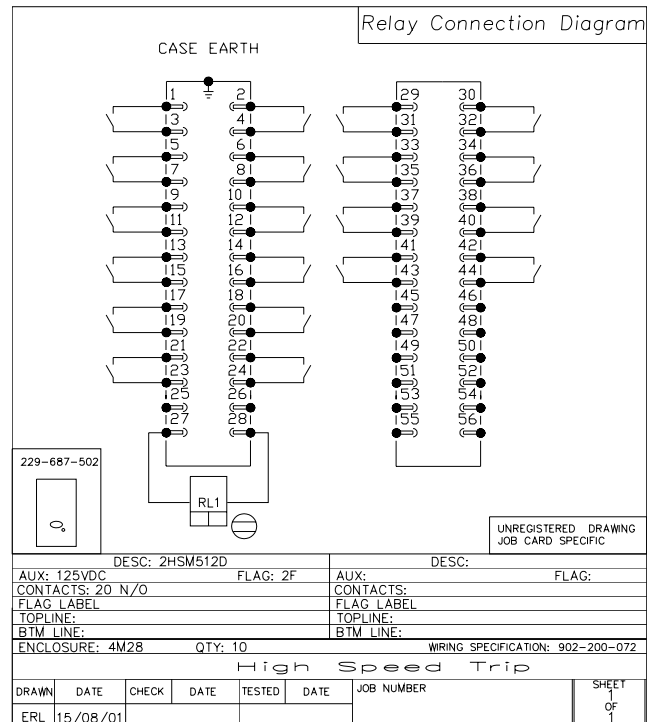

Application

The operating element for the 6R MATRIX Auxiliary Relay functional elements are designated 6RM & are based on our 6R Series relays.

The type 6RM Series elements are low burden auxiliary relays which can be used where a scheme demands several contacts for event recording, alarm initiation, contact logic arrangements, etc.

The relay can be supplied fitted with heavy duty contacts & with heavy duty magnetic blow-outs fitted.

Contacts are constructed from silver / copper alloy, shaped & positioned to ensure very reliable, low resistance operation. Over travel of the contacts during each operation causes a wiping action ensuring a clean "make".

Heavy duty make, break & changeover contacts & heavy duty contacts fitted with magnetic blow-outs are available in various combinations. See table 2 below.

Heavy duty contacts fitted with magnetic blow-out are recommended for breaking heavy or highly inductive DC loads. When these are fitted, the number of contacts available may be reduced.

A 2TM649 adjustable time delay element may also be added to any of the size A 6RM elements.

Flag Indicators

Each relay element is supplied with a flag (target) indicator. The indicator consists of a high visibility solid dayglow orange mechanical flag which drops on energisation or de-energisation.

Resets

Resetting of flags & contacts may be either manual at the relay panel or electrical via a remote signal or both. The provision to separately reset the flag & contacts is also possible.

Electrical Reset Function

COMBINED CONTACT / FLAG OPERATION & RESET 6RM210

With these types the flag & contacts operate & reset together. i.e.

When the relay is operated the flag changes state & the contacts latch. Both the flag & contacts are reset if either the reset button is pressed or the electrical reset coil is energized.

COMBINED CONTACT / FLAG OPERATION & INDEPENDENT RESET 6RM211

With these types the flag & contacts operate together but may be reset independently. i.e.

When the relay is operated the flag changes state & the contacts latch. The contacts only are reset if the electrical reset coil is energized or the contact reset button is pressed. In both cases the flag is not reset.

The flag can only be reset if the independent flag reset button is pressed.

Coil Operating Power

Relay elements may be specified with 1W or 2W operating power. 2W coils have the advantage of faster operation for armature operated contacts but obviously generate more heat when continuously energized. A second advantage which is particularly useful in high humidity climate installations is that the thicker gauge copper wire used in 2W coils is less susceptible to corrosion & going open circuit.

6RM Auxiliary Elements

Operating Times

INSTANTANEOUS OPERATING TIMES (6RM2xx Series)

Contact Stack	Pick up* 1W coil	Pick up* 2W coil	Drop out* 1W coil	Drop out* 2W coil
1 N/O	25	22	34	35
2 N/O	32	25	24	25
3 N/O	35	25	18	19
4 N/O	40	30	14	15
6 N/O	50	35	12	13
9 N/O	65	45	10	11
1 N/C	25	22	38	38
2 N/C	40	25	25	26
3 N/C	52	35	20	21
4 N/C	62	40	18	19
6 N/C	70	52	13	14
1 C/O	35	22	26	27
2 C/O	45	25	20	21
3 C/O	60	40	13	14
4 C/O	75	45	12	13
6 C/O	90	50	10	11
7 C/O	110	55	9	10

Table 2

* NOTES ON OPERATING TIMES:

1. Tolerance on stated operate times: +/-10%
2. Operate times are in ms & refer to armature operated contacts at nominal stated coil operating voltage.
3. For flag operated contacts operate time is typically 60ms & is independent of the coil power.
4. 1W nominal coils are used as the default coil specification.

OPERATING TIMES WITH TIME DELAY SLUGS FITTED

DELAY ON DROP OFF Heel end slugs (HES)
Heel end slugs can be specified to provide delayed drop out times of up to 300ms. The more contacts specified the faster the drop out time.

DELAY ON PICK UP Armature end slugs (AES)
Armature end slugs can be specified to provide delayed pick up times of up to 150ms. The more contacts specified the slower the pick up time.

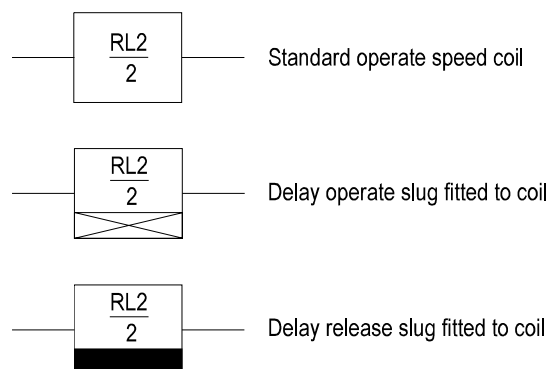

6RM Standard Versions

- ◆ There are 9 basic 6RM versions without a slug time delay.
- ◆ There are 4 versions with a slug delay release function.
- ◆ There are 9 versions with a slug delay operate function.

All versions are defined by the operation of the contact & flag reset mechanism & may be specified with contact configurations as described in table 2.

6R Element Part Numbers Timing Function									Maximum Contacts		
No Time Delay	Delay Release	Delay Operate	Contact	Flag	Element Size	Minimum Case	Magnetic Blowouts		Heavy Duty		
							M or B*	M or B*			
							1	2			
6RM201	6RM301	6RM401	SR	NF	A	2M28-S-1A	4	6			
							B	2M28-S-1B	10	13	
							D	4M56-S-1D	20	20	
6RM202	6RM302	6RM402	SR	HR	A	2M28-S-1A	4	6			
							B	2M28-S-1B	10	13	
							D	4M56-S-1D	20	20	
6RM203	6RM303	6RM403	SR		A	2M28-S-1A	4	6			
							B	2M28-S-1B	10	13	
							D	4M56-S-1D	20	20	
6RM204	6RM304	6RM404	H/SR	HR	A	2M28-S-1A	1SR / 1HR	2SR / 2HR			
							D	4M28-S-1D	2SR / 2HR	4SR / 4HR	
6RM206	-	6RM406	HR		A	2M28-S-1A	4	6			
							B	2M28-S-1B	10	13	
							D	4M56-S-1D	20	20	
6RM207	-	6RM407	ER		A	2M28-S-1A	1	2			
							B	2M28-S-1B	9	12	
							D	4M56-S-1D	19	19	
6RM208	-	6RM408	ER	HR	B	2M28-S-1B	9	12			
							D	4M56-S-1D	19	19	
6RM210	-	6RM410	H/ER		A	4M28-S-1A	1	2			
							B	2M28-S-1B	9	12	
							D	4M56-S-1D	19	19	
6RM211	-	6RM411	H/ER	HR	B	2M28-S-1B	9	12			
							D	4M56-S-1D	19	19	

Table 3

KEY: H/ER - Hand / electrical reset SR - Self reset HR - Hand reset
H/SR - Hand / self reset ER - Electrical reset C/F - Consult factory
M - Make (N/O) contacts B - Break (N/C) contacts NF - No flag

*C/O - Changeover contacts may be specified but EACH C/O contact replaces 1.5 M or B contacts.

EXAMPLE: 6RM206-A1 represents an auxiliary relay with a maximum of 4 heavy duty M or B (Magnetic blowouts fitted), hand reset contacts.

As the relay element is a size A, two of these elements may be fitted in a size 2M28-S-2A case.

Application

The Series 2TM649 Time Delay on energisation relays are suitable for utility grade protection & control schemes where accurate & consistent time delays are required.

The 2TM649 version used in the MATRIX Relay system occupies the same space as a size A element & may be used to provide a time delay function when combined with any size A 6RM element. The two A elements when combined consume the space of a size B element.

Minimum case size: 2M28-S-1A

It is possible to combine a 2TM649 size A element with a size B 6RM element but the result must be considered as a size D element.

Minimum case size: 4M28-S-1D

Operation

Combining the 6RM & 2TM649 elements provides the proven rugged reliability of an electro-mechanical relay driven from an electronic ripple count type timer.

Pulses from an on-chip oscillator are fed into a ripple counter which is programmed to give an output after a pre-set (binary) count is reached. Time setting is achieved by a dial mounted potentiometer located on the front panel which adjusts the oscillator frequency. The output of the ripple counter (2TM649) drives the heavy duty electromechanical relay (6RM) via a transistor switch.

This technique gives good repeatability & fast reset characteristics, although delays are provided which prevent spurious resetting for short term supply dips. Power failures of less than 20 milliseconds duration will not affect the operation of the timer which will continue timing out.

Technical Data

ACCURACY

+/-5% of max- setting

REPEATABILITY

+/-2% of setting **Note:** Repeat accuracy in particular is greatly improved when ambient temperature conditions & supply voltages are stable.

SUPPLY VOLTAGE

24, 32, 48, 110, 125, or 250V DC nom. with allowable variation of 75-120% of nominal.

BURDEN (110V AC unit)

3VA (approx.) during timing
5VA (approx.) whilst output relay is energized.

INSULATION WITHSTAND

In accordance with IEC 255-5:
2KV RMS between input & frame, output & frame, & output & input. 1.2/50 5KV impulse between each terminal & earth, between circuits not normally connected together & between terminals of the same circuit.

6R RELAY CONTACT RATINGS

Refer 6RM data.

NOISE IMMUNITY

Withstands the high frequency interference test detailed in IEC 255-22-1.

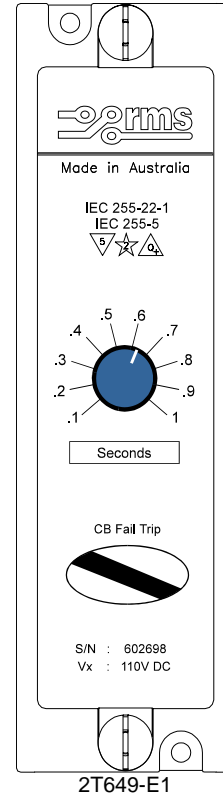

Ordering Codes

The 2TM649 is available with five standard time delay ranges & seven standard operating voltages as follows. These must be specified when ordering as follows:

Generate the required ordering code as follows: e.g. 2TM649-D2

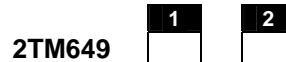

1 NOMINAL OPERATE VOLTAGE

A	24V DC	D	110V DC
B	32V DC	E	125V DC
C	48V DC	F	250V DC

2 TIME RANGE

1	0.1 to 1s	4	3 to 30s
2	0.3 to 3s	5	10 to 100s
3	1 to 10s		

ELEMENT TEXT (Optional)

Element part number is used as the default

--	--	--	--	--	--	--	--	--	--	--	--

Application

The 1TM Series Relays provide fail safe supervision of CB trip circuits. Three models are available depending on the degree of supervision required & wiring configuration.

Supervision	Model Number			
	1TM10	1TM11	1TM12	1TM13
CB 52a contact	Yes	No	Yes	No
CB 52b contact	Yes	No	Yes	No
Trip supply	Yes	Yes	Yes	Yes
Trip coil continuity	Yes	No	Yes	No
Trip wiring continuity	Yes	No	Yes	No
Trip relay circuit	No	No	No	Yes

Table 4

The relay can be supplied fitted with heavy duty contacts & with magnetic blow-out fitted.

A significant safety feature is the fitting of internal resistors to limit the trip coil current to well below the circuit breaker trip coil operate current, should the relay be accidentally short circuited. Additionally magnetic blowouts can be fitted to enhance contact switching performance of DC loads. Relays can also be supplied with additional alarm contacts.

STANDARD SUPERVISION RELAYS AVAILABLE

Relay Type	Flag	Element Size	Case	Alarm Contacts
1TM10	Hand reset	B	2M28	2 C/O
1TM11	Hand reset	B	2M28	2 C/O
1TM12	Hand reset	D	4M28	2 C/O
1TM13	Hand reset	B	2M28	2 C/O

Table 5

6R RELAY CONTACT RATINGS

Refer 6RM data.

INSULATION WITHSTAND in accordance with IEC 255-5:
2KV RMS & 1.2/50 5KV impulse between:

- ◆ all input terminals & frame
- ◆ all output terminals & frame
- ◆ all input & output terminals
- ◆ each input group
- ◆ each output group

1TM Trip Circuit Supervision Elements

1TM10 Operation Trip Circuit Supervision Relay

The operating element of the 1TM10 comprises a single 6R heavy duty attracted armature control relay with two operating coils wound on a single core.

Supervision is active with the circuit breaker in the open or closed position via the 52a & b auxiliary contacts.

Under healthy conditions, with the CB in the closed position, winding 1 is energized & if the trip coil becomes open circuited or the supply fails, the relay will drop out initiating the local visual indicator & output contacts. Similarly, when the CB is in the open position, both coil windings 1 & 2 are energized enabling the relay to detect failure of the trip circuit coil or supply in the same manner as if closed. Once operated the electro-mechanical alarm flag must be hand reset.

The relay element is fitted with a slug to provide a delay of 300ms (approx.) on de-energisation preventing a false alarm due to voltage dips in the supply rail, or the normal delays in the tripping operation, when the first coil winding is momentarily short circuited by the protection trip contact. If the protection trip contact should fail to reset, due to a failure of the circuit breaker tripping mechanism for example, the relay drops out initiating the local visual alarm indicator & output contacts.

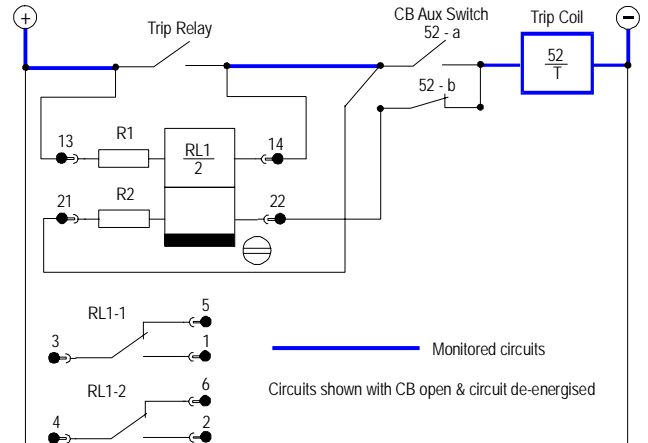

CIRCUIT RESISTANCE & BURDEN

The 1TM10 circuit design is optimized to minimize the supervision current in the CB trip coil to avoid the possibility of nuisance tripping. The total series resistance provided by R1 & RL1 - winding 1 is tabulated below. Resistance of the CB coil must be much less than this figure to ensure adequate supervision current flows through the 1TM10 element under normal conditions.

Nominal supply	~Resistance (ohms)	Burden * (Watts)
32V DC	2,200	<0.6
48V DC	3,100	<0.9
110V DC	7,400	<1.7
125V DC	7,400	<2.2

TRIP SUPPLY BURDEN

* Actual operating burden is dependent on the CB coil resistance.

FLAG OPERATION

Each relay element is supplied with a flag (target) indicator. The indicator consists of a high visibility solid dayglow orange mechanical flag.

Operation: Drops on coil de-energisation.
Reset: Hand reset.

1TM Trip Circuit Supervision Elements

1TM11 Operation Trip Circuit Supply Supervision

The operating element of the 1TM11 comprises a single 6R heavy-duty attracted armature control relay with a single operating coil & delay slug. The relay is normally operated to indicate a healthy trip circuit supply while a slug is fitted to provide a delay on drop out & avoid nuisance tripping due to transients.

Under healthy conditions the coil is energized & if the supply fails, the relay will drop out after a short time delay (300ms approx.), to initiate a supply fail alarm.

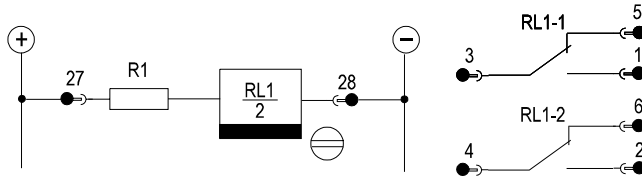

Contacts shown with CB Open & circuit de-energised

CIRCUIT RESISTANCE & BURDEN

The 1TM11 circuit design is optimized to minimize the supervision current to minimize the burden on the supervised supply. The total series resistance provided by R1 & RL1 is tabulated below.

Nominal supply	~Resistance (ohms)	Burden (Watts)
32V DC	1,090	<1
110V DC	8,100	<1.5
125V DC	8,100	<2
250V DC	14,700	<4.5

FLAG OPERATION

Each relay element is supplied with a flag (target) indicator. The indicator consists of a high visibility solid dayglow orange mechanical flag.

Operation: Drops on coil de-energisation.
Reset: Hand reset.

1TM12 Operation Trip Circuit Supervision Relay

The operating element of the 1TM12 comprises three 6R heavy-duty attracted armature relays as shown below.

Supervision is active with the circuit breaker in the open or closed position via the "a & b" CB auxiliary contacts.

Under healthy conditions, with the CB in the closed position, relay 1 & 2 are energized & if the trip coil becomes open circuited or the supply fails, relay 2 will drop out causing alarm relay 1 to drop out & initiate the local visual indicator & output contacts. Similarly, when the CB is in the open position, relays 1, 2 & 3 are energized enabling the relay to detect failure of the trip circuit coil or supply in the same manner as if closed. Once set the alarm relay flag must be hand reset. If the protection trip contact operates relay 1 will drop out after a 300ms (approx.) delay. If the CB auxiliary contact has not opened causing relay 2 not to pick up within this time delay then alarm relay 3 will drop out.

Both relay 2 & 3 elements are fitted with slugs to provide a delay of 300ms (approx.) on de-energisation to prevent false alarms due to voltage dips in the supply rail, or the normal delays in the tripping operation. If the protection trip contact should fail to reset, due to a failure of the circuit breaker tripping mechanism for example, the relay drops out initiating the local visual alarm indicator & output contacts.

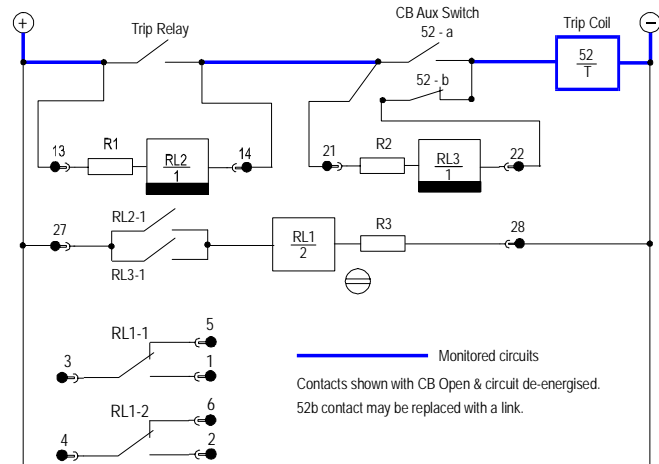

Contacts shown with CB Open & circuit de-energised.
52b contact may be replaced with a link.

CIRCUIT RESISTANCE & BURDEN

The 1TM12 circuit design is optimized to minimize the supervision current in the CB trip coil to avoid the possibility of nuisance tripping. The total series resistance provided by R1 & RL2 is tabulated below. Resistance of the CB coil must be much less than this figure to ensure adequate supervision current flows through the 1TM12 element under normal conditions.

Nominal supply	~Resistance (ohms)	Burden * (Watts)
32V DC	1,090	<1
110V DC	8,100	<1.5
125V DC	8,100	<2
250V DC	14,700	<4.5

TRIP SUPPLY BURDEN

* Actual operating burden is dependent on the CB coil resistance.

ALARM CIRCUIT BURDEN

Allow a nominal 1 Watt for the alarm relay RL1 which is normally energised under healthy trip circuit conditions.

FLAG OPERATION

Each relay element is supplied with a flag (target) indicator. The indicator consists of a high visibility solid dayglow orange mechanical flag.

Operation: Drops on coil de-energisation.
Reset: Hand reset.

1TM Ordering Codes

1TM13 Operation Trip Relay Coil Supervision

The 1TM13 relay is designed to supervise the trip circuit of high burden latching tripping relays such as the 2HSM514 relay element.

The operating element comprises a single 6R heavy-duty attracted armature control relay. It has two dropping resistors R1 & R2 of equal ohmic value, connected in series with the coil.

Under healthy conditions the relay coil is energized via the dropping resistor R1 as shown below (Tripping relay circuit). If the circuit being supervised becomes open circuit or if the supply fails, the relay will become de-energized & an alarm is given (2 C/O contacts & flag indication).

To prevent the alarm being given when the circuit being supervised is operated the relay coil is maintained via the dropping resistor R2. For this purpose, an additional normally open contact is required from the tripping relay as depicted below:

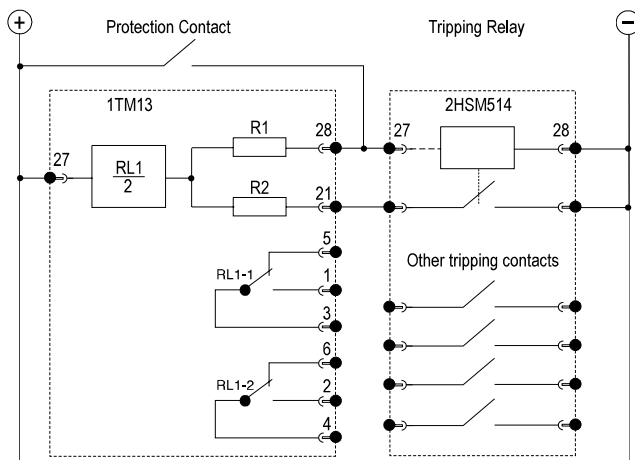

CIRCUIT RESISTANCE & BURDEN

The 1TM13 circuit design is optimized to minimize the supervision current in the tripping relay coil to avoid the possibility of nuisance tripping. The total series resistance provided by the combination of RL1/R1 & RL1/R2 is tabulated below. Resistance of the CB coil must be much less than this figure to ensure adequate supervision current flows through the 1TM13 element under normal conditions.

Nominal supply	~Resistance (ohms)	Burden* (Watts)
32V DC	2,200	<0.6
48V DC	3,100	<0.9
110V DC	7,400	<1.7
125V DC	7,400	<2.2

TRIP SUPPLY BURDEN

* Actual operating burden is dependent on the tripping relay coil resistance.

FLAG OPERATION

Each relay element is supplied with a flag (target) indicator. The indicator consists of a high visibility solid dayglow orange mechanical flag.

Operation: Drops on coil de-energisation.
Reset: Hand reset.

Generate the required ordering code as follows:
e.g. 1TM10-D2

1TM

1

2

3

1 RELAY FUNCTION

Specify relay functional number from table 5.

2 NOMINAL OPERATE VOLTAGE

- | | |
|----------|-----------|
| A 24V DC | D 110V DC |
| B 32V DC | E 125V DC |
| C 48V DC | |

3 CONTACT DUTY

- 1 Heavy duty contacts – magnetic blowouts fitted
- 2 Heavy duty contacts

ELEMENT TEXT (Optional)

Element part number is used as the default

M Series Case System

The M Series case range has been specifically designed to meet the demanding & varied requirements for applications in power utility sub-station environments. The standard 4U high 19 inch rack mounting modular configuration simplifies panel design & installation.

Mounting points & overall panel dimensions meet international standards such that the cases may be interchanged with other similar types available on the market.

The MATRIX-S version was released in mid August 2005 with the length reduced by 18mm to improve compatibility with shallow cubicles.

Care should be taken when ordering spare relay modules to ensure compatibility with existing units.

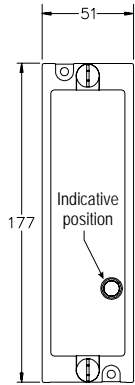

Front view

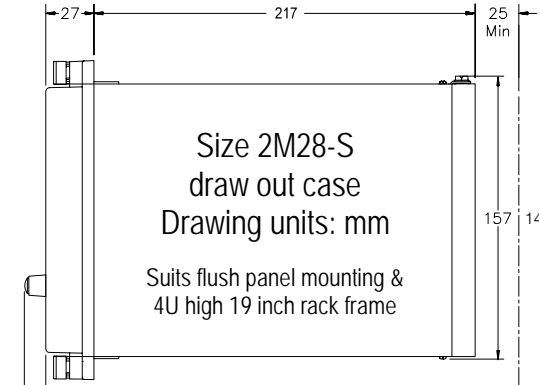

Side view

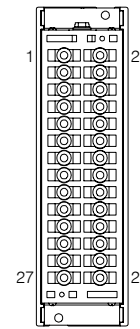

Terminal layout

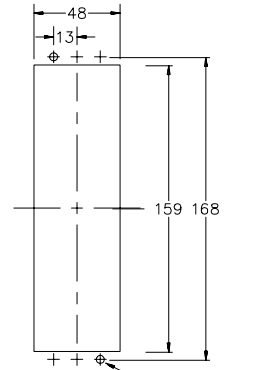

Panel cut out

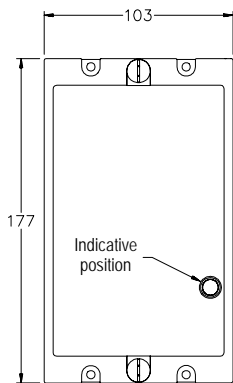

Front view

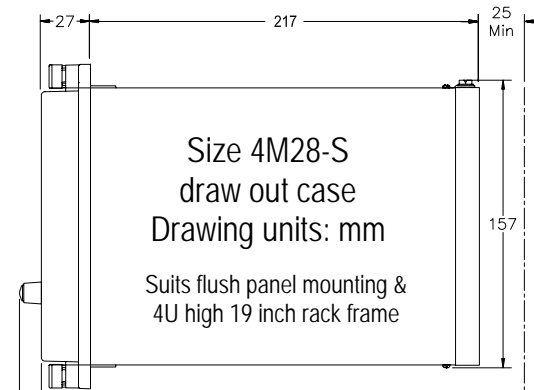

Side view

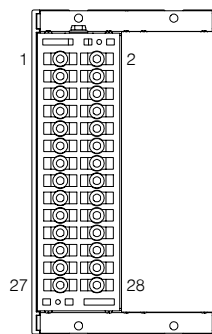

Terminal layout

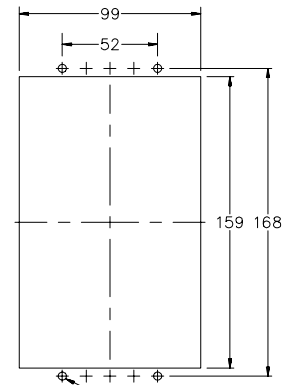

Panel cut out

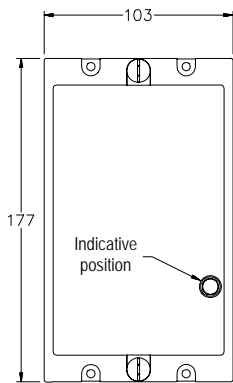

Front view

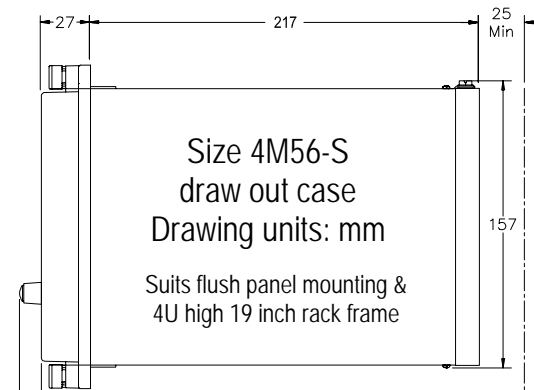

Side view

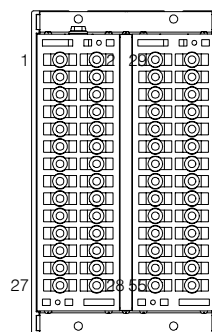

Terminal layout

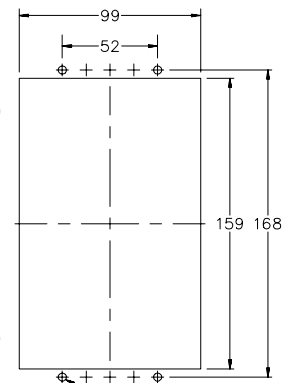

Panel cut out

Technical Data

CURRENT RATINGS

CT terminals:	20A	continuous
	400A	1s
Other terminals:	10A	continuous
	200A	1s

VOLTAGE RATINGS

All circuits & terminals:	600V AC	continuous
	350V DC	continuous

AUXILIARY INSULATION WITHSTAND

In accordance IEC 255-5:
 2KV RMS between all terminals & all terminals & frame.
 1.2/50 5KV impulse between all terminals & all terminals & frame.

IP RATING

IP5X category 2 dust protected and IP4X for solid ingress to IEC60529.

M Series Case Accessories

Refer to the M Series Technical Bulletin:

<http://www.rmspl.com.au/mseries.htm>

- Sub rack mount frames
- Blanking plates
- Mounting screw kits
- Termination ring lugs
- Stud terminal kits
- Semi projection mount kits
- Earth bars

Case Ordering Codes

Generate the required order code as follows: e.g. 2M28-S-1B

Order Code				
1		2		3
	M		- S -	

1 CASE SIZE

- 2 Size 2
- 4 Size 4

M M SERIES CASE

2 NUMBER OF TERMINALS

- 28 28 Terminals
- 56 56 Terminals (Size 4 case only)

S SHORT CASE VERSION

3 RELAY ELEMENTS PER CASE

- 1A One A relay element (Size 2 case only)
- 1B One B relay element (Size 2 case only)
- 1D One D relay element (Size 4 case only)
- 2A Two A relay elements (Size 2 case only)
- 2B Two B relay elements (Size 4 case only)
- 3A Three A relay elements (Size 4 case only)
- 4A Four A relay elements (Size 4 case only)
- 1TB One time delayed B element (Size 2 case only)
- 2TB Two time delayed B elements (Size 4 case only)
- 1TD One time delayed D element (Size 4 case only)

Case Mounting Screws

RELAY PANEL/RACK MOUNTING SCREWS

P/N 290-406-151A

4 X M4 self threading screws
 Use for RMS "D", "E" & "M" Series relay cases

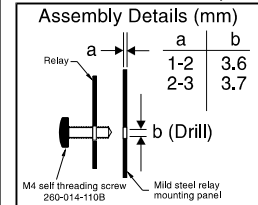

M Series cases may be flush mounted to mild steel panels up to 3mm thick using the M4 self threading screws provided with the case. Panel mounting is simplified due to the location of the fixing screws at the front face of the relay. Alternatively the cases may be 19 inch rack mounted using a 4U high sub rack. The M4 self threading screws are suitable for application with the RMS type 4M800K1 sub

Australian Content

Unless otherwise stated the product(s) quoted are manufactured by RMS at our production facility in Melbourne Australia. Approximately 60% of our sales volume is derived from equipment manufactured in house with a local content close to 90%. Imported components such as semi-conductors are sourced from local suppliers & preference is given for reasonable stock holding to support our build requirements.

Quality Assurance

RMS holds NCSI (NATA Certification Services International), registration number 6869 for the certification of a quality assurance system to AS/NZS ISO9001-2000. Quality plans for all products involve 100% inspection and testing carried out before despatch. Further details on specific test plans, quality policy & procedures may be found in section A4 of the RMS product catalogue.

Product Packaging

Protection relays are supplied in secure individual packing cardboard boxes with moulded styrene inserts suitable for recycling. Each product & packing box is labeled with the product part number, customer name & order details.

Design References

The products & components produced by RMS are based on many years of field experience since Relays Pty Ltd was formed in 1955. A large population of equipment is in service throughout Australia, New Zealand, South Africa & South East Asia attesting to this fact. Specific product & customer reference sites may be provided on application.

Product Warranty

All utility grade protection & auxiliary relay products, unless otherwise stated, are warranted for a period of 24 months from shipment for materials & labour on a return to factory basis. Repair of products damaged through poor application or circumstances outside the product ratings will be carried out at the customer's expense.

Standard Conditions of Sale

Unless otherwise agreed RMS Standard Terms & Conditions (QF 907) shall apply to all sales. These are available on request or from our web site.



Relay Monitoring Systems Pty Ltd

6 Anzed Court, Mulgrave, Victoria 3170, AUSTRALIA

Tel: 61 3 9561 0266 Fax: 61 3 9561 0277 Email: rms@rmspl.com.au Web: www.rmspl.com.au