

IF IN DOUBT ASK
DO NOT SCALE

ABBREVIATIONS	
I-	CURRENT INPUTS
BI-	BINARY INPUTS
BO-	BINARY OUTPUTS
CO-	CHANGE OVER BINARY OUTPUT CONTACTS
NO-	NORMALLY OPEN BINARY OUTPUT CONTACTS
NC-	NORMALLY CLOSED BINARY OUTPUT CONTACTS

COMMUNICATIONS IDENTIFICATION	
COM1	RS485 (ON BLOCK 'B' TERMINALS 14,16,18 & 20)
COM2	USB TYPE 'B' PORT (ON RELAY FRONT LABEL)

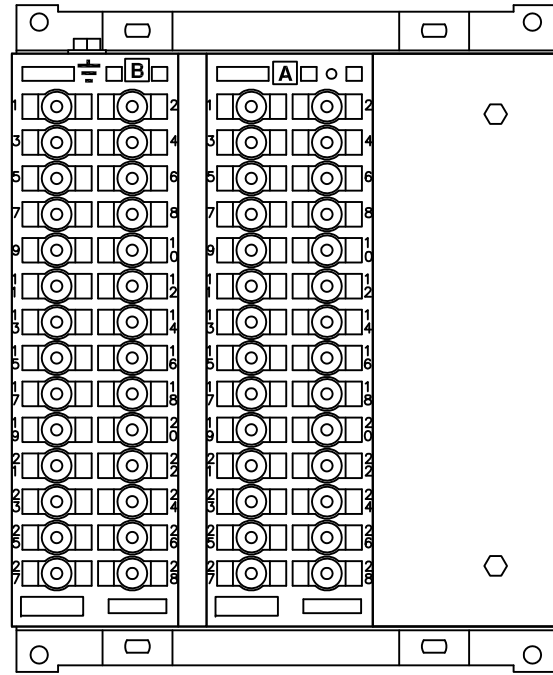

RELAY VIEWED FROM REAR

NOTES

1) TERMINALS RECOMMENDED ARE PRE-INSULATED & MUST BE CRIMPED USING APPROVED TOOLING. AMP PIDG OR PLASTI GRIP FUNNEL ENTRY (RING TONGUE) FOR M4 FIXING STUD.

SUPPLIER	PART NUMBER	CABLE SIZE
AMP	342103	0.25-1.6mm ²
AMP	342143	1.0-2.6mm ²

OR ANY OTHER MANUFACTURERS EQUIVALENT TERMINAL.

2) FOR OUTLINE & PANEL DRILLING, SEE 2995X10006 (A4).

3) CONNECTIONS TO THIS COMMUNICATIONS FACILITY IS BY SCREENED, TWISTED PAIR CABLE, ON SITE. WHEN WIRING OTHER FACILITIES ENSURE THAT THESE TERMINALS ARE NOT OBSCURED BY OTHER WIRE RUNS.

4) CONTACTS SHOWN THUS  ARE INTERNAL TO THE RELAY CASE ASSEMBLY AND CLOSE WHEN THE RELAY CHASSIS IS WITHDRAWN FROM THE CASE.

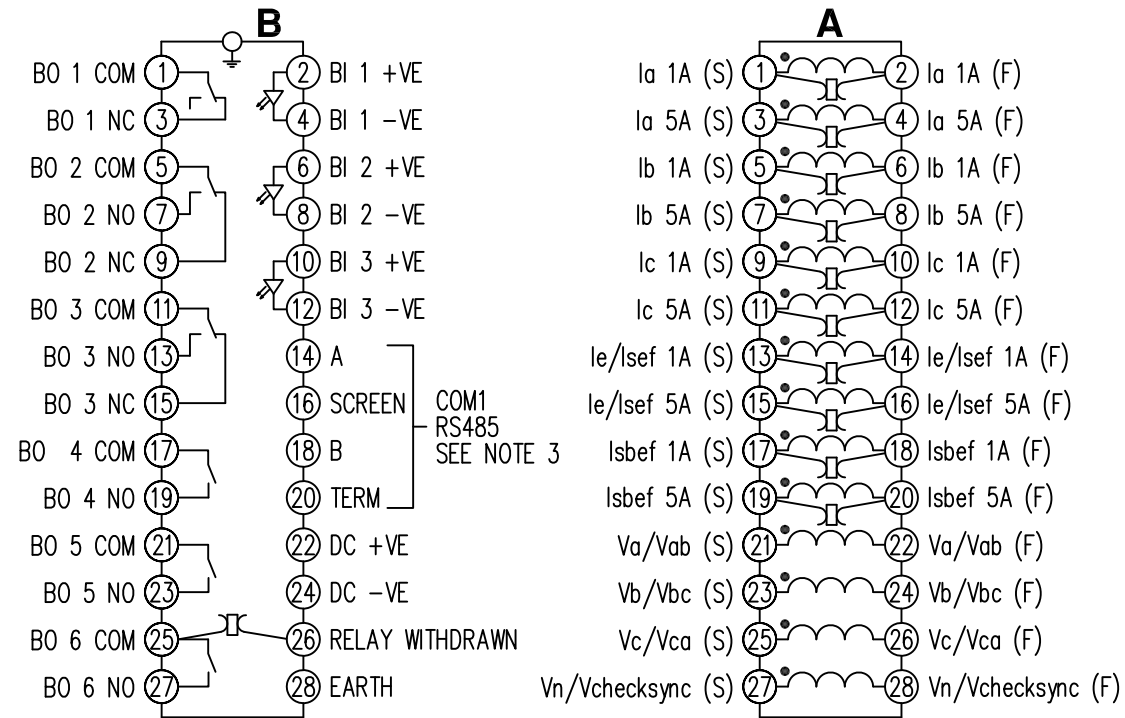

COMMS
BLANKING
PLATE

**NOT SUBJECT TO UPDATE
ONCE COPIED / PRINTED
OR DOWNLOADED**

MATERIAL:

Dimensions in millimetres : Surface texture in micrometres.
Machine where marked ✓
For explanation of dimensions, tolerances, notes etc. see B.S.308.
Limit on untoleranced unmachined dimensions ± _____
Limits on untoleranced machined dimensions to B.S.4500;
i.e. up to 6±0.1; over 30 to 120±0.3; over 315±0.8;
over 6 to 30±0.2; over 120 to 315±0.5;
General unmachined angular tolerance ± _____

Finish:

Title:
TERMINAL ID & WIRING DIAGRAM FOR RM PLATFORM
(5I+4V,3BI,2CO,3NO,1NC,RS485) E6 CASE

First used on:

Treatment:

SIEMENS PROTECTION DEVICES LTD.

Original Scale.

NTS

Drq. No.

2435W40014

1	04/09/07	CHANGE
ISSUE	DATE	NOTED