

Features

- 5 kV Isolation for application as Intertrip SEND relay
- Rugged modular construction
- High reliability double action contacts for high operate speed and low bounce
- Intertrip SEND with user selectable low or high burden operation to withstand capacitor discharge test
- High speed operation
- Configurable operate period ¼ sec to 4 sec, ¼ sec steps
- 5 heavy duty contacts available in a wide range of Make and Break combinations
- High visibility electro-mechanical flag indication available
- Rated operate voltages available for 30/32, 48, 110, 125, 220, 240 or 250 Volts DC nominal auxiliary supplies
- Rack or flush mounting
- Compact size 2 draw out case
- M4 screw terminals
- Optional gold plated contacts suitable for low currents
- Optional custom labeling
- Optional relay operate LED
- Simple to specify and order

Application

Inter-tripping over copper pilots using a DC signal is commonly employed. The PR5 Series Relays are intended for the remote control of switchgear & associated equipment via pilot wires on which induced AC voltages could cause false tripping.

The PR5-S Intertrip SEND relay is used to interface trip circuit contacts, or other conventional protection relay contacts to the pilot wire with suitable electrical isolation for the feeder voltage level. The fast pick-up time (<8ms), ensures total intertrip time is kept to a minimum.



PR5-S Intertrip SEND Relay

Operation

Made in Australia

The operating element of the PR5-S Series is based on the patented Alpha-12 high speed, heavy duty attracted armature control relay.

The PR5-S Intertrip SEND element is used to apply a DC control voltage to the pilot wire for a fixed interval as set between 250 ms and 4 Seconds.

An auxiliary supply is provided to the relay so that it can 'seal in' for the defined timeout period regardless of whether the Trip/Operate is removed during that period. For system integrity should the auxiliary supply fail, the relay is designed such that the relay timeout and rearm lockout will be maintained and only the 'seal in' feature is lost.

For added system integrity, the relay also provides a lock out period on re arming to avoid false repeat operates due to momentary switching disruptions

An optional LED or armature flag may be specified to indicate the Intertrip send event.

A mechanical flag indicator option is also available which drops on pick up. Manual & self reset version available.

Front Panel Layout

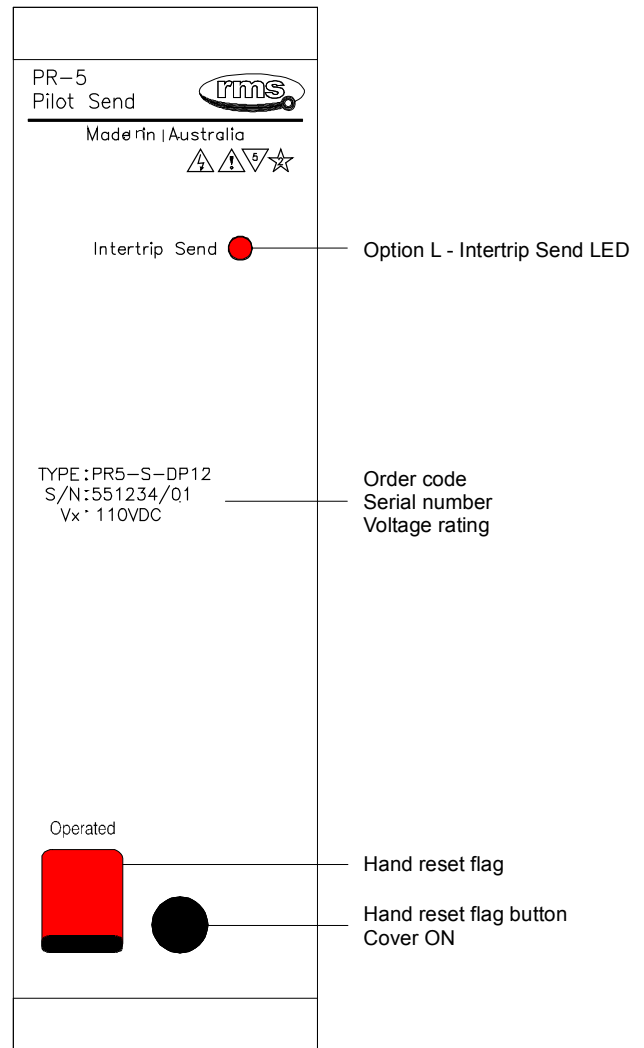

Figure 1:
Front panel layout depicting flags, reset buttons & option positions

MODEL SPECIFIC SPECIFICATIONS

Refer to the following sections in this publication:

- PR5-S Pilot wire intertrip send relay

COMMON SPECIFICATIONS

Refer to the following sections in this publication:

- General Specifications
- Case Details
- Ordering codes
- Accessories

PR5-S Intertrip Send Relay

LOW BURDEN SETTING

The low burden configuration is suitable for applications where immunity to capacitance discharge and high minimum operation currents are not required. Suitable for MV applications where the DC battery supply capacity is limited.

HIGH BURDEN SETTING

In this configuration the relay is suitable for application in high security circuit breaker tripping circuits and in particular where the initiating contact may be remote from the relay. The high burden can also be used to facilitate the satisfactory operation of external series elements provided the time delayed cut off option is specified - Refer to the section 'Operation of Series Elements'.

The high burden configuration provides maximum immunity to electrical disturbance and noise.

High burden tripping relays are designed to withstand the 10uF capacitor discharge test such that the relay will not operate when a 10uF capacitor charged to 120% of the nominal operating voltage is applied across the operate input of the relay.

OPERATING BURDEN CONFIGURATION

PR5-S intertrip send relays may be set by the user for low burden or high burden operation. This is achieved by withdrawing the relay module from the case and changing the position of a PCB link, as depicted in figure 2.

The burden setting link is located at the bottom front of the draw out module and is readily accessible to the user for checking and changing to meet specific system requirements.

Unless otherwise specified all PR5-S model relays are factory set and shipped in high burden configuration.



Figure 2: Link for setting operating burden

The link is shown fitted in the low burden (LB), position.

LB = Low burden operation.

HB = high burden operation – default factory position.

FLAG INDICATORS

The PR5-S offers two types of mechanical flags. These consist of a high visibility, solid, day glow orange indicator which become visible upon initiation of an intertrip SEND pulse. The relay can be ordered with either, both or no flags fitted. Reverse acting flags are also available.

Note: There is no impact on the contact operate speed or relay performance when these flags are fitted.

ARMATURE FLAG

The armature flag is connected to the relay armature and therefore always indicates the position of the contacts. The standard armature flag becomes visible when the relay is operated. If latching contacts are specified the self reset flag will remain visible in the latched condition until the relay is reset.

INDEPENDENT HAND RESET FLAG

This flag is independent of the self reset flag and operates when the intertrip send is initiated and remains visible until it is manually hand reset using the reset button located on the front of the relay. Note that this flag can only be reset once the 2s intertrip send pulse has timed out and the contacts reset.

MODEL DESIGNATION

Intertrip send relay: PR5-S

OPERATING VOLTAGE

Guaranteed operation between 50% and 120% of nominal rated DC operating voltage.

For 30/32 V DC rated models the operating range is from 50% of the lower rating to 120% of the higher rating.

RESET VOLTAGE

Self reset relays will reset at not less than 5% of nominal rated operate voltage. Reset typically occurs at 20% of nominal.

OPERATING BURDEN

Average burden during pick up at nominal

Low burden configuration:	50 W	Maximum
High burden configuration:	100 W	Minimum
	150 W	Maximum

OPERATED BURDEN

(Burden after pick up at nominal)
Initiate applied: 5 W maximum
+1 W for LED option

Initiate removed: Zero

Auto Economizing delay: 50 +/- 10 ms

AUXILIARY BURDEN

Auxiliary supply burden:

Prior to relay pick up and after relay has timed out: 1 W

During time out if initiate removed: 5 W maximum
+1 W for LED option

TIME DELAYED CUT OFF

Timing accuracy: $\pm 10 \text{ ms} \pm 5\% \text{ of } T_{\text{set}}$

T_{set} = selected timing period of 250 ms to 4s

MINIMUM OPERATING CURRENT

Low burden setting: 50 mA minimum
High burden setting: 100 mA minimum

COIL THERMAL RATING

All operate, reset and time delayed circuits are designed to withstand continuous application of 120% of the nominal rated voltage.

The high speed operate coil element (150 W max.) has a thermal rating of 30 seconds, however the PR5-S intertrip send relays automatically economizes within 60 ms of operation to provide inherent thermal protection.

OPERATING TIME

Application of the PR5-S relay ensures fast operation of less than 8 ms. The unique patented design and topology ensures minimal contact bounce

Make contacts: <8 ms to first touch and <9 ms to end bounce at nominal rated operating voltage.

Break contacts: <8 ms transition

Relay Timing

TIME OUT PERIOD SELECTION SWITCHES

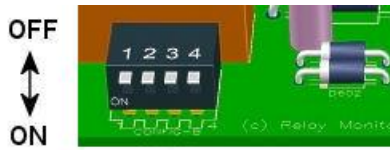

SW50-4	SW50-3	SW50-2	SW50-1	TIME
OFF	OFF	OFF	OFF	0.25s
OFF	OFF	OFF	ON	0.50s
OFF	OFF	ON	OFF	0.75s
OFF	OFF	ON	ON	1.00s
OFF	ON	OFF	OFF	1.25s
OFF	ON	OFF	ON	1.50s
OFF	ON	ON	OFF	1.75s
OFF	ON	ON	ON	2.00s
ON	OFF	OFF	OFF	2.25s
ON	OFF	OFF	ON	2.50s
ON	OFF	ON	OFF	2.75s
ON	OFF	ON	ON	3.00s
ON	ON	OFF	OFF	3.25s
ON	ON	OFF	ON	3.50s
ON	ON	ON	OFF	3.75s
ON	ON	ON	ON	4.00s

Nominal Time Out period. SECONDS

SELF RESET CONTACTS

All contacts operate when a voltage in the specified range is applied to the intertrip SEND input and is automatically reset after time out as depicted in timing diagrams 3 and 4.

OPERATE - TIMER INITIATE

The relay commences pull in immediately an Operate signal is provided that can meet the power burden requirements.

The relay does not 'seal in' and the timer does not initiate timing until the relay has fully pulled in.

The Operate signal should be provided for a minimum of 15 ms.

TIMER REARM

The Operate must be removed for >15ms to re-arm the timing circuit before a subsequent intertrip initiate may be applied.

TIMER ACCURACY

The Intertrip timer period selected has an accuracy of better than:

$$\pm 10 \text{ ms} \pm 5\% \text{ of } T_{\text{set}}$$

AUXILIARY SUPPLY

An auxiliary supply must be connected to the relay for the Intertrip time delay and rearm lock out to operate.

Auxiliary supply range: > 50% of nominal
< 120% of nominal

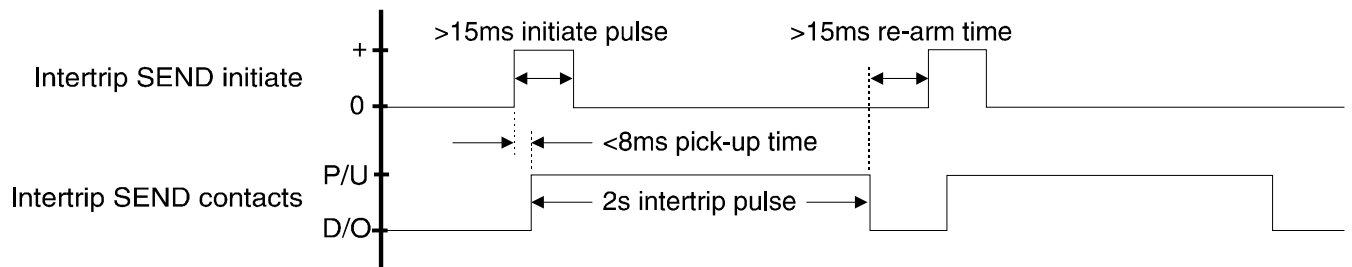

Figure 3: Timing diagram for Intertrip SEND 'pulse' initiate

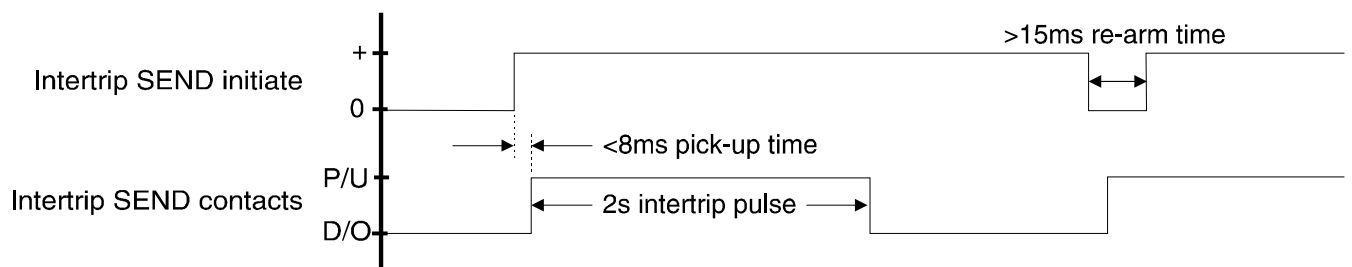

Figure 4: Timing diagram for Intertrip SEND 'latched' initiate

Contact Performance

SELF CLEANING CONTACTS

Contacts are constructed from silver / copper alloy, specially shaped and positioned to ensure very reliable, low resistance operation. Over travel of the contacts during each operation causes a wiping action ensuring a clean 'make' with minimal bounce.

General Specifications

GOLD PLATED CONTACTS

Gold plated contacts are available as an option for very low current switching. Refer ordering code section.

STANDARD CONTACT CONFIGURATION

4 N/O make (M) contacts plus 1 N/C break (B) contact

Alternative contact arrangements from 4M+1B to 1M+4B can be specified in the ordering information section. Contact terminal assignments are defined in table 1.

DOUBLE MAKE / DOUBLE BREAK CONTACTS

Each contact is made up of a double make or double break geometry to increase the isolation between open contacts and increase the current break rating.

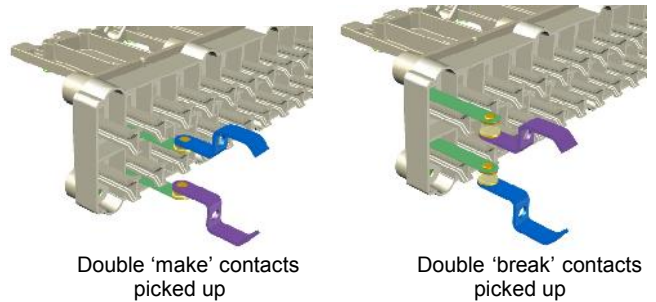

Figure 5: Contact geometry

This geometry also removes the need for internal wiring between case terminals and the relay contacts. This results in four (4) less electrical terminations per contact providing increased system security.

MANUAL RESET MECHANISM

For relays specified with manual reset functions, a reset mechanism is provided on the front panel and cover. Manual reset can be accomplished with the front cover fitted or removed.

Care should be taken to avoid holding the Contact and Armature Flag Hand Reset actuator in the reset position during the presence of a relay operate signal. This action will cause the relay to oscillate between drop-out and pick-up and if this condition is maintained may result in thermal and / or mechanical damage to the device.

COIL OPERATION LED

An optional front panel LED may be specified to indicate when an intertrip send pulse is in progress. This feature can be useful during commissioning. Refer ordering code section.

Contact Tests

CONTACT RATINGS

Make and Carry Continuously

1,250 VA AC resistive Limited at both 660 V and 8 A
1,250 W DC resistive Limited at both 660 V and 8 A

Make and Carry for 3 Seconds

7,500 VA AC resistive Limited at both 660 V and 30 A
7,500 W DC resistive Limited at both 660 V and 30 A

AC Break Capacity

1,250 VA AC resistive Limited at both 8 A and 250 V

DC Break Capacity

100W DC resistive
50W DC inductive (L/R 40 ms) Limited at both 8 A and 250 V

CONTACT OPERATIONAL LIFE

Maximum contact load: >10,000 operations

Mechanical Tests

VIBRATION (SINUSOIDAL) IEC60255-21-1 CLASS I

0.5 gN vibration response	No mal operation
1.0 gN vibration endurance	

SHOCK AND BUMP IEC60255-21-2 CLASS I

5 gN shock response, 11 ms	No mal operation
15 gN shock withstand, 11 ms	
10 gN bump test, 16 ms	

SEISMIC IEC60255-21-3 CLASS I

1 gN seismic response	No mal operation
-----------------------	------------------

MECHANICAL CLASSIFICATION IEC60255-1

Durability at full load 0.1 Hz maximum repetition rate	>10,000 operations
---	--------------------

Climate Tests

TEMPERATURE RANGE IEC60068-2-1/2

Operating:	-10 to +55 °C
Storage:	-25 to +75 °C

HUMIDITY IEC60068-2-78

40 °C and 95% RH non condensing

General Specifications

Electrical Tests

TRANSIENT OVERVOLTAGE IEC60255-5 CLASS III

Between all terminals and earth	5 kV 1.2/50 us 0.5 J
Between independent circuits	5 kV 1.2/50 us 0.5 J

INSULATION COORDINATION IEC60255-5 CLASS III

Between all terminals and earth	5 kV rms for 1 minute
Between independent circuits	5 kV rms for 1 minute
Across normally open contacts	1 kV rms for 1 minute

HIGH FREQUENCY DISTURBANCE IEC60255-22-1 CLASS III

Between all terminals of the same circuit	1.0 kV peak
Between independent circuits	2.5 kV peak
Between independent circuits and earth	2.5 kV peak

FAST TRANSIENT IEC60255-22-4 CLASS IV

Applied directly to operate inputs	4kV peak 100 kHz
Applied directly to all inputs	4kV peak 100 kHz

CAPACITOR DISCHARGE ENA TS 48-4 CLASS ESI 2

Nominal voltage	Capacitor discharge test compliance	
32V DC	Not applicable	
48V DC	PR5-S relays set for high burden Operation. Refer figure 2.	No mal operation for Capacitor discharge: C = 10 uF V = 120% of V _{nominal} (* 275V Maximum)
110V DC		
125V DC		
230V DC*		
240V DC*		
250V DC*		

ELECTROSTATIC DISCHARGE IEC60255-22-2 CLASS III

6kV contact discharge	≤ 5% variation
-----------------------	----------------

RADIO FREQUENCY INTERFERENCE IEC60255-22-3

10V/m, 80 TO 2,700MHz	≤ 5% variation
-----------------------	----------------

CONDUCTED RFI IEC60255-22-6

10V, 0.15 to 80MHz	≤ 5% variation
--------------------	----------------

M SERIES DRAW OUT CASE

The M Series case range has been specifically designed to meet the demanding and varied requirements for applications in power utility sub-station environments. The standard 4U high 19 inch rack mounting modular configuration simplifies panel design and installation.

Mounting points and overall panel dimensions meet international standards such that the cases may be interchanged with other similar types available on the market.

The following standard features are provided:

- Compact size 2M28-S case
- Rack and flush mounting
- Draw out relay module
- Rear M4 screw terminals

Refer to the M Series Technical Bulletin for additional information on case mounting and wiring.

CASE CONSTRUCTION

The outer case is manufactured from zinc coated mild steel providing considerable strength and long term durability. The entire case surface is powder coated to provide corrosion protection and an attractive textured finish. Relay elements are mounted on fabricated fiberglass and acetal components to provide reliable electrical isolation and simple cost effective construction.

TERMINAL RATINGS

20A continuous
200A 1 s

Case Details

TERMINAL BLOCK

The draw out function is made possible through the use of inner and outer terminal blocks, each with silver plated contact fingers to provide high current rating and very low electrical resistance.

A high quality molded inner terminal block is utilized which incorporates the switching contacts thus eliminating the requirement for internal wiring and in turn removing a potential circuit failure mechanism.

M4 screw terminals allow 2x crimp lug connections per point. Space efficient design allows 28 contact points per terminal block.

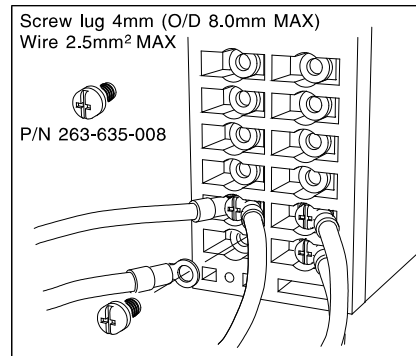

Figure 6: Rear terminal wiring configuration

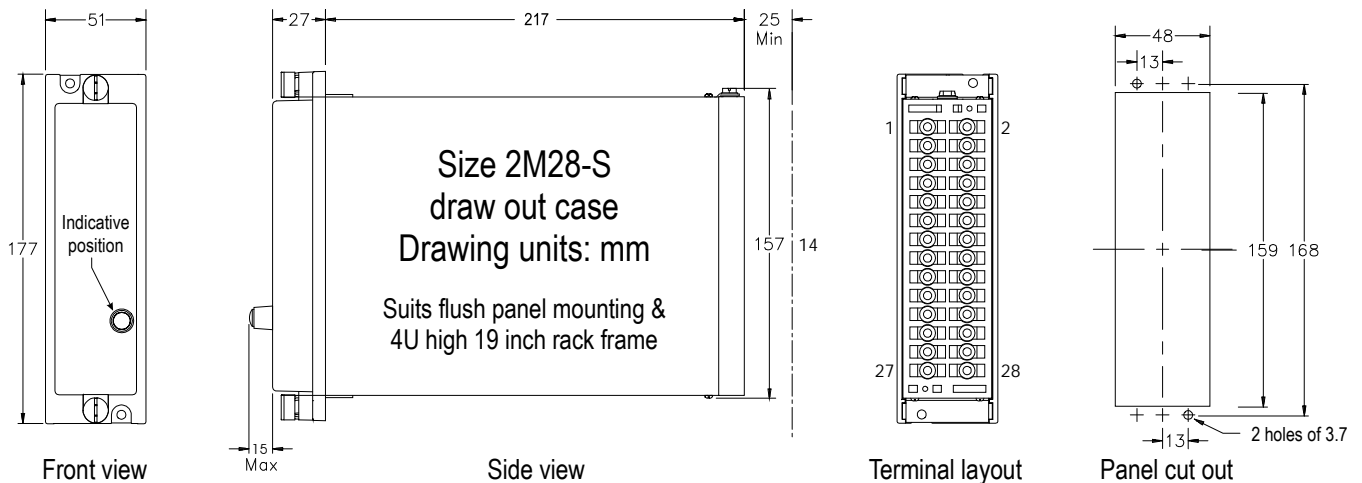

Figure 7: PR5 case details

Terminal Wiring

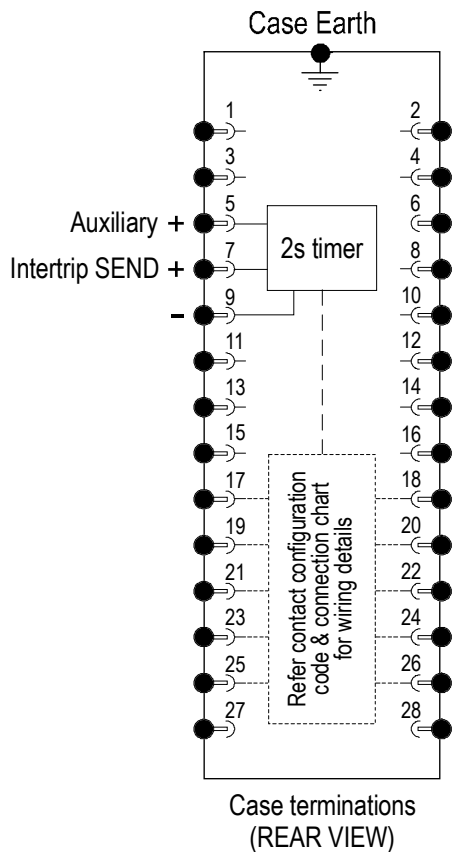

Figure 8: PR5-S Rear terminal layout

STANDARD WIRING CONFIGURATION

The case termination diagram in figure 8 depicts the rear screw terminals and position of the operate and reset coils. Note the connection polarity for correct DC operation of the auxiliary supply and intertrip SEND initiate.

Auxiliary: Terminals 5+ 9-

Intertrip SEND: Terminals 7

The contact function between each pairs of terminals is determined by the order code selected.

M Normally open Make (M) contact
This contact closes when the relay operate coil is energized.

B Normally closed Break (B) contact
This contact opens when the relay operate coil is energized.

Table 1 provides the terminal wiring assignment for each of the contact configurations available with the PR5-S relay version.

This wiring table is also printed on the side panel of the draw out module for easy reference in the field.

Contact Configuration	PR5 Case Terminal Number Pairs				
	17-18	19-20	21-22	23-24	25-26
P 4M+1B	M	M	M	M	B
Q 3M+2B	B	M	M	M	B
R 2M+3B	B	M	M	B	B
S 1M+4B	B	B	M	B	B

Table 1: Contact configuration and connection chart for the five (5) contact PR5 version

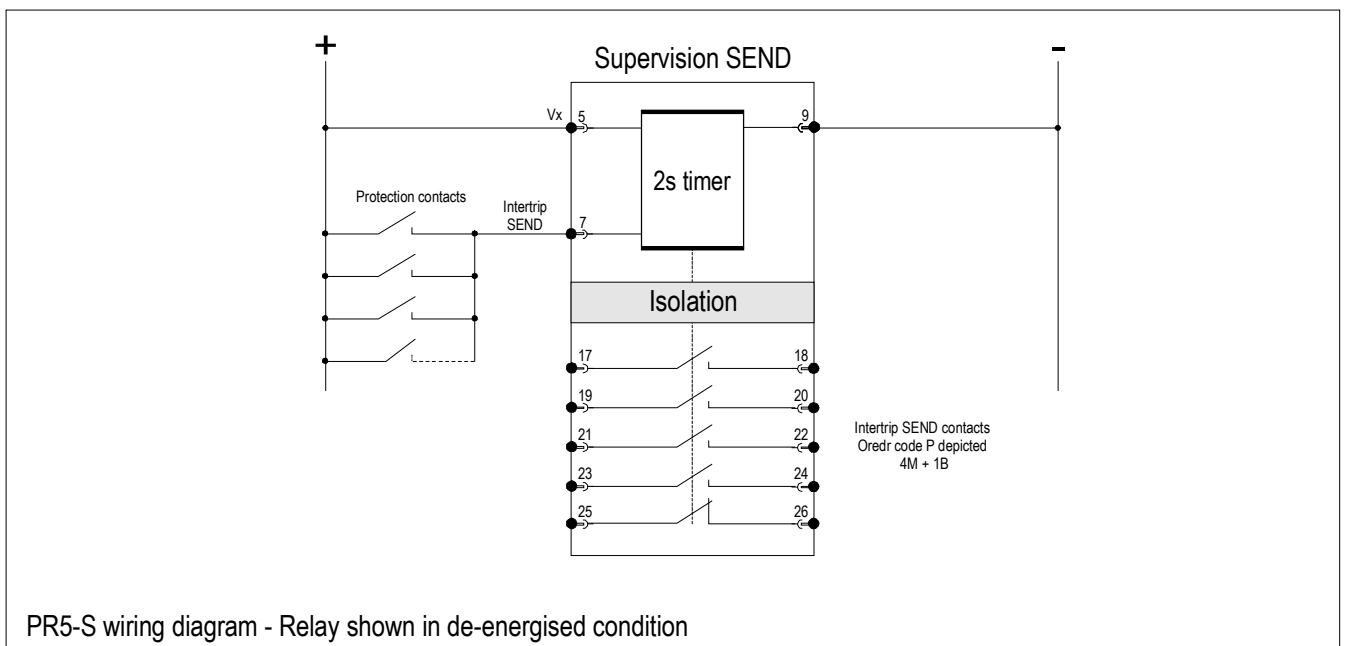
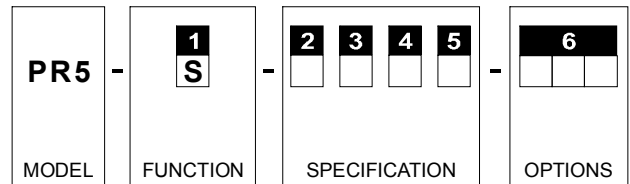

Figure 9: PR5-S application diagram

PR5 Ordering Codes

Generate the required ordering code as follows:
e.g. PR5-S-DP14-L



1 PR5 FUNCTION

S Pilot wire intertrip SEND relay

2 NOMINAL OPERATE VOLTAGE

B 32 V DC (30/32V DC systems)
 C 48 V DC
 D 110 V DC
 E 125 V DC
 F 220 V DC
 G 240 V DC
 H 250 V DC

3 CONTACT CONFIGURATION - Refer Table 1

P 4M + 1B Standard configuration
 Q 3M + 2B
 R 2M + 3B
 S 1M + 4B

4 CONTACT OPERATION

1 Self reset contacts

5 FLAG INDICATORS

1 Armature flag - Flag resets with contacts
 2 Hand reset flag - Flag resets with front panel button
 3 Both flags fitted - Flag order codes 1 and 2
 4 No flags required
 5 Reverse acting armature flag
 6 Reverse acting hand reset flag

6 OPTIONS (Specify all options required)

- None
 G Gold plated contacts
 L Coil operation LED
 T Custom front panel text – complete the 2 x 12 characters text box below and submit with order

The element order code is used as the default front panel text

Australian Content

Unless otherwise stated the product(s) quoted are manufactured by RMS at our production facility in Melbourne Australia. Approximately 60% of our sales volume is derived from equipment manufactured in house with a local content close to 80%. Imported components such as semi-conductors are sourced from local suppliers & preference is given for reasonable stock holding to support our build requirements.

Quality Assurance

RMS holds NCSI (NATA Certification Services International), registration number 6869 for the certification of a quality assurance system to AS/NZS ISO9001-2008. Quality plans for all products involve 100% inspection and testing carried out before despatch. Further details on specific test plans, quality policy & procedures may be found in section A4 of the RMS product catalogue.

Product Packaging

Protection relays are supplied in secure individual packing cardboard boxes with moulded styrene inserts suitable for recycling. Each product & packing box is labeled with the product part number, customer name & order details.

Design References

The products & components produced by RMS are based on many years of field experience since Relays Pty Ltd was formed in 1955. A large population of equipment is in service throughout Australia, New Zealand, South Africa & South East Asia attesting to this fact. Specific product & customer reference sites may be provided on application.

Product Warranty

All utility grade protection & auxiliary relay products, unless otherwise stated, are warranted for a period of 24 months from shipment for materials & labour on a return to factory basis. Repair of products damaged through poor application or circumstances outside the product ratings will be carried out at the customer's expense.

Standard Conditions of Sale

Unless otherwise agreed RMS Standard Terms & Conditions (QF 907) shall apply to all sales. These are available on request or from our web site.



Relay Monitoring Systems Pty Ltd

6 Anzed Court, Mulgrave, Victoria 3170, AUSTRALIA

Tel: +61 3 8544 1200 Fax: +61 3 8544 1201 Email: rms@rmspl.com.au Web: www.rmspl.com.au