



Reyrolle
Protection
Devices

7PG21 Solkor Rf

Feeder Protection

Answers for energy

SIEMENS

Contents

Technical Manual Chapters

1. Description of Operation
2. Performance Specification
3. Applications Guide
4. Settings
5. Installation
6. Commissioning
7. Diagrams

The copyright and other intellectual property rights in this document, and in any model or article produced from it (and including any registered or unregistered design rights) are the property of Siemens Protection Devices Limited. No part of this document shall be reproduced or modified or stored in another form, in any data retrieval system, without the permission of Siemens Protection Devices Limited, nor shall any model or article be reproduced from this document unless Siemens Protection Devices Limited consent.

While the information and guidance given in this document is believed to be correct, no liability shall be accepted for any loss or damage caused by any error or omission, whether such error or omission is the result of negligence or any other cause. Any and all such liability is disclaimed.

7PG21 Solkor Rf

Feeder Protection

Document Release History

This document is issue 2010/02. The list of revisions up to and including this issue is:

Pre release

02/2010	Document reformat due to rebrand

Software Revision History

--	--	--

The copyright and other intellectual property rights in this document, and in any model or article produced from it (and including any registered or unregistered design rights) are the property of Siemens Protection Devices Limited. No part of this document shall be reproduced or modified or stored in another form, in any data retrieval system, without the permission of Siemens Protection Devices Limited, nor shall any model or article be reproduced from this document unless Siemens Protection Devices Limited consent.

While the information and guidance given in this document is believed to be correct, no liability shall be accepted for any loss or damage caused by any error or omission, whether such error or omission is the result of negligence or any other cause. Any and all such liability is disclaimed.

Contents

1	General	3
2	Description	4
3	Operation	6
4	Theory of Summation Transformer.....	13

List of Tables

Figure 1	Solkor Rf schematic.....	4
Figure 2	Solkor R schematic.....	4
Figure 3	Solkor Rf 15kV schematic	5
Figure 4	Through Fault, zero ohm pilots, Positive half cycle.	7
Figure 5	Through Fault, zero ohm pilots, Negative half cycle.....	7
Figure 6	Through Fault, 1000 ohm pilots, Positive half cycle.	8
Figure 7	Through Fault, 1000 ohm pilots, Positive half cycle.	8
Figure 8	Through fault Rf mode, positive half cycle.....	9
Figure 9	Through fault Rf mode, negative half cycle	9
Figure 10	Through fault Rf mode, positive half cycle.....	10
Figure 11	Through fault Rf mode, positive half cycle.....	10
Figure 12	Internal fault Rf mode, positive half cycle	11
Figure 13	Internal fault Rf mode, positive half cycle	11
Figure 14	Single End Fed fault Rf mode, positive half cycle.....	12
Figure 15	Single End Fed fault Rf mode, negative half cycle	12

1 General

Solkor R & Rf are well established Pilot Wire Current Differential Protection for use with privately owned 2 core pilots with relatively high core resistance.

Solkor R/Rf protection benefits from the following main features:

- High transient stability
- High speed operation
- Low phase and earth fault settings
- Little or no variation of settings with pilot length
- In zone bleed off of up to 20% of rated load
- Easy to install, commission and maintain
- 15kV pilot isolation option
- Easily reconnected as either Solkor Rf or Solkor R
- Pilot Supervision schemes available
- Remote end injection intertripping via pilot cores available

2 Description

The Solkor Rf protection system (excluding current transformers) is shown below. The alternative basic Solkor R protection circuit is also shown.

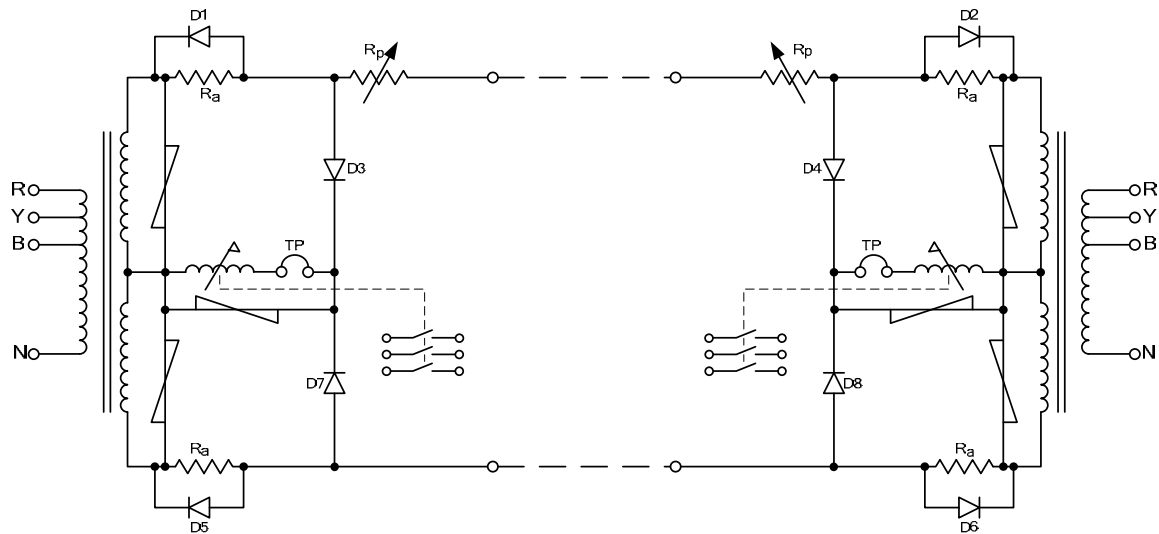

Figure 1 Solkor Rf schematic

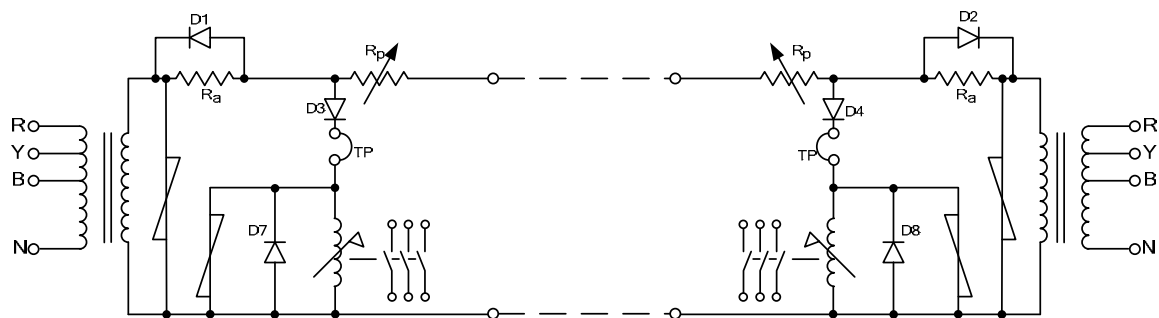

Figure 2 Solkor R schematic

Conversion of the Solkor Rf to Solkor R is arranged by wire links, internal to the relay.

The relay contains an 8-way internal terminal block. 4 wires marked 1-4 must be moved from 4 terminals marked 'Solkor Rf' to 4 adjacent terminals marked 'Solkor R'. Additionally a wire link must be fitted, externally to the relay on the rear terminal block to use the relay in Solkor R mode.

In addition to the basic components there are at each end, three non-linear resistors, a tapped 'pg' resistor and three diodes. The non-linear resistors are used to limit the voltage appearing across the pilots and the operating element. The purpose of the 'padding' resistors at each end is to bring the total pilot loop resistance up to a standard value. The protection is therefore always working under constant conditions and its performance is to a large extent of the resistance of the pilot cable. The 'padding' resistors comprise five series connected sections, each section having a short circuiting link. The values of the resistance on the sections are 35 ohms, 65 ohms, 130 ohms, 260 ohms and 500ohms.

For Solkor R the value chosen should be as near as possible to $\frac{1}{2}(1000-R_p)$ ohms, where R_p is the pilot resistance. The 500 ohm resistor should therefore be fitted for the Solkor R and the link will always be fitted for this mode.

For Solkor Rf without isolating transformers the value chosen should be as near as possible to $\frac{1}{2}(2000-R_p)$ ohms.

For Solkor Rf with isolating transformers the value chosen should be as near as possible to

$$\frac{1}{2}(SV-R_p)/T \text{ ohms.}$$

where T = Isolating transformer tap.

& SV = Standard resistance value for tap on transformers,

$$1780\Omega \text{ for tap1, } 880\Omega \text{ for tap 0.5 \& } 440\Omega \text{ for tap 0.25}$$

The operating element is of the attracted armature type with three contacts, each pair being brought out to separate terminals. The inherent advantages of such a relay are robustness and simplicity and since the contacts are suitable for direct operation of a circuit breaker trip coil, no repeat relay is necessary.

A 5kV insulation level is provided between the secondary winding of the summation transformer and its primary winding. The core and the relay coil is also insulated at 5kV.

Since the only external connections to the relay are those to the current transformers, the pilots and the tripping and alarm circuits, the installation and commissioning of the equipment is extremely simple. To check the current in the operating element, a test point is provided.

The 15kV arrangement is for applications where the voltage across the pilot insulation due to induction or a rise in station earth potential are excessive and where, consequently, the normal 5kV insulation level is not considered adequate. The complete protection scheme is shown in figure below.

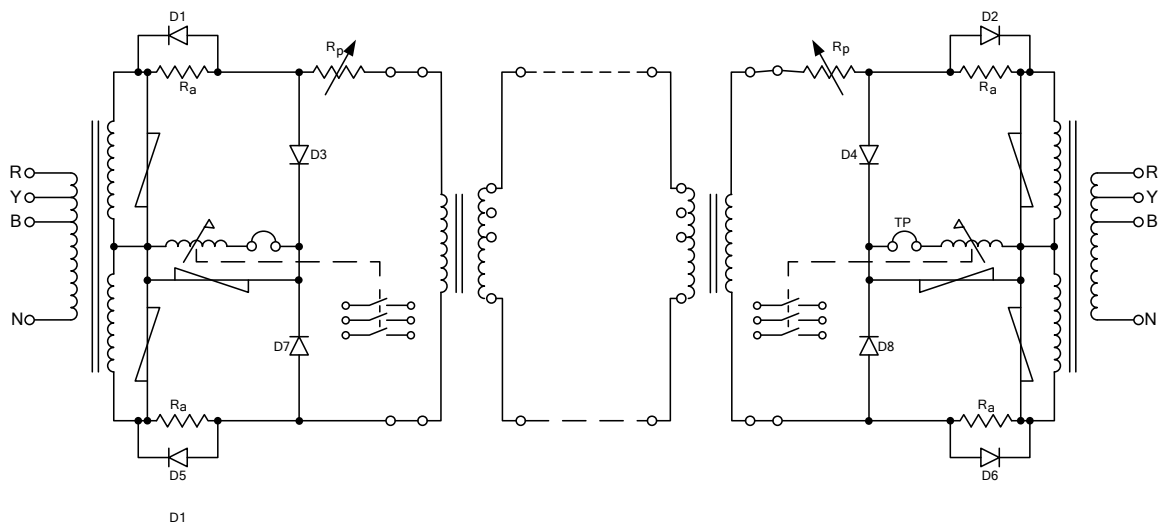

Figure 3 Solkor Rf 15kV schematic

The difference between this circuit and that shown previously is that the pilots are connected via interposing transformers which incorporate 15kV insulation barriers between windings to isolate the pilot circuit. The introduction of the isolating transformer does not modify the basic principle of operation of the protection but allows greater range of pilot coverage by the use of taps on the isolating transformer secondary windings.

3 Operation

Solkor R belongs to the circulating current class of differential protections which can be recognised by two main features. Firstly, the current-transformer secondaries are arranged to produce a current circulating around the pilot loop under external fault conditions. Secondly, the protective relay operating coils are connected in shunt with the pilots across points which have the same potential when the current circulates around the pilot loop. In this particular scheme equipotential relaying points during external fault conditions exist at one end during one half cycle of fault current, and at the other end during the next half cycle. During half cycles when the relay at either end is not at the electrical midpoint of the pilot system the voltage appearing across the relay is in the reverse direction to that required for operation.

At each end of the feeder the secondaries of the current transformers are connected to the primary of the summation transformer – see section 4 Theory of Summation Transformer. For various types of current distribution in the three current transformers, a single phase quantity appears in the summation transformer secondary winding and is applied to the pilot circuit. By this means a comparison between the currents at each end of a three phase line is effected over a single pair of pilot wires on an equivalent single phase basis. The tapings on the summation transformer primary have been selected to give an optimum balance between the demands of fault setting and stability.

The pilot is shown as a 'lumped' resistor R_p . The rest of the pilot loop is made up of four resistors R_a and four diodes D1, D2, D5 and D6. The operating elements, which are made unidirectional by diodes D3, D4, D7 and D8 are connected in shunt with the pilots.

During an external fault condition, an alternating current circulates around the pilot loop. Thus on successive half cycles one or other of the resistors R_a at the two ends of the pilot is short circuited by its associated diode D1 or D2. The total resistance in each leg of the pilot loop at any instant is therefore substantially constant and equal to $R_a + R_p$. The effective position of R_a however, alternates between ends, being dependent upon the direction of the current. The change in the effective position of R_a makes the voltage distribution between the pilot cores different for successive half-cycles of the pilot current.

In other words stability is achieved by current balance using the Solkor R principle of establishing the electrical centre point geographically within the end which has positive polarity so that the positively polarised measuring elements remain in the negative part of the circuit and are thus biased against operation.

Referring to the basic circuit of Solkor Rf as shown in Figure 1, the circulating current will flow from the summation transformer through the diode or the resistor depending on the polarity of the summation transformer output. Thus the circuit may be redrawn to suit the polarities of summation transformer output as shown in Figure 4 & Figure 5 below.



Figure 4 Through Fault, zero ohm pilots, Positive half cycle.

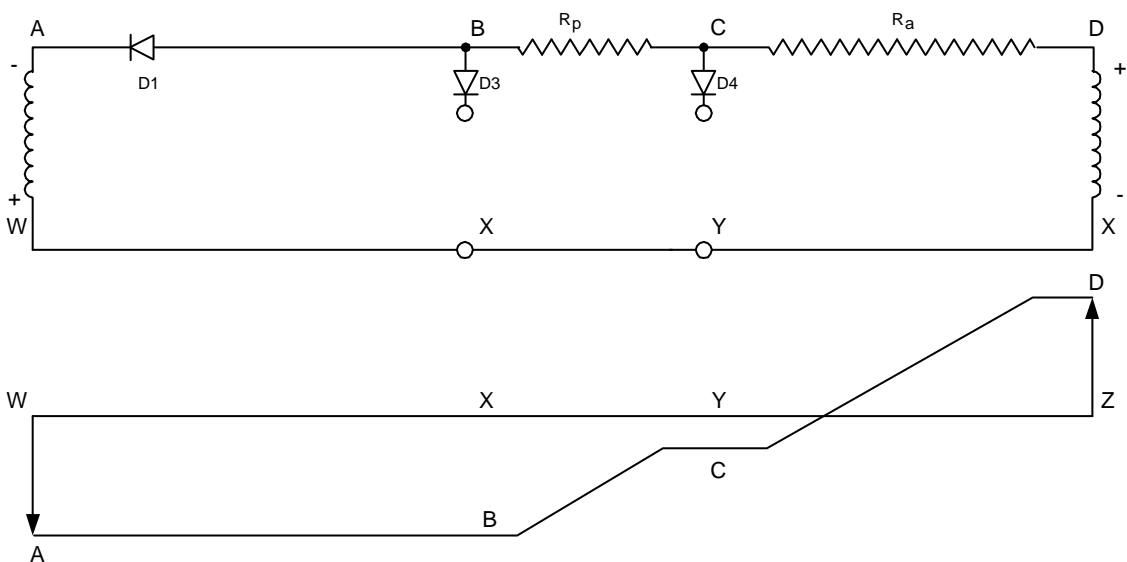

Figure 5 Through Fault, zero ohm pilots, Negative half cycle.

Figure 4 & Figure 5 above represents the operations of Solkor R protection with zero ohm pilots so that the loop resistance is represented entirely by the 500 ohm padding resistor in each relay and the 1000ohm sum in the pilot circuit is in one leg of the pilot circuit as shown, R_p .

Resistors R_a are of greater resistance than the pilot loop resistance R_p and this causes the point of zero potential to occur within the resistors R_a , as shown in Figure 5. The voltage across each relaying point (B-X and C-Y) throughout the cycle is now always negative. This voltage bias must be overcome before operation can take place; consequently the effect is to enhance the stability of the protection against through faults.

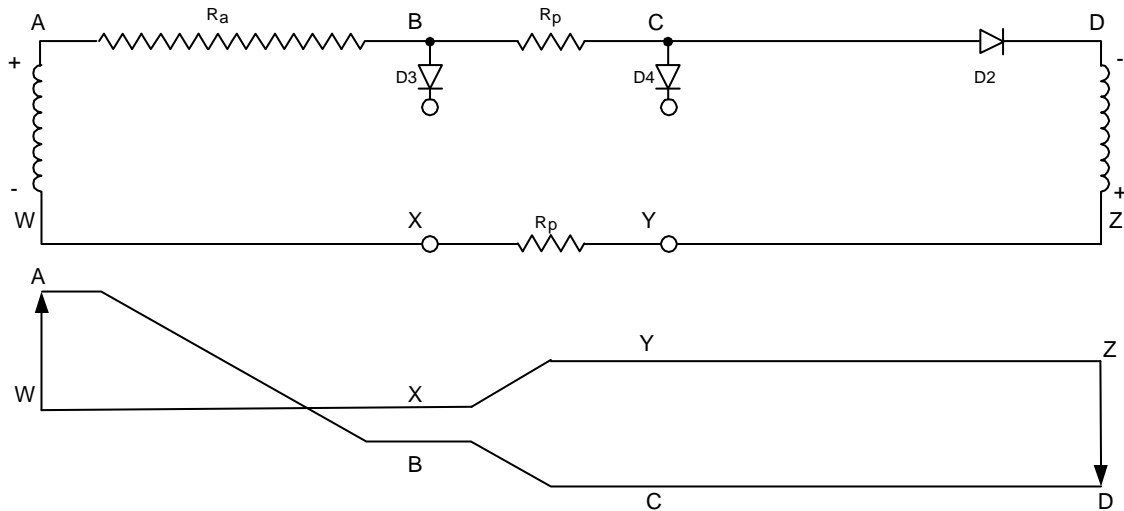

Figure 6 Through Fault, 1000 ohm pilots, Positive half cycle.

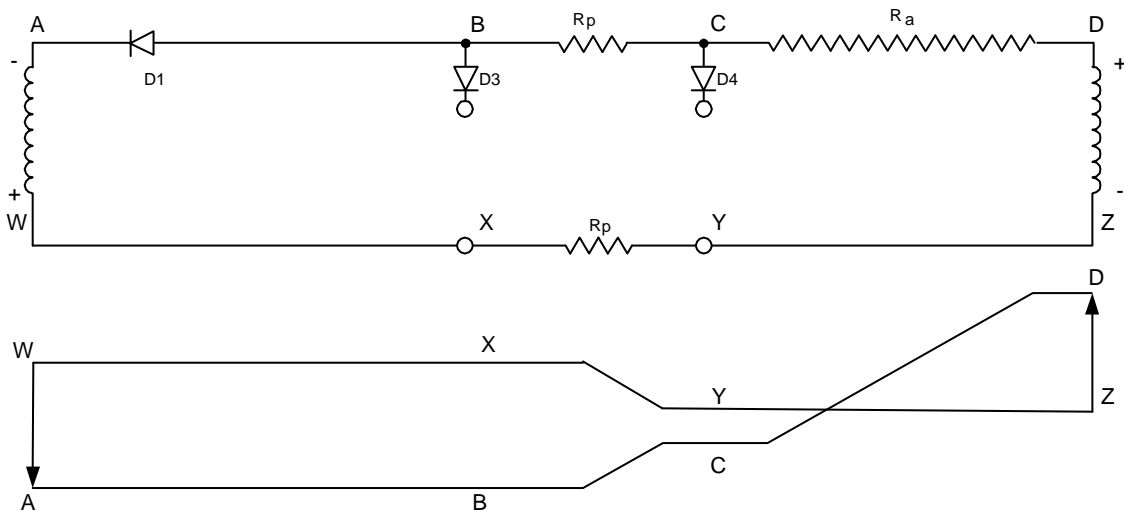

Figure 7 Through Fault, 1000 ohm pilots, Positive half cycle.

At the other limiting condition the pilot resistance is a 1000 ohms loop and the circuit will be as shown in Figure 6 & Figure 7. with 500 ohms in each leg of the pilot circuit and zero padding resistors. As shown in Figure 6 & Figure 7 the resultant voltage distribution of this maximum pilot arrangement gives identical voltages across the relay points B-X and C-Y.

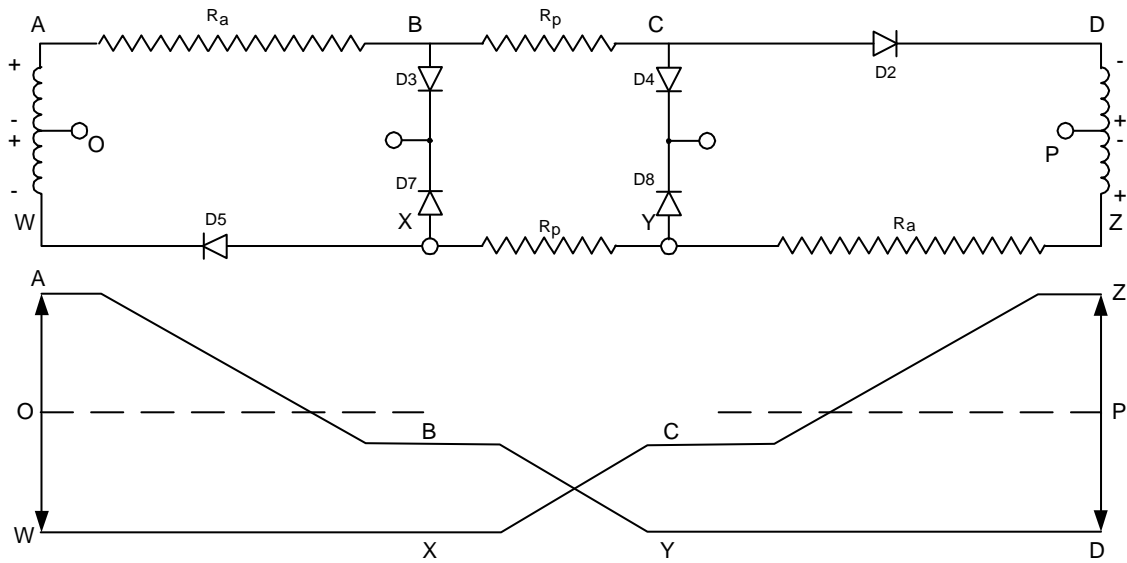

Figure 8 Through fault Rf mode, positive half cycle

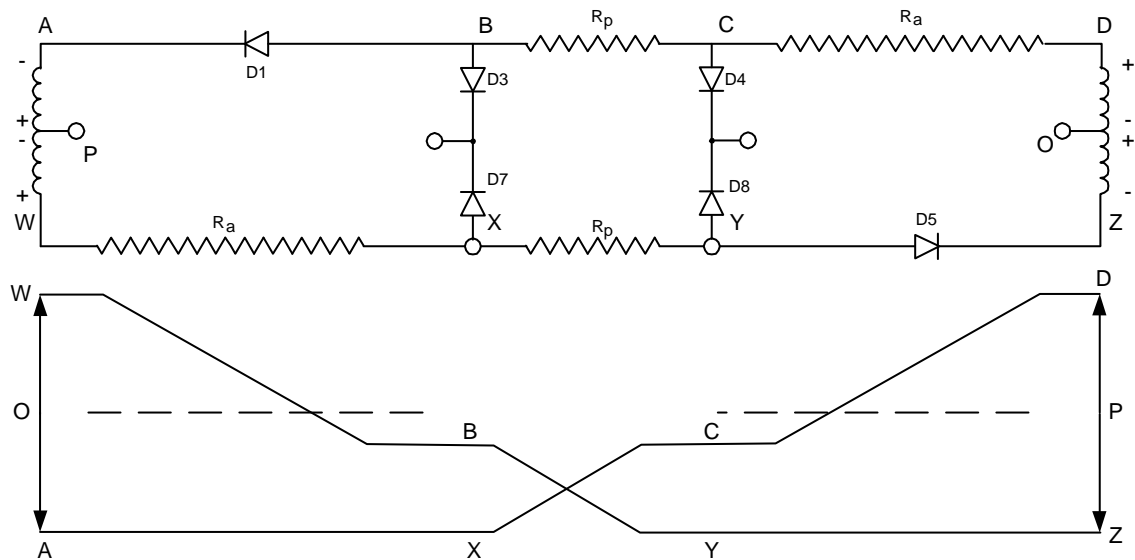

Figure 9 Through fault Rf mode, negative half cycle

Considering now the equivalent Solkor Rf circuit with 1000 ohms in each leg of the pilots as shown in Figure 8. the voltage distribution shows that the bias voltage across the polarising diodes (D3, D4, D7 and D8) with this arrangement are effectively identical with the minimum values obtained in the Solkor R arrangement. In other words, the balance of the full wave comparison gives the same value of bias for each polarity of half-cycle.

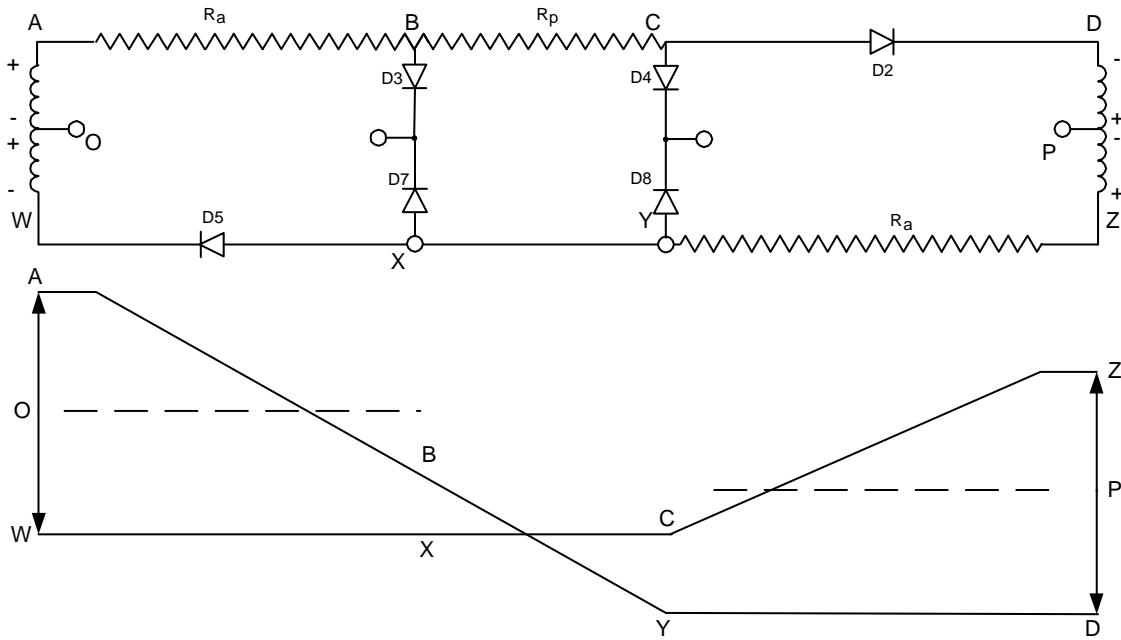

Figure 10 Through fault Rf mode, positive half cycle

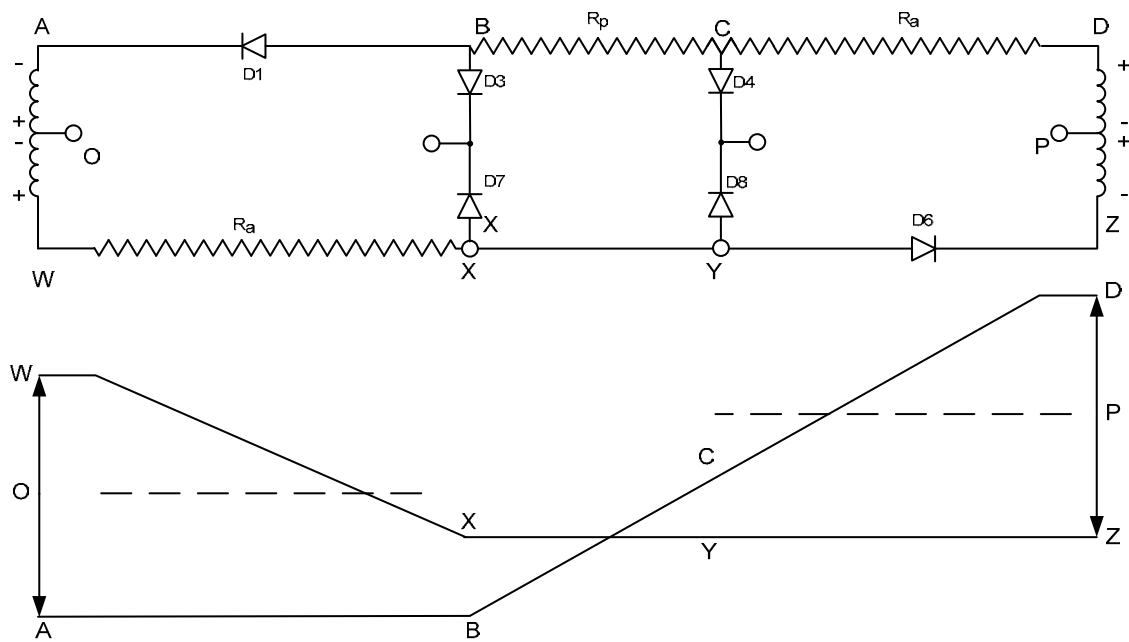

Figure 11 Through fault Rf mode, positive half cycle

If the condition of zero pilots is then considered for Solkor Rf (i.e. with 1000 ohms padding in each relay), the circuit and voltage distribution are as shown in Figure 10 & Figure 11. This shows that the same bias voltages are as obtained in Figure 8 & Figure 9.

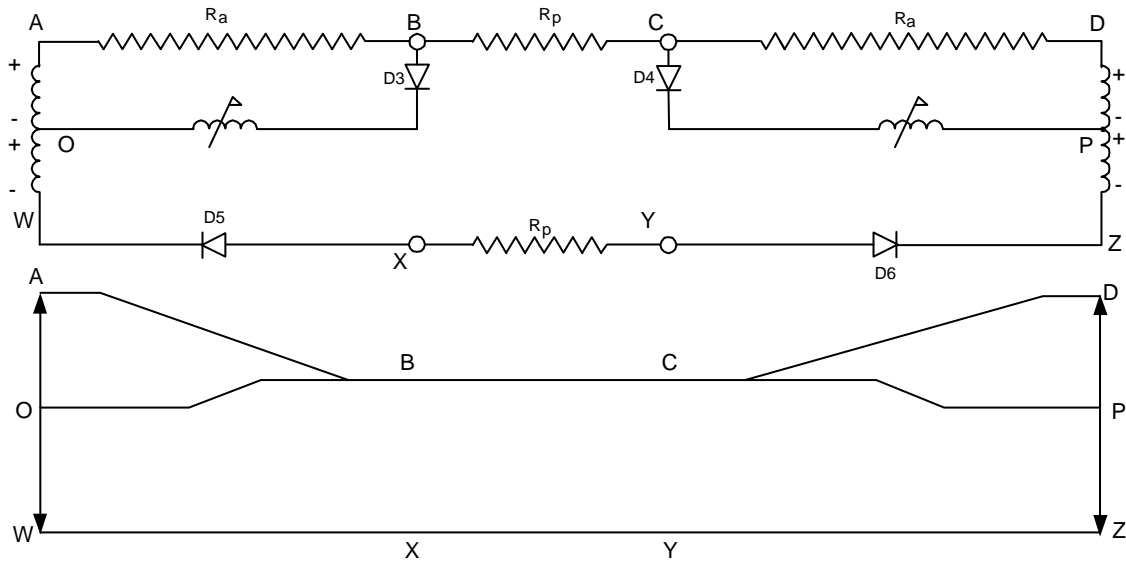

Figure 12 Internal fault Rf mode, positive half cycle

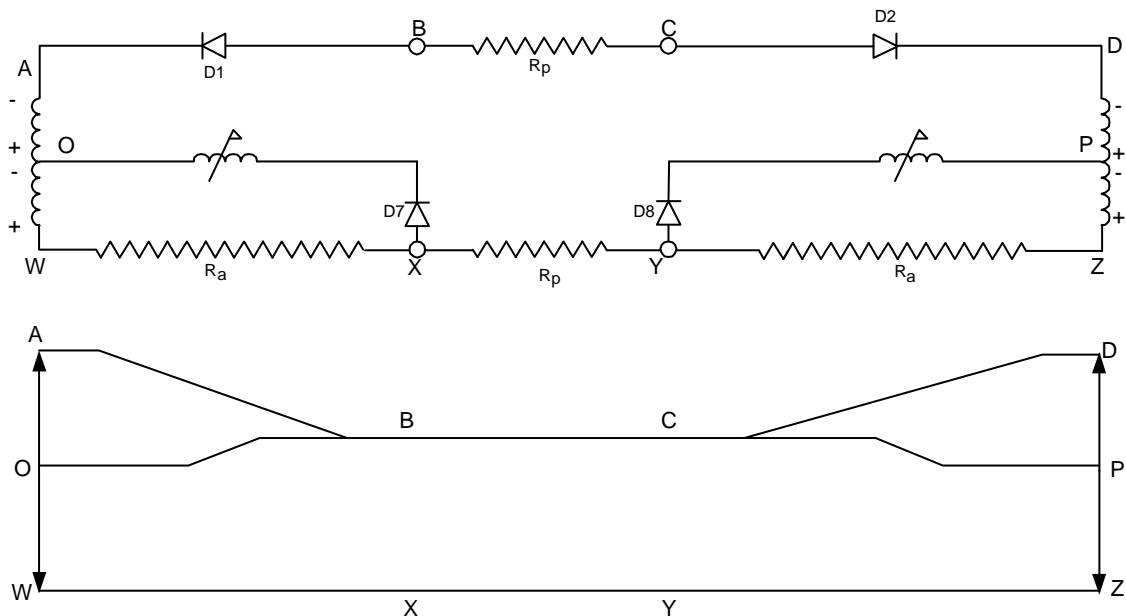

Figure 13 Internal fault Rf mode, positive half cycle

The application of pilot wire protection is generally in interconnected power systems so that it is reasonable to consider double end fed faults. For simplicity in explaining the basic principles, it may be assumed that the infeeds at both ends have the same magnitude and relative phase angle. The Solkor Rf circuit is then effectively as shown in Figure 12 & Figure 13 because the diodes in series with the pilots on the positive leg of the circuit will be out of circuit and the measuring element polarising diodes on this leg will be conducting. The voltage distribution for this arrangement shows how, with the assumed balanced infeeds, no current flows in the pilots and each measuring element is energised via the resistor R_a .

The single end fed internal fault operates both measuring elements from the one end so that the setting level is twice that of the double end fed arrangement. However, both ends operate at this level (which is the normal setting claim) so that the intertripping is not required for internal faults even those which may be fed from one end or have low infeed at one end.

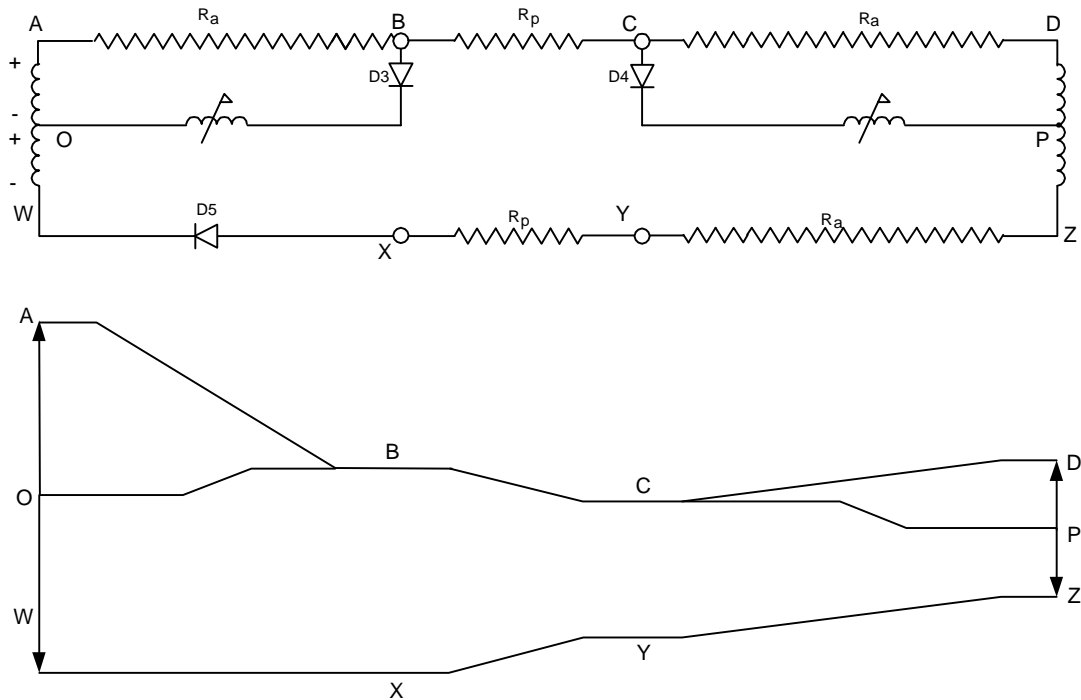

Figure 14 Single End Fed fault Rf mode, positive half cycle

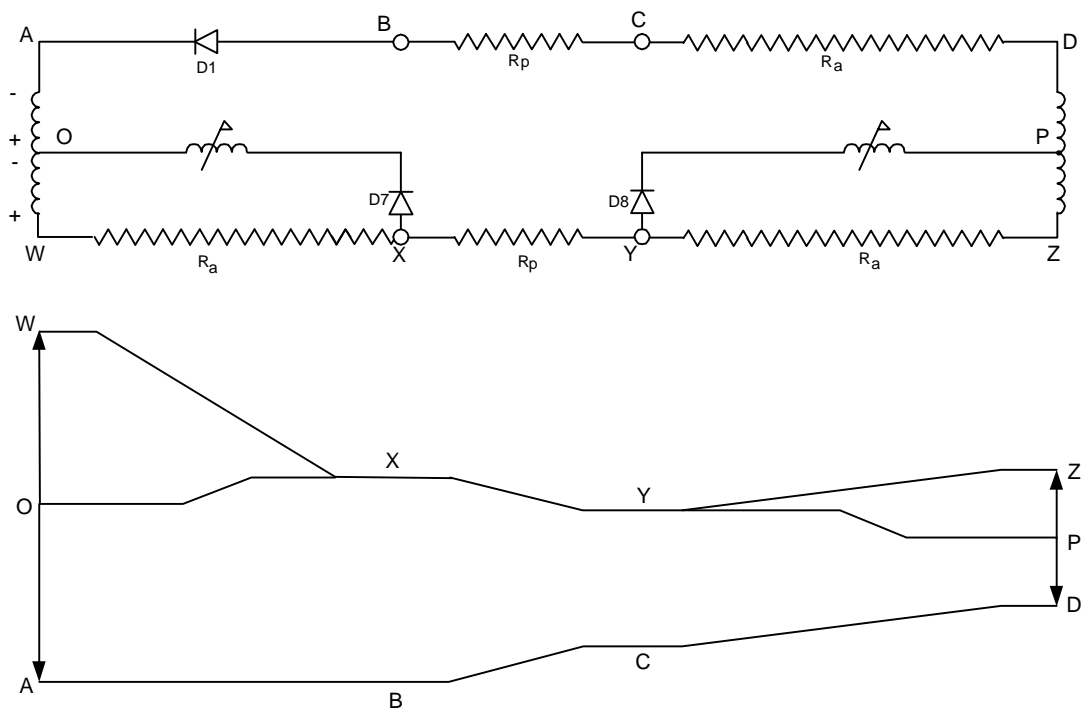
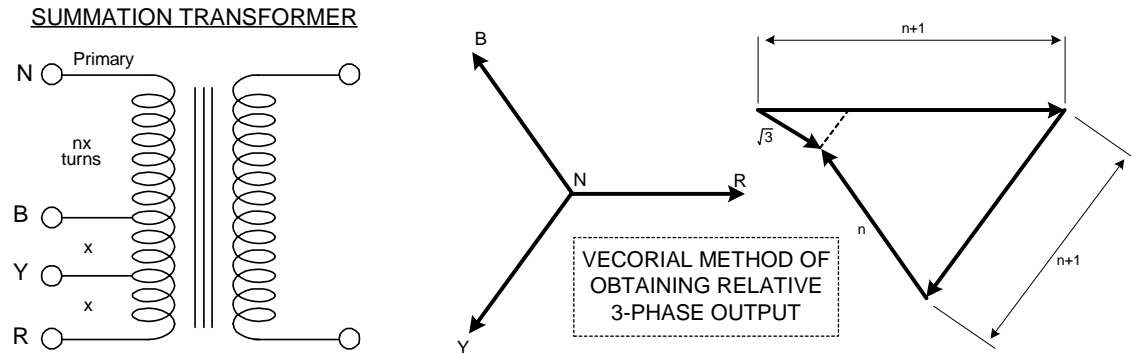

Figure 15 Single End Fed fault Rf mode, negative half cycle

The single end fed internal fault conditions configure the circuit in a similar way to the double end fed internal fault but only one summation transformer has any output. Thus the other summation transformer acts only as an equalising transformer, re-circulating current through the measuring element as indicated in Figure 14 & Figure 15. The voltage distribution shows diagrammatically how, in each half cycle, the measuring elements are energised via R_a at the energised end and the action of the remote end summation transformer re-circulating current via the polarising diodes D4 on one half-cycle and D8 on the other half-cycle.

4 Theory of Summation Transformer

The main purpose of the summation transformer is to enable either balanced or unbalanced three phase currents to be re-produced as a single phase quantity. This makes it possible in a feeder protection to compare the various fault currents on a single phase basis over only two pilot cores. As this device is essentially a transformer it can also be used to reduce the burden imposed by the pilot circuit on the current transformers by changing the impedance levels. In addition, it provides isolation between the current transformers and the pilot circuit and makes it possible to have the current transformers earthed and the pilots unearthed.



Fault Type	Effective Primary Ampere-turns	Relative Output
R-E	$I(nx + x + x) = Ix. (n+2)$	$n+2$
Y-E	$I(nx + x) = Ix. (n+1)$	$n+1$
B-E	$I(nx) = Ix. (n)$	n
R-Y	$I(x) = Ix. (1)$	1
Y-B	$I(x) = Ix. (1)$	1
B-R	$I(2x) = Ix. (2)$	2
3P	$I(\sqrt{3}x) = Ix. (\sqrt{3})$	$\sqrt{3}$

7PG21 Solkor Rf

Feeder Protection

Document Release History

This document is issue 02/2010. The list of revisions up to and including this issue is:

Pre release

02/2010	Document reformat due to rebrand

Software Revision History

--	--	--

The copyright and other intellectual property rights in this document, and in any model or article produced from it (and including any registered or unregistered design rights) are the property of Siemens Protection Devices Limited. No part of this document shall be reproduced or modified or stored in another form, in any data retrieval system, without the permission of Siemens Protection Devices Limited, nor shall any model or article be reproduced from this document unless Siemens Protection Devices Limited consent.

While the information and guidance given in this document is believed to be correct, no liability shall be accepted for any loss or damage caused by any error or omission, whether such error or omission is the result of negligence or any other cause. Any and all such liability is disclaimed.

Contents

1	General.....	3
2	Characteristic Energising Quantity.....	3
3	Application Limits	3
4	Performance.....	3
4.1	Solkor R/Rf Relay	3
4.2	Pilot Supervision Equipment.....	4
4.3	Injection Intertripping	5
5	Environment	5
5.1	Temperature	5
5.2	Humidity.....	5
5.3	IP Ratings	5
6	Mechanical Durability	5

1 General

2 Characteristic Energising Quantity

Rated Current (In)	0.5A 1A 2A 5A 6.67A
--------------------	---------------------------------

Auxiliary DC Supply	Not required for Solkor R/Rf, required for Pilot Supervision, intertripping and guard only.
---------------------	---

Rated Frequency (f _N)	Operating Range
50 Hz	47Hz to 52Hz
60Hz	57Hz to 62Hz

3 Application Limits

Number of Pilot cores required 2

Pilot Requirements

	R Mode	Rf Mode	Rf mode with 15kv Transf.		
			Tap 1	Tap 0.5	Tap 0.25
Max. Loop Resistance	1000 Ω	2000 Ω	1780 Ω	880 Ω	440 Ω
Max. Inter core Capacitance	2.5μF	0.8 μF	1 μF	2 μF	4 μF

Pilot Current and Voltage

	R Mode	Rf Mode	Rf mode with 15kv Transf.		
			Tap 1	Tap 0.5	Tap 0.25
Peak Voltage applied to pilots under fault conditions	300v	450v	450v	330v	225v
Maximum current carried by pilots under fault conditions	200mA	250mA	250mA	380mA	500mA

Maximum Primary Line Capacitive Charging Current.

Solidly Earthed System, 1/3 times the most sensitive earth fault setting

Resistance Earthed System, 1/9 times the most sensitive earth fault setting

4 Performance

4.1 Solkor R/Rf Relay

Insulation

Between pilot circuit and all other independent circuits and earth	5kV rms
Between all external terminal and earth	2kV rms
Between terminals of independent circuits	2kV rms
Across normally open contacts	1kV rms
Isolation Transformer Between pilot circuit terminals and all other terminals and earth	15kV rms

Maximum through fault condition for stability

50x rated current

Thermal Withstand (AC current)	Multiple of rated current
Continuous	2x
20 minutes	2.8x
10 minutes	3.5x
5 minutes	4.7x
3 minutes	6.0x
2 minutes	7.3x
3 seconds	60x
1 second	100x limited to 400A

Operating Time	R Mode	5kV Rf Mode	15kV Rf Mode
3x fault setting	60ms		
5x fault setting		45ms	40ms
10x fault setting	45ms		

Indication	Hand Reset Flag
Contact Arrangement	3 N/O
Contact Rating	Make and carry for 0.2s a burden of 6600VA with a maximum of 30A

	R Mode	Rf Mode
Maximum output of CT required to operate relay	1.2VA	3VA

4.2 Pilot Supervision Equipment

Auxiliary Supply	
Send End	110/220/240V ac 50/60Hz
Receive End	30V dc 50V dc 125V dc 240V dc

Burdens

AC Supervision Supply	10VA approx.
AC supply fail relay	3 to 5VA
Receive Repeat Relay	1W

Contact Arrangements

Pilot Supervision Relay(B75)	1NO self reset
Repeat relay B74	2NO & 2NC
Supervision supply fail relay	2NO & 2NC

Contact Ratings

Type B22, B74 and B75

Make & Carry Continuously	1500VA ac or 1500W dc within limits of 660V and 3A. Make and carry 8A for 3 secs or 16A for 1 second.
Break	300VA ac or 75W dc (inductive L/R -0.04) within limits of 250V and 5A

Indication	Flag indicators shown on de-energisation
------------	--

Supervision supply fail relay (B22)	Hand Reset Flag
Receive Repeat Relay	Self Rest Flag

Timing

B74 Repeat Element

Delay on drop off 400ms+-10%

4.3 Injection Intertripping

Rating Vx, 110-125V dc

Burden 1A at 125V dc full output

400mA with economy resistor

5 Environment

5.1 Temperature

IEC 60068-2-1/2

Type	Level
Operating range	-10 °C to +55 °C
Storage range	-25 °C to +70 °C

5.2 Humidity

IEC 60068-2-3

Type	Level
Operational test	56 days at 40 °C and 95 % relative humidity

5.3 IP Ratings

Type	Level
Installed with cover on	IP 51
Installed with cover removed	IP 30

6 Mechanical Durability

Vibration, relays comply with BS142 section 2.1 Category S2.

Shock, relays withstand 20G shock or impact on the panel without operating

Operation/mechanical life, relays will withstand in excess of 10,000 operations.

7PG21 Solkor Rf

Feeder Protection

Document Release History

This document is issue 02/2010. The list of revisions up to and including this issue is:

Pre release

02/2010	Document reformat due to rebrand

Software Revision History

--	--	--

The copyright and other intellectual property rights in this document, and in any model or article produced from it (and including any registered or unregistered design rights) are the property of Siemens Protection Devices Limited. No part of this document shall be reproduced or modified or stored in another form, in any data retrieval system, without the permission of Siemens Protection Devices Limited, nor shall any model or article be reproduced from this document unless Siemens Protection Devices Limited consent.

While the information and guidance given in this document is believed to be correct, no liability shall be accepted for any loss or damage caused by any error or omission, whether such error or omission is the result of negligence or any other cause. Any and all such liability is disclaimed.

Contents

1	General	3
2	Information Required when ordering	4
3	Equipment Options.....	5
3.1	Solkor Plain Protection Schemes.....	5
3.2	Pilot Supervision	5
3.2.1	5kV Schemes	5
3.2.2	15kV Schemes.....	5
3.3	Injection Intertripping 5kV or 15kV	5
3.3.1	R mode	5
3.3.2	Rf mode	5
3.4	Overcurrent Guard Relay.....	6
4	5/15Kv Isolation Voltage.....	10
5	Pilot Cables	10
6	Pilot Supervision.....	11
7	Overcurrent Guard Relays	11
8	Injection Intertripping	11
9	Capacitive Charging Currents	12
10	N/N1 Setting.....	12
11	In-Zone Tapped Load.....	12
12	Current Transformer Requirements.....	13

1 General

Solkor R & Solkor Rf are well established pilot wire feeder differential protections operating on the current balance principle. It is suitable for application on privately owned 2 core pilots with loop resistance up to 2000ohms to protect 2 ended feeder circuits up to 20km in length. Two identical relays are used as a pair with one relay connected to current transformers at each end of the feeder respectively.

Additional external Pilot Supervision equipment can be supplied to detect pilot cable open circuit which can lead to protection operation. Solkor relay trip contacts can be connected in series with those of an Overcurrent Guard relay to avoid operation for damaged pilots during normal load levels. Additional Intertripping equipment can also be supplied which utilises the pilot connection to initiate a protection operation at the remote end.

The Solkor R/Rf relay has an insulation level of 5kV between pilot connections and the local ground to withstand voltages induced on the pilot cable due to coupling with the fault current flowing in a parallel path and to withstand differential ground voltages caused by the flow of fault current. This is generally adequate for distribution feeders but for higher voltage systems where feeders may be longer and fault levels higher, an additional external isolation transformer is available for use with the relay in Rf mode to increase the voltage withstand to 15kV. One transformer should be fitted at each end of the pilot connection.

The R/Rf relay is primarily intended for use in the Rf mode which has the advantage of increased operating speed but can be simply changed to R mode for compatibility with pre-installed remote end relays which are older 5kv Solkor R type relays. The Solkor R/Rf relay is not compatible with the older 15kv Solkor R.

2 Information Required when ordering

Solkor Protection relay

- CT secondary Current Rating
- Case Styles
- Insulation level (5/15kV)
- Set as R or Rf mode

Pilot Supervision

- Case Styles
- System Frequency (50/60Hz)
- Send or Receive End
- Insulation level (5/15kV)
- Auxiliary DC supply

Guard Relays

- CT secondary Current Rating
- Case Styles
- System Frequency (50/60Hz)
- Not compatible with Intertripping
- Auxiliary DC supply (for numeric types)

Intertripping

- Not compatible with Guard Relays
- 1 way or 2 way intertripping
- Auxiliary DC supply
- R or Rf mode
- Insulation level (5/15kV)

3 Equipment Options

The following equipment lists provide an overview of the equipment normally required, highlighting differences for the various scheme options. These lists should be used in conjunction with the diagrams that follow.

3.1 Solkor Plain Protection Schemes

Solkor R/Rf relay (5kV), 1 per feeder end

15kV isolation transformer, 1 per feeder end if required

3.2 Pilot Supervision

3.2.1 5kV Schemes

3.2.1.1 Send End

Pilot Supervision Send End relay (transformer+rectifier), 1 per circuit
B22 AC Supply Supervision relay, 1 per circuit

3.2.1.2 Receive End

Pilot Supervision Receive End relay (B74 & B75), 1 per circuit

Note: Although the 5kV scheme utilises a combined B75/B74 unit, the additional isolation requirements at 15kV necessitate that separate units must be used.

3.2.2 15kV Schemes

3.2.2.1 Send End

15kV Pilot Supervision Send End relay (transformer+rectifier), 1 per circuit
B22 AC Supply Supervision relay, 1 per circuit. 5kV insulation as this is not connected to the pilots.

3.2.2.2 Receive End

15kV B75 relay, 1 per circuit

B74 relay, 1 per circuit

Note: Although the 5kV scheme utilises a combined B75/B74 unit, the additional isolation requirements at 15kV necessitate that separate units must be used.

3.3 Injection Intertripping 5kV or 15kV

(Equipment listed is for single ended intertripping for 2 ended intertripping, double quantities are required). Sustained intertripping will require one additional 300ohm 18W economy resistor per inverter.

3.3.1 R mode

Inverter for Solkor R
TEC relay

3.3.2 Rf mode

Inverter for Solkor Rf
TEC relay
B34 relay

3.4 Overcurrent Guard Relay

Argus 1 or B69, 3P Overcurrent, or 2P Overcurrent + 1P Earth Fault relay

Installation with Existing Solkor R relay.

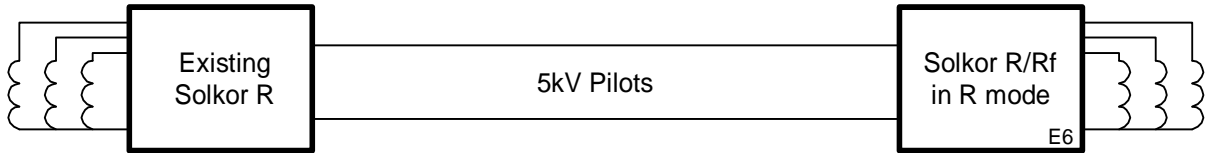

Standard 5kV Plain Solkor Rf.

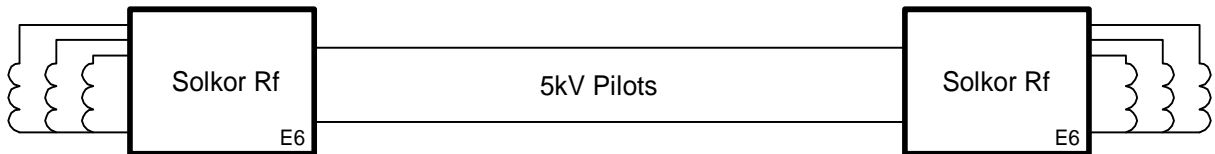

Standard 15kV Plain Solkor Rf.

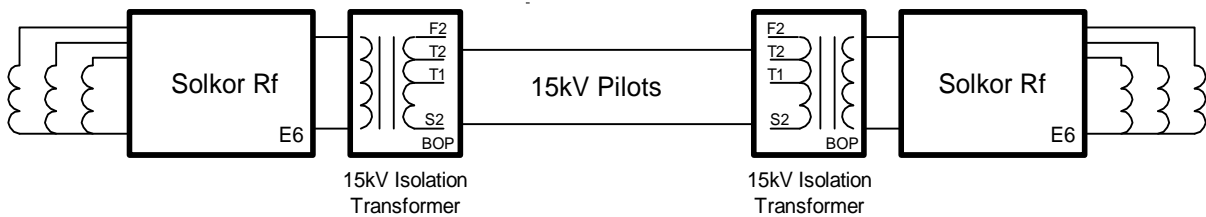

5kV Solkor Rf with Pilot Supervision.

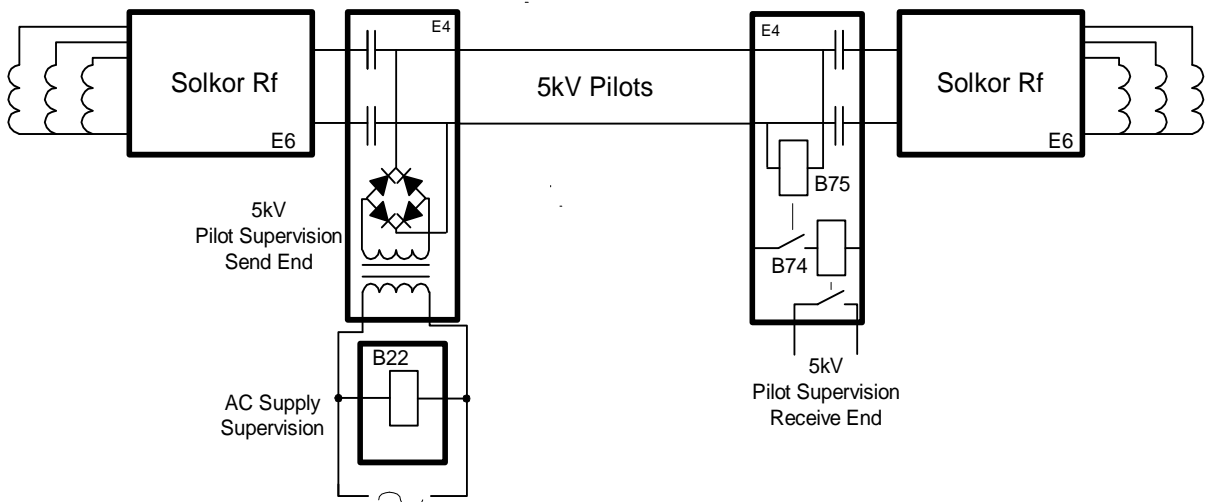

15kV Solkor Rf with Pilot Supervision.

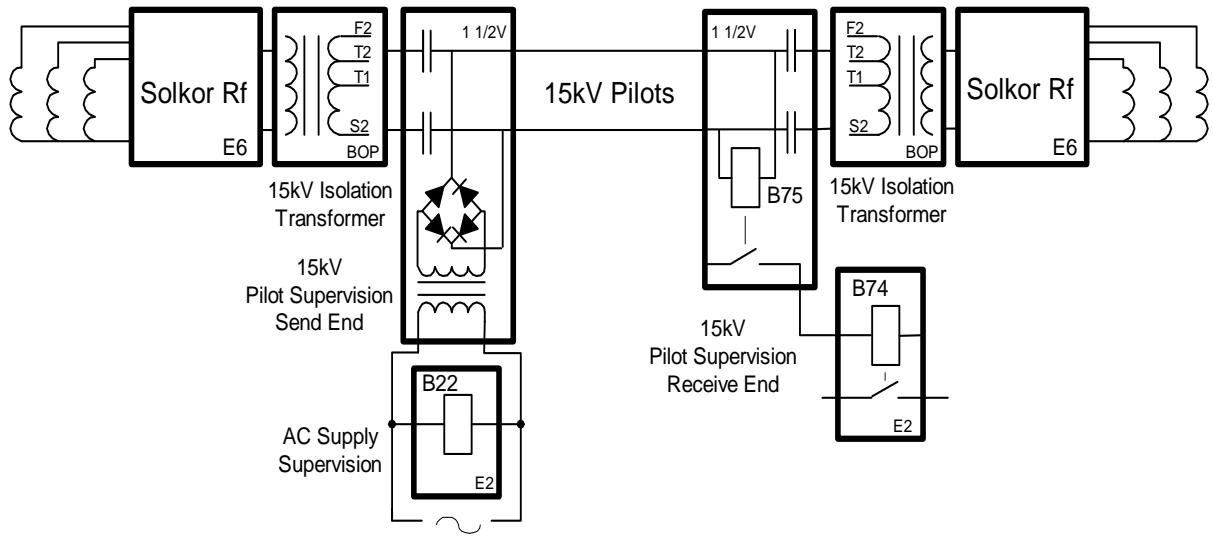

5kV Plain Solkor Rf with Overcurrent Guard.

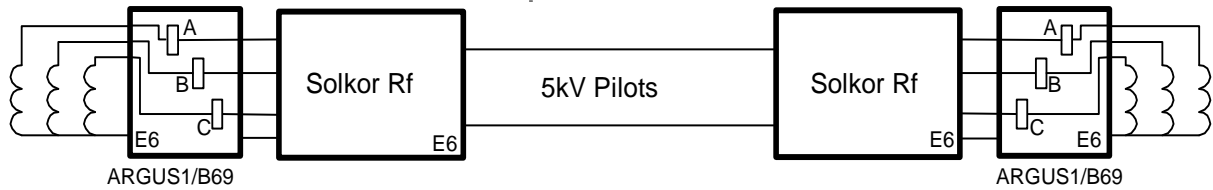

15kV Solkor Rf with Pilot Supervision and Overcurrent Guard.

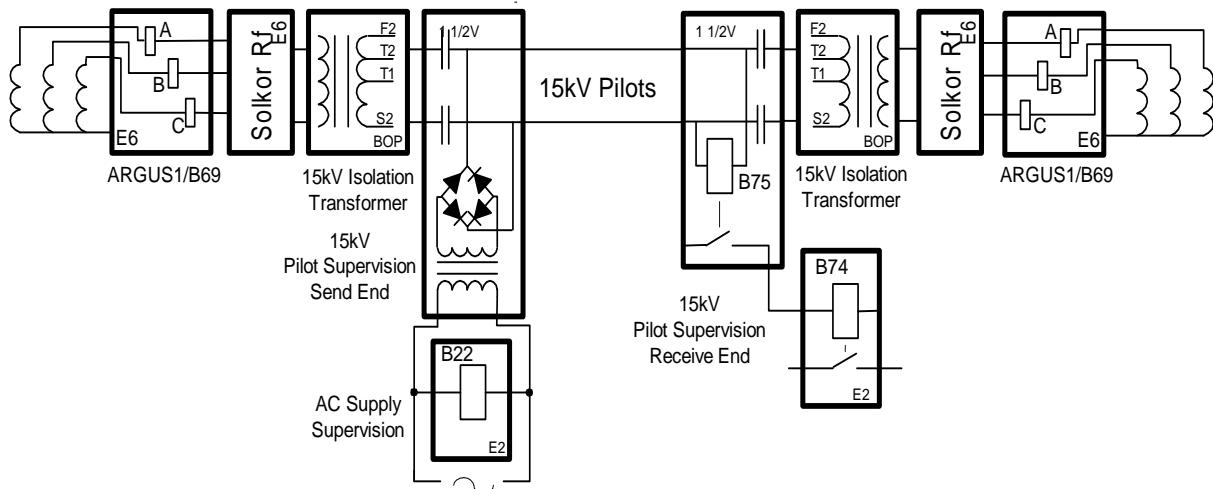

5kV Solkor R mode with One Way Injection Intertripping.

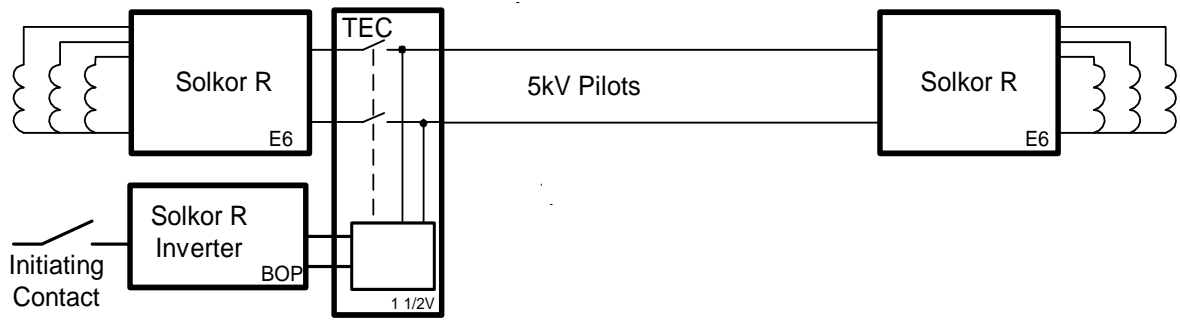

5kV Solkor Rf mode with One Way Injection Intertripping.

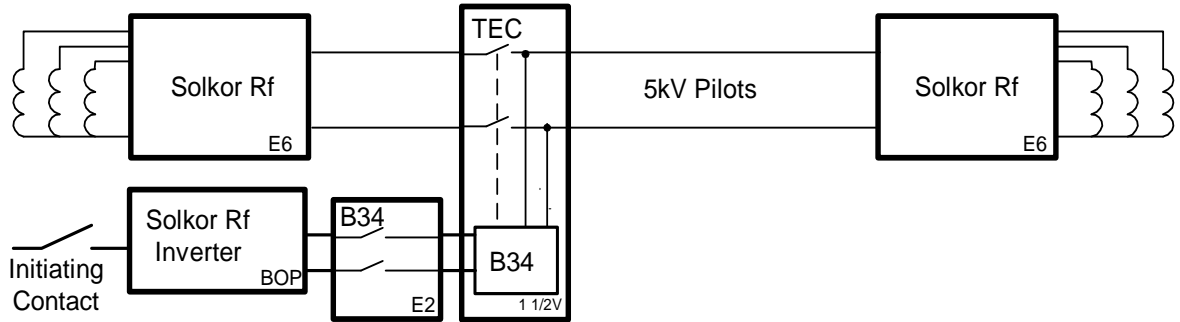

15kV Solkor Rf with Pilot Supervision and 2 Way Injection Intertripping.

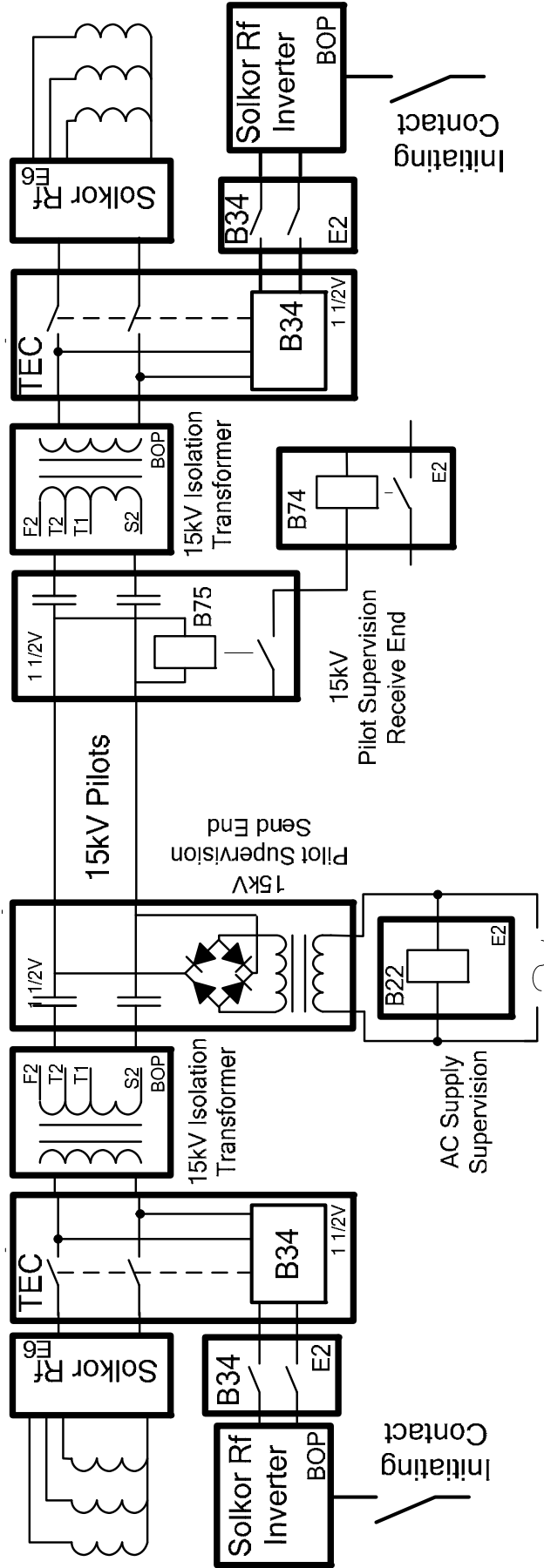

4 5/15Kv Isolation Voltage

Any electrical current which flows in a path parallel to the pilot cable will cause a voltage to be induced along the pilot cable. This voltage can become significant for large values of current, long lengths of parallel path and higher mutual coupling factors caused by poor screening or close proximity of current paths. This voltage can lead to flashover inside of the relay case from the circuits connected to the pilots to the relay case and local ground. The problem can be worsened by ground voltage shift between the two substations at the feeder ends due to earth fault current. Earth shift voltage is often ignored in cable power systems because of the high percentage of the earth fault current which returns through the cable sheath and armouring, however with overhead line systems the earth shift voltage can be as significant as the induced longitudinal voltage.

The Solkor R/Rf relay will withstand 5kV rms voltage. This can be increased to 15kV by the addition of an isolation transformer.

5kV isolation is usually acceptable for 11kV cable distribution systems where zero sequence currents are relatively low and protected feeder lengths and therefore parallel runs are relatively short. For higher voltages where longer feeder lengths are common 15kV insulation may be required but 5kV may be acceptable if fault levels are low or feeder lengths are short.

The pilot cores should be allowed to 'float' with neither core earthed at either end. Capacitive coupling to the local ground along the cable length will ensure that voltage at either end will cause the pilot voltage to remain symmetrical to the ground voltage such that the withstand requirement at each end is approximately half of the longitudinal induced voltage.

Induced voltage is proportional to parallel length, maximum parallel current and the coupling or screening factor between the pilot and the current path. This can be very difficult to assess accurately by calculation and cannot generally be measured.

The maximum current is generally accepted as the EARTH fault level for an out of zone fault. Although a phase-phase or 3-phase fault may have a higher fault current, the fault current for these faults will return locally in a parallel path in the opposite direction i.e. in the other phase(s). With an earth fault, the return path may be distant or non-parallel with the pilot such that the net current which couples to the pilot can be considered maximum for the earth fault. The through fault current level is used in combination with the total feeder length as a worst case scenario because although an internal fault may have a greater fault current, the parallel path will be shorter by definition.

5 Pilot Cables

The above considerations of insulation and balance between cores, it is evident that pilot cables for use with pilot wire current differential feeder protection are required to have special consideration when long lengths and high fault currents are involved. It is also apparent that the effects are not easily analysed or modelled and thus in-service experience is the most reliable basis in deciding which types of pilot will be satisfactory.

The UK has vast experience of the use of pilot wire differential feeder protection and the UK supply industry specification on multipair cables, ESI Standard 09-6 is therefore particularly applicable as a reference for pilot wire requirements.

It should be noted that the voltage between cores in the pilots is limited by the non-linear resistors which are connected across the summation transformers in the Solkor relays at the ends. Also note that any induced voltage will be at an equal level per unit length in all cores and screen. Thus it is possible to use pilots with 500V grade insulation between cores and core to screen. The 5 or 15kV insulation requirement exists only between 'internal cores and screen' to the local earth. Similar considerations should be observed at any cable terminations where standard 500V terminals can be used but the whole terminal block should be mounted on an insulating baseplate to comply with insulation requirements to the local ground. Terminals should be shrouded and clearly marked since during a system fault (included a fault on any parallel feeder, not only the protected circuit) the induced voltage may pose a serious risk to health. Inside of the protection panel, the insulation to local earth and segregation of wiring for health and safety purposes may be more easily achieved by the use of separate cable trunking which can be routed independently and clearly marked rather than by the use of special cabling inside of the panel. Special precautions will be required when terminating or handling pilot connections.

Pilot inter-core capacitance has the effect of shunting the relays in the current balance scheme. As the capacitance increases a point is reached where the shunt impedance has a significant effect on the relay settings. This produces a maximum limit for pilot capacitance which can be used with the relay. With the relays in the Solkor R connection mode the pilot capacitance maximum limit is 2.5 μ F and with the Solkor Rf connection mode this limit is 0.8 μ F. These limits can be increased for the Solkor Rf mode by the use of transformer tapings if the

15kV isolation transformers are used. The limits are 1 μ F, 2 μ F and 4 μ F which impose accompanying pilot LOOP resistance limits of 1760 Ω , 880 Ω and 440 Ω respectively.

The pilot resistance is used in conjunction with settable padding resistance to achieve the stability biasing of the relay. The padding resistance must be set in series with the pilot resistance to achieve a standard value. There is a therefore a maximum value for the pilot resistance for which the padding should be set to zero. The maximum value of pilot LOOP resistance for the Solkor R mode is 1000 Ω and for the Solkor Rf mode the maximum LOOP resistance is 2000 Ω . When 15kV isolation transformers in the Rf mode the maximum LOOP resistance will be reduced to 1760 Ω to compensate for the transformer winding resistance and if the transformer taps are used to compensate for the effects of pilot capacitance the maximum LOOP resistance is reduced further to values of, 880 Ω and 440 Ω depending on the tap used. The actual pilot resistance must be referred through the transformer at the chosen tap to give an equivalent pilot resistance value to which the padding should be added.

Thus the padding resistance $R = (Sv - Rp) / (2T)$

Where R_p = Pilot LOOP resistance

S_v = standard value

=1000 Ω for Solkor R mode ($T=1$)

=2000 Ω for 5kV Solkor Rf mode (without transformers) ($T=1$)

=1760 Ω for Solkor Rf with 15kV transformers using tap 1 ($T=1$)

=880 Ω for Solkor Rf with 15kV transformers using tap 0.5 ($T=0.5$)

=440 Ω for Solkor Rf with 15kV transformers using tap 0.25 ($T=0.25$)

6 Pilot Supervision

Pilot supervision is used to detect failure of the pilot connection. Open circuit Pilots will lead to a loss This is often applied as standard with the Solkor system but may considered unnecessary at lower voltages or in an interconnected system where unnecessary tripping of an un-faulted feeder may be tolerated due to limited consequences in terms of loss of supply and relatively low probability of pilot damaged or failure when compared to the additional equipment cost.

The Pilot Supervision system uses DC injection which cannot pass through a transformer. For this reason the Pilot Supervision must be applied at the pilot side of the 15kV isolation transformers if fitted and therefore the devices must have an isolation level to suit. The Send End unit and B75 Receive End must have 15kV insulation. The B22 Supervision Relay and B74 Repeat Relay are not connected to the pilots directly and no special isolation requirements apply to these devices.

7 Overcurrent Guard Relays

Overcurrent Guard relays are connected to the same CTs as the Solkor relay. The output contact is connected in series with the Solkor Rf such that a Solkor differential operation will not cause a CB trip if the current in the guard relay (and therefore the local end) is below setting. A separate Solkor contact should be wired an alarm to indicate that the pilots may be damaged. Care should be taken when applying guard relays that the fault infeed will be available to operate the guard relay. Application to radial systems may be limited.

Phase fault Guard relays should be set to at least 150% of maximum load current for stability but less than 50% of the minimum expected phase fault current. These 2 requirements may conflict and a compromise may be required.

Earth fault guard relays should be set to less than 50% of the minimum earth fault but more than 150% of the maximum residual expected due to load imbalance. It is important to note that if an electromechanical, variable setting relay is used as a guard relay, if a low setting is selected the AC burden at rating will be increased. This is not the case when a modern numerical relay is used as a Guard relay since this will have a fixed burden independent of the relay setting. The lower burden of the numeric relay may be a major advantage in this application.

If a numeric Overcurrent guard relay is used, a spare contact from the Solkor can be wired to a binary input of the Guard relay and used to trigger a waveform record such that the waveform recording for a Solkor operation is added to the scheme. This function can be extremely useful in identifying the cause of operations caused by pilot disturbance.

8 Injection Intertripping

Injection intertripping is used to force the remote end circuit breaker to trip for local protection operation. This is generally started by protection other than the Solkor system since a differential protection system will generally trip on differential current at both ends regardless of the local current level. Injection Intertripping functions by injecting AC onto the pilots to simulate a local single end fed fault detection which causes a remote end

differential trip. This achieves intertripping of the remote end circuit breaker without the requirement of a dedicated additional communications channel or intertrip receive equipment and associated trip relay at the remote end. Additional equipment (TEC/B34) is required to disconnect the local end relay and apply suitable delays to achieve the best attainable compromise of remote end operation time when the injection signal is compared to the full range of possible measured remote end current.

Injection Intertripping is generally difficult to apply successfully in conjunction with Overcurrent Guard relays since the remote Guard relay will block operations resulting from intertrip injection if the remote end CT current is below the Guard setting.

Inputs to the Injection intertripping are supplied for pulsed and sustained intertrip. A 2 second self resetting intertrip pulse is usually specified to operate the remote relay. A sustained intertrip is often specified to cause a persistent trip at the remote end which will stop auto-reclose and prevent manual close at the remote end for a fault which is identified as permanent at the local end.

When sustained intertripping is applied, the inverter output can be reduced to a level which will hold the remote Solkor in the operated condition, after the initial higher level has been used to ensure high speed operation. This Two Stage Intertripping is achieved by switching an external resistor into the inverter circuit after a 2 second time delay following an intertrip initiation. For this purpose a TEC relay with an additional 2s time delayed element providing a normally closed output contact is available. The connection arrangement is shown in the Diagrams section of this manual.

9 Capacitive Charging Currents

Significant electrical capacitance exists between HV primary conductors and the adjacent earth such that a capacitive charging current will exist with any energised line. The level of current is dependent on the system voltage, the feeder length and the construction including materials and proximity of earthed conductors. The highest levels are found in separate phase, individually screened and armoured conductors with lowest levels found on overhead line feeders. These currents are generally supplied from one end only as balanced 3 phase and as such constitute a differential current to the relays but is usually significantly lower than relay 3P setting.

During out of zone earth faults however, the voltage on the faulted phase may be significantly depressed such that the charging current is reduced. The Solkor summation transformer will measure charging current on two phases only and interpret this as a residual differential current for which relay settings are significantly lower than for 3P balanced differential current. This issue is compounded in systems which are not solidly earthed because the unfaulted phase voltage may increase, leading to increased charging current on these phases, during an earth fault. The transient switching of charging current limits the maximum charging current to 1/3 of the most sensitive earth fault setting for solidly earthed systems or 1/9 of the most sensitive earth fault setting for resistance earthed systems.

On higher voltage systems, where separate single phase cables are more commonly used and feeders are generally longer it is common to find phase segregated Solkor Rf systems where 3 separate Solkor relays are fitted at each end, each connected to a separate pairs of pilots with one phase of the system CT connected to each relay. This avoids the problem of summation of charging currents.

10N/N1 Setting

The N1 tap can be used to increase the relay sensitivity to earth faults by lowering settings for these faults without affecting the phase fault settings. This may be particularly desirable for the 15kV scheme where all settings are naturally raised by the increase in energy required to drive the additional isolation transformers. It must be noted that the use of the N1 tap will increase the burden on the CT and therefore should only be used if the CT knee point voltage V_k easily exceeds the minimum requirements stated below, which is often the case with modern CTs. Prior to the introduction of cold rolled iron in CT design, the CT magnetising current effects could cancel out any reduction in setting by increasing the excitation currents required at the higher level of relay burden. Care should be taken when applying the N1 tap to older designs of CT with limited V_k .

The Primary in Zone Capacitance may also limit the use of the N1 tap as loss of charging current may lead to mal-operation at the lower earth fault setting as described above.

11 In-Zone Tapped Load

The relay is able to tolerate a limited amount of tapped off balanced load within the zone of protection based on the relatively insensitive level of fault setting for balanced 3P differential current. The typical setting is 72% for 3P faults or differential load current. To allow for switching transients of the tapped load a factor of 3 is advisable. The steady state feeder charging current and CT inaccuracy will also erode the stability margin resulting in a maximum bleed off of 10-20% of rated load current. Zero sequence infeed during out of zone earth faults from

any transformer connected at the tapping point must be less than the minimum earth fault sensitivity of the relay at the feeder end. If a 20% tap off consists of a single large transformer, time lag relays may be required between the Solkor trip contact and the CB coil to improve stability by allowing for inrush conditions due transformer excitation.

If the feeder is teed at the substation, with an additional CT fitted to the tee-off, the two CTs should be connected in parallel. To minimise excitation caused by transient spill current the CTs should be connected by the shortest electrical path. Care should be taken in CT specification to ensure that CT mismatch or saturation is not significant for the out of zone fault path where the fault current is not limited by the protected impedance. Fault current passing in and out of the paralleled CTs will fail to cancel if the CTs are mismatched or if saturation occurs to different extents. This current may be higher than the through fault level upon which the CTs are usually sized.

12 Current Transformer Requirements

The main requisite is that the saturation voltage of the current transformers should not be less than that given by the formula:

$$V_k = \frac{50}{I_n} + \frac{I_F}{N} (R_{CT} + 2R_L)$$

Where I_n = Rated current of Solkor Rf relay.

I_F = Primary current under maximum steady state THROUGH FAULT conditions.

N = Current Transformer ratio.

R_{CT} = Secondary resistance of the current transformer

R_L = Lead resistance between the current transformers and the Solkor R/Rf, per phase.

For the above purpose the saturation voltage i.e. the knee point of the magnetising curve, may be taken as that point on the curve at which a 10% increase in output voltage requires 50% increase in magnetising current. To ensure good balance of the protection the current transformers at the two ends should have identical turns ratios. Close balance of the ratio is provided by current transformers to IEC60044: pt1, class px, whose ratio error is limited to $\pm 0.25\%$ and these CTs are recommended to meet the above requirements.

It is recommended that no other burdens should be included in the current transformer circuit, but where this cannot be avoided the additional burden should be added to those listed when determining the current transformer output voltage required.

In addition to the above, the secondary magnetising currents of the current transformers at different ends of the feeder should normally not differ by more than $I_n/20$ amperes for output voltages up to 50V where I_n = rated current of Solkor Rf relay. This criteria is applied to quantify matching of the transient response of the two CTs so that relay operations do not occur due to differing responses of the CTs to normal load switching or the incidence and clearance of out of zone faults. This condition is usually easily satisfied by modern CTs of similar size since the magnetising current is usually a lower value. Care should be taken when applying a new CT to be paired with existing CT and also when interposing CTs are required to match CT ratios.

The fault current used for the above calculation should be the THROUGH FAULT level. This condition must be considered to ensure that the relay will not be caused to operate for through faults due to secondary differential current being created by the failure of the CT to measure correctly due to core saturation. During a high level internal fault the relay will operate before the saturation effect becomes significant. The THROUGH fault level is often not readily available and may be significantly different to the source Busbar fault level which is commonly quoted incorrectly based on switchgear rating rather than on the actual current level which is limited by system impedances. The remote end fault level will be distorted by any parallel infeed or backfeed and is only equivalent to the through fault level for truly radial systems.

The following example shows a simple through fault current estimate based on Busbar levels and commonly available data.

Example

33kV Overhead line

10km long

$X_L = 0.28978$ ohms/km $R_L = 0.07765$ ohms/km (Primary)

CT ratio = 400:1

$R_{CT} = 2$ ohms

CT wiring resistance, R_L , 30m long 7/0.67mm 2.5mm sq. at 7.4 ohms/km = 0.22 ohms

VT ratio 33000:110V

Maximum X/R ratio at source busbar = 20

Maximum 3P fault level at busbar = 1000MVA

Consider 3P fault level based on maximum busbar levels.

$$V_{Ph} = 33000/\sqrt{3} = 19.05\text{kV}$$

$$\text{Fault level per phase} = 1000/3 = 333\text{MVA}$$

$$I_F = \frac{333 \times 10^6}{19.05 \times 10^3} = 17.5\text{kA}$$

$$Z_S = \frac{19.05 \times 10^3}{17.5 \times 10^3} = 1.089\Omega$$

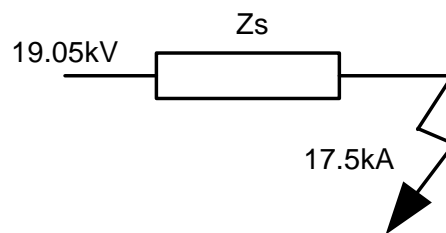

Also, since X/R at the busbar = 20,
We can evaluate the source impedance:

$$\theta = \tan^{-1}\left(\frac{X}{R}\right)$$

$$\theta = 87^\circ$$

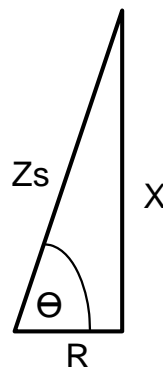

$$R_S = Z_S \cos \theta = 0.0544\Omega \quad \& \quad X_S = Z_S \sin \theta = 1.0876\Omega \quad (\text{Primary})$$

$$R_L = 0.07765 \text{ ohms/km (Primary)}$$

$$R_L = 10 \times 0.07765 = 0.7765\Omega \text{ (Primary)}$$

$$X_L = 0.28978 \text{ ohms/km}$$

$$X_L = 10 \times 0.28978 = j2.8978\Omega \text{ (Primary)}$$

Total impedance for a through fault at the remote busbar =

$$Z_S + Z_L = (R_S + R_L) + (X_S + X_L)$$

$$(0.0544 + 0.7765) + j(1.0876 + 2.8978)$$

$$Z_F = 0.8309 + j3.9854 \text{ ohms}$$

$$|Z| = \sqrt{R^2 + X^2}$$

$$|Z| = \sqrt{0.8309^2 + 3.9854^2}$$

$$Z_F = 4.071 \text{ ohms}$$

Through Fault Current =

$$I_F = \frac{19.05 \times 10^3}{4.071} = 4.68 \text{ kA}$$

Through fault current = 4.68kA compared to 17.5kA Busbar fault current due to the effect of the line impedance.

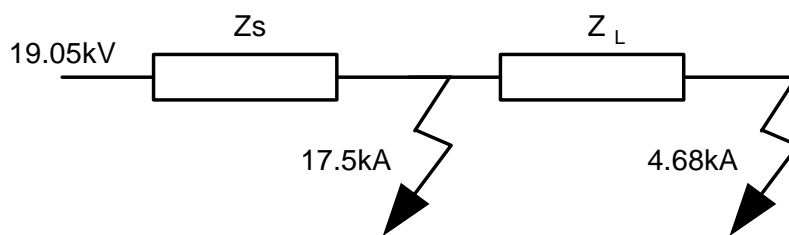

7PG21 Solkor Rf

Feeder Protection

Document Release History

This document is Version 2. The list of revisions up to and including this issue is:

02/2010	Document Reformat due to Rebrand
11/2009	Document Reformat due to Rebrand
08/2009	Technical update
07/2009	Format update
11/2007	Technical update

Software Revision History

--	--	--

The copyright and other intellectual property rights in this document, and in any model or article produced from it (and including any registered or unregistered design rights) are the property of Siemens Protection Devices Limited. No part of this document shall be reproduced or modified or stored in another form, in any data retrieval system, without the permission of Siemens Protection Devices Limited, nor shall any model or article be reproduced from this document unless Siemens Protection Devices Limited consent.

While the information and guidance given in this document is believed to be correct, no liability shall be accepted for any loss or damage caused by any error or omission, whether such error or omission is the result of negligence or any other cause. Any and all such liability is disclaimed.

Contents

1	Differential Protection settings	3
1.1	Protection Sensitivity	3
1.2	Pilot Resistance	3
2	Pilot Supervision.....	4

1 Differential Protection settings

1.1 Protection Sensitivity

Protection sensitivity is fixed, based on secondary current rating, with the only settable variable being the use of the N/N1 tap. Different sensitivity is applicable to different phases and fault types.

The following settings are shown as a percentage of rated current and are directly applicable to the local relay of a connected pair when subjected to current injection at the local end only.

Relays in R mode will typically have sensitivity similar to the settings quoted below as Nominal for the Rf mode.

If the local relay is injected in isolation i.e. with pilots disconnected, the operate level will be approximately 50% of the quoted value.

If Pilot Supervision is fitted, the settings will be increased by 20-50%.

In Rf mode the remote end relay will operate at a similar level to the local relay, typically within +-10% of quoted setting.

In R mode the remote end will typically operate at 2.5 times the local end setting.

Type of fault	Fault settings (% In)							
	Solkor Rf without isolating transformers				Solkor Rf with isolating transformers			
	Nominal		Typical		Nominal		Typical	
	N1 tap	N tap	N1 tap	N tap	N1 tap	N tap	N1 tap	N tap
R-E	16	22	18	25	22	31	25	35
Y-E	18	27.5	21	32	26	39	30	44
B-E	22	37	25	42	31	52	35	59
R-Y	110		125		155		177	
Y-B	110		125		155		177	
B-R	55		62		77.5		88.5	
3 P	63		72		89		101	

1.2 Pilot Resistance

The padding resistance is set by adding series resistance to that of the pilots to achieve a standard value. The total loop resistance required depend on the R or Rf mode selected and the tap position of the isolation transformers if they are used, see Applications Guide in this manual.

The link is fitted in the 'OUT' position to short out the resistor.

2 Pilot Supervision

There are no variable settings associated with the Pilot Supervision system.

7PG21 Solkor Rf

Feeder Protection

Document Release History

This document is issue 02/2010. The list of revisions up to and including this issue is:
Pre release

02/2010	Document reformat due to rebrand

Software Revision History

--	--	--

The copyright and other intellectual property rights in this document, and in any model or article produced from it (and including any registered or unregistered design rights) are the property of Siemens Protection Devices Limited. No part of this document shall be reproduced or modified or stored in another form, in any data retrieval system, without the permission of Siemens Protection Devices Limited, nor shall any model or article be reproduced from this document unless Siemens Protection Devices Limited consent.

While the information and guidance given in this document is believed to be correct, no liability shall be accepted for any loss or damage caused by any error or omission, whether such error or omission is the result of negligence or any other cause. Any and all such liability is disclaimed.

Contents

1	Unpacking, storage and handling	3
2	Recommended Mounting Position.....	3
3	Relay Dimensions	3
4	Fixings.....	3
4.1	Epsilon Cases.....	3
4.1.1	Crimps	3
4.1.2	Panel Fixing Screws	4
4.2	Vedette Cases	4
4.2.1	Crimps	4
4.2.2	Panel Fixing.....	4
4.3	Back of Panel cases	4
4.3.1	Crimps	4
4.3.2	Mounting arrangement.....	4

Table of Figures

Figure 1. E2 Case.....	5
Figure 2. E4 Case.....	5
Figure 3. E6 Case.....	5
Figure 4. Vedette C1½ Case.....	5
Figure 5. 15kV Transformer Outline & Mounting Arrangement	7
Figure 6. Intertripping Inverter Outline and Mounting Arrangement.....	7

1 Unpacking, storage and handling

On receipt, remove the relay(s) from the container in which it was received and inspect it for obvious damage. Check that the relay(s) is the correct model number and the rating information is correct. It is recommended that the relay is not removed from the case. To prevent the possible ingress of dirt, the sealed polythene bag should not be opened until the relay is to be used. If damage has been sustained a claim should immediately be made against the carrier and the local *Siemens* office should be informed.

When not required for immediate use the relay should be returned to its original carton and stored in a clean, dry place.

2 Recommended Mounting Position

The Solkor Rf relay has test points fitted for use during commissioning and routine testing and a mechanical flag as a visual indication of relay operation. The relay should be mounted onto the circuit breaker or panel at a level which allows the user easiest access to the relay functions.

Components which have 15kV isolated pilot connections are often mounted separately from the protection relay in a location more convenient for the connection to the incoming pilot cable and/or in the interest of safety. Connections to the relay can then be made at the lower 5kV insulation level with precautions and identification to suit.

3 Relay Dimensions

The Solkor Rf relay is supplied in an Epsilon size E6 case.

5kV Pilot Supervision Send and Receive End units are supplied in Epsilon size E4 case.

B22 Supply Supervision relay, B74 repeat relay for use with 15kV Receive relay (B75) and the B34 relay for Rf Intertripping are each supplied in an Epsilon size E2 case

Mechanical diagrams of the Epsilon case dimensions and panel cut-out requirements are shown in Figures 1-3.

15kV Send End, B75 Receive relays and the TEC intertripping relay are supplied in Vedette size 1 1/2V case. Mechanical diagrams of case dimensions and panel cut-out requirements are shown in Figure 4.

The Intertripping Inverter is supplied in a special case for back of panel mounting and Mechanical diagrams of case dimensions and mounting requirements are shown in Figure 5.

The 15Kv Isolation Transformer is supplied in a special case for back of panel mounting and Mechanical diagrams of case dimensions and mounting requirements are shown in Figure 6.

4 Fixings

4.1 Epsilon Cases

4.1.1 Crimps

M4 Ring tongued crimps with 90° bend are recommended.

4.1.2 Panel Fixing Screws

Typical mounting screw kit per Relay)

Consists of 4 off M4x10mm Screws

4 off M4 Nuts

4 off M4 Lock Washer

Typical rear terminal block fixing kit (1kit per terminal block fitted to relay) Consists of:

28 x M4, 8mm Screws

28 x M4 Lock Washer

4.2 Vedette Cases

4.2.1 Crimps

M5 Ring tongued crimps are recommended.

4.2.2 Panel Fixing

Vedette case mounting arrangement is shown in

4.3 Back of Panel cases

4.3.1 Crimps

M6 Ring tongued crimps are recommended.

4.3.2 Mounting arrangement

Case mounting arrangement is shown in Figure 5 & 6

Figure 1. E2 Case

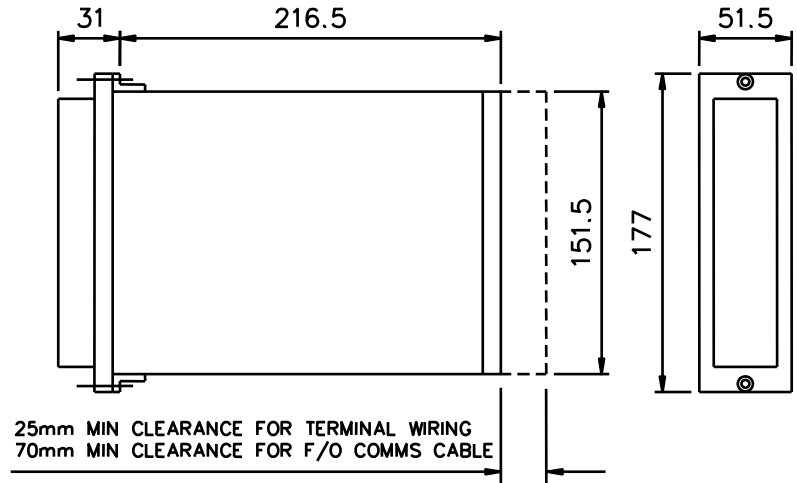
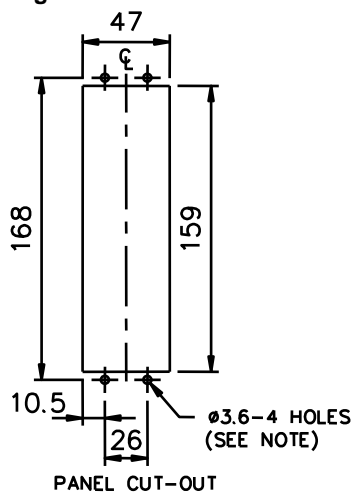

Figure 2. E4 Case

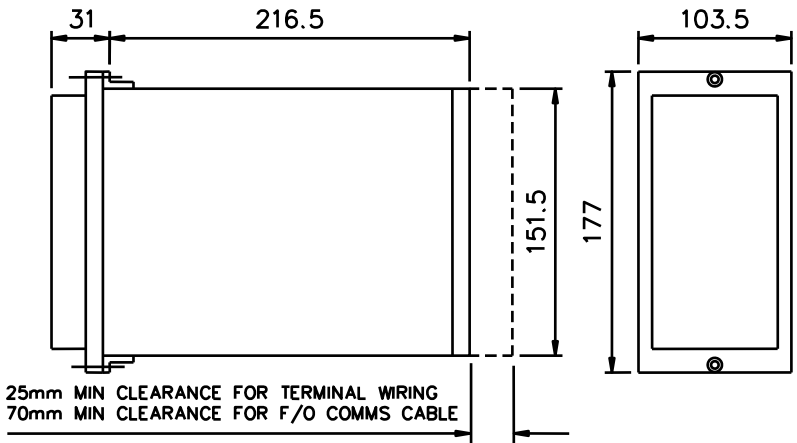
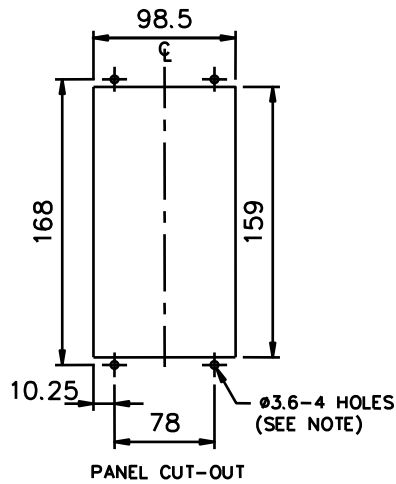
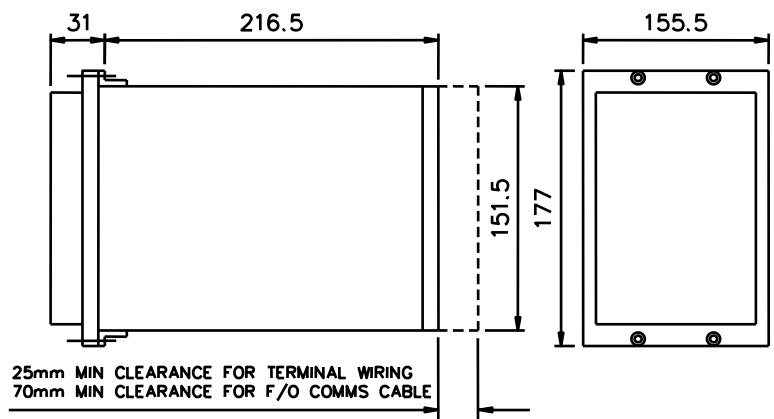
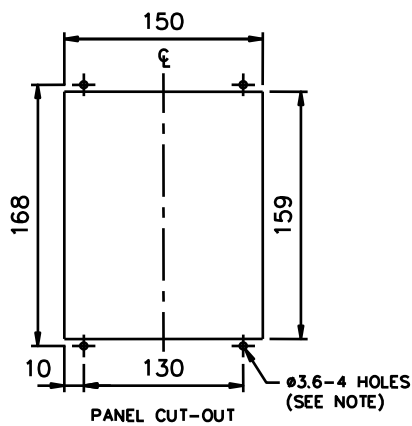

Figure 3. E6 Case



NOTE:
 THE ø3.6 HOLES ARE FOR M4 THREAD FORMING (TRILOBULAR) SCREWS. THESE ARE SUPPLIED AS STANDARD AND ARE SUITABLE FOR USE IN FERROUS/ALUMINIUM PANELS 1.6mm THICK AND ABOVE. FOR OTHER PANELS, HOLES TO BE M4 CLEARANCE (TYPICALLY ø4.5) AND RELAYS MOUNTED USING M4 MACHINE SCREWS, NUTS AND LOCKWASHERS (SUPPLIED IN PANEL FIXING KIT).

Figure 4. Vedette C1½ Case

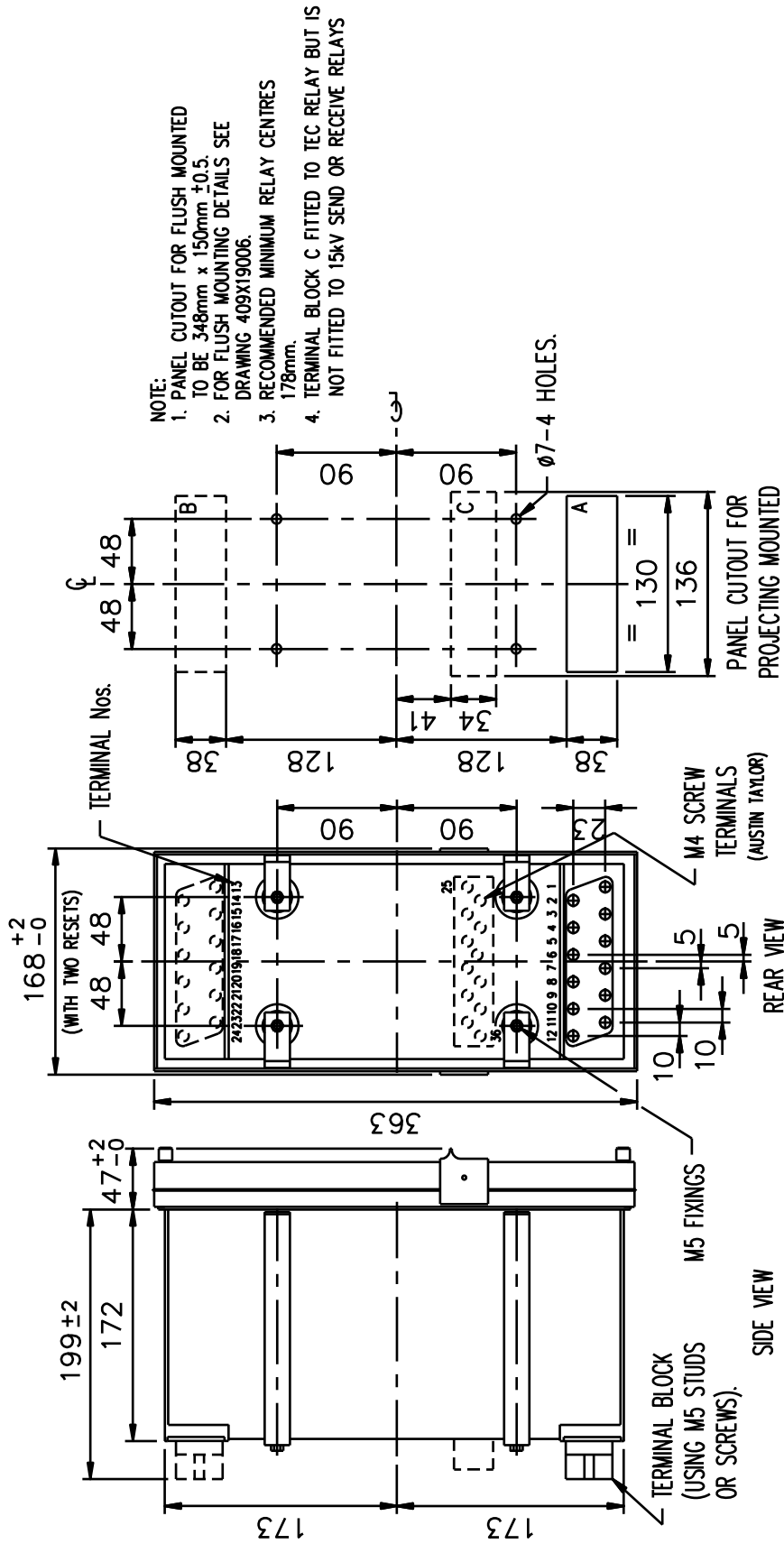

Figure 5. 15kV Transformer Outline & Mounting Arrangement

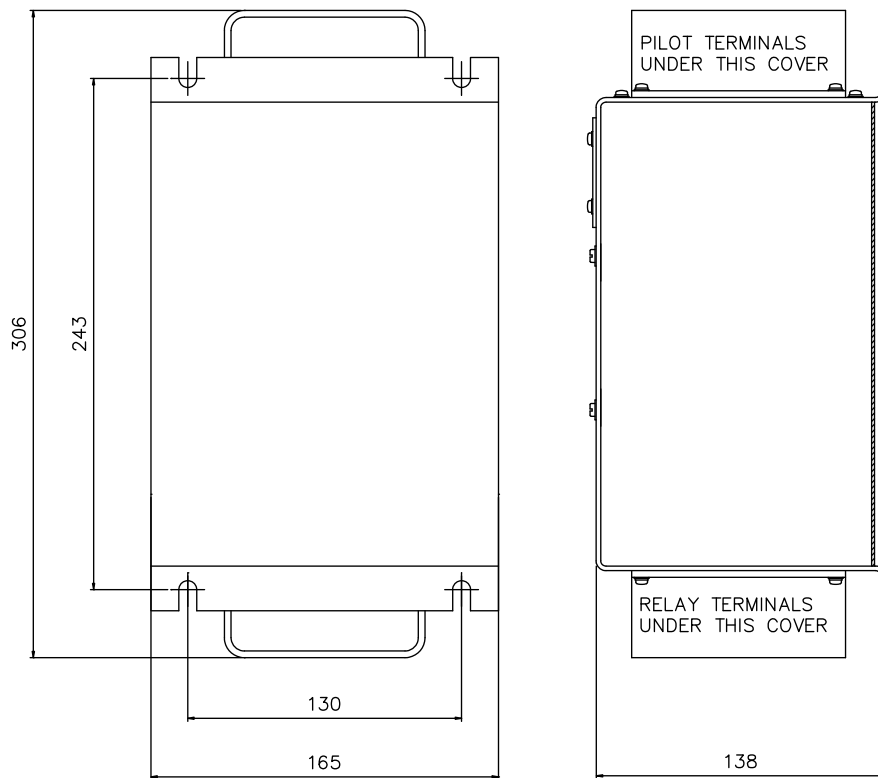
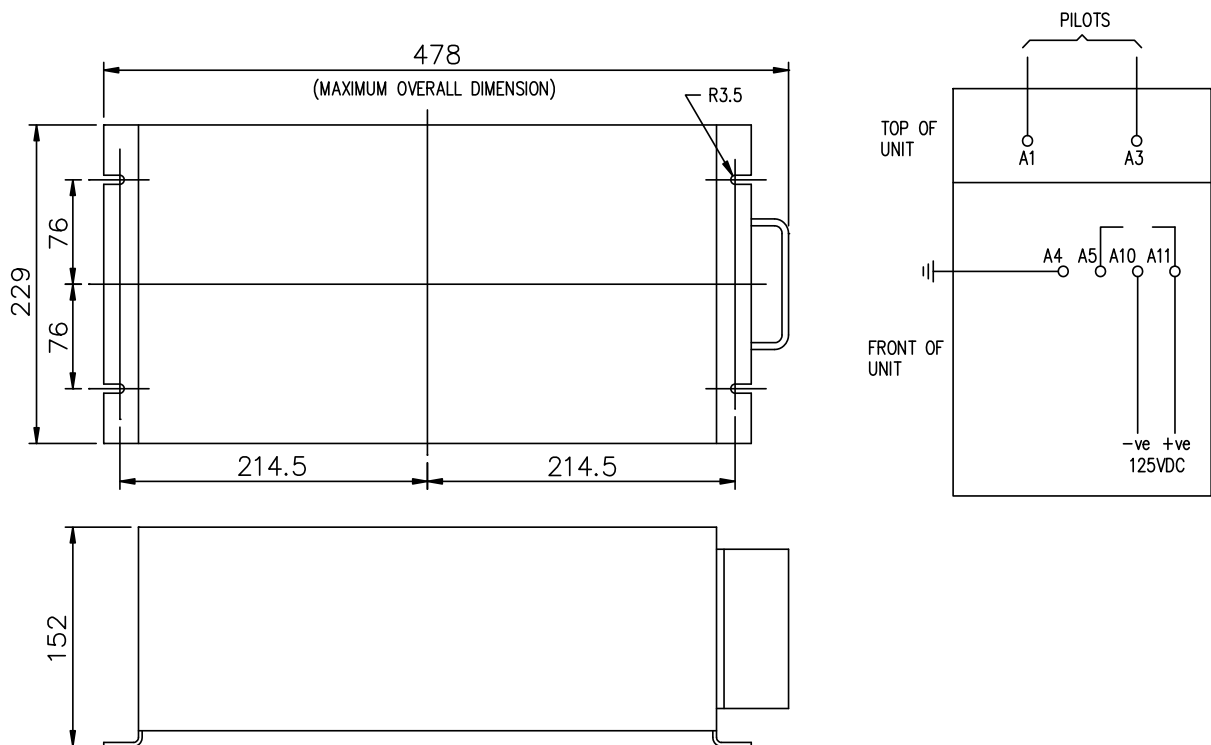

Figure 6. Intertripping Inverter Outline and Mounting Arrangement



7PG21 Solkor Rf

Feeder Protection

Document Release History

This document is issue 02/2010. The list of revisions up to and including this issue is:
Pre release

02/2010	Document reformat due to rebrand

Software Revision History

--	--	--

The copyright and other intellectual property rights in this document, and in any model or article produced from it (and including any registered or unregistered design rights) are the property of Siemens Protection Devices Limited. No part of this document shall be reproduced or modified or stored in another form, in any data retrieval system, without the permission of Siemens Protection Devices Limited, nor shall any model or article be reproduced from this document unless Siemens Protection Devices Limited consent.

While the information and guidance given in this document is believed to be correct, no liability shall be accepted for any loss or damage caused by any error or omission, whether such error or omission is the result of negligence or any other cause. Any and all such liability is disclaimed.

Contents

1	Introduction.....	3
2	Solkor R/Rf Relay.....	3
2.1	Test equipment required.....	3
2.2	Test programme	3
2.3	Precautions.....	3
2.4	Connection.....	3
2.5	Secondary wiring insulation-resistance test	4
2.6	Pilot Tests	5
2.6.1	Insulation-resistance test.....	5
2.6.2	Pilot-loop resistance tests	5
2.6.3	Pilot connection check.....	6
2.7	Overall fault-setting tests	6
2.8	Circuit-breaker tripping tests.....	8
2.9	Stability Tests	8
2.10	Alternative tests if primary injection equipment is not available	9
2.10.1	Check of fault settings by secondary injection	9
2.10.2	Current transformer ratio and polarity tests.....	10
2.11	Check of secondary connections	11
2.12	Putting into service	11
2.13	Operation	11
2.14	Solkor RF Relay – Connections for use in Solkor R Mode	12
3	Pilot Supervision Equipment	12
3.1	Introduction	12
3.2	Description of equipment.....	13
3.3	Commissioning Tests	13
3.3.1	Check of connections	13
3.3.2	Secondary wiring insulation resistance tests	13
3.3.3	Pilot tests.....	13
3.3.4	C.T. ratio and polarity	14
3.3.5	Overall fault setting tests.....	14
3.3.6	Check of pilots supervision receive relay	14
3.3.7	Test of guard relays (where fitted)	14
3.3.8	Test of pilot supervision supply failure relay (where fitted)	15
3.3.9	Overall tests of pilot supervision equipment.....	15
3.3.10	Stability tests	16
3.3.11	Putting into service	16
3.3.12	Notes	16
4	Solkor Intertripping	17
4.1	Introduction	17
4.2	Description.....	17
4.2.1	Open circuiting of pilots - Solkor-R and Solkor-Rf	17
4.2.2	DC injection intertripping	17
4.2.3	Injection intertripping - Solkor-R & Solkor-Rf	18
4.3	Commissioning.....	Error! Bookmark not defined.
4.3.1	Description of operation of TEC relay	19
4.3.2	Check on D.C/ A.C. inverter	19
4.3.3	Putting into Service	20

1 Introduction

This section details operating recommendations for Solkor R and Solkor Rf current differential pilot wire feeder protection. It also covers optional pilot supervision schemes and intertripping schemes.

2 Solkor R/Rf Relay

2.1 Test equipment required

The following equipment is required:-

- A 500V insulation-resistance test-set.
- A heavy-current transformer capable of injecting a minimum of 10 to 15% of C.T. rated primary current through the feeder.
- A secondary injection test set (0 -10A).
- An ammeter and a metering current-transformer for measuring primary currents.
- Three multi-purpose indicating instruments.
- An ohmmeter.
- 200 watt 2000 ohm resistor (DC to AC inverter test).

2.2 Test programme

Apply the tests in the order below:-

- Check of connections.
- Secondary wiring insulation resistance tests.
- Current transformer ratio and polarity tests.
- Pilot tests.
- Overall fault setting tests.
- Circuit breaker tripping tests.
- Stability tests.

2.3 Precautions

Do not open-circuit the secondary winding of a current-transformer while there is a current in its primary winding otherwise a high voltage will be produced in the secondary which may be dangerous to personnel and may also damage the secondary wiring insulation.

Check that all connections between the various pieces of equipment are in accordance with the appropriate schematic diagram and that all connections are tight.

Epsilon cases provide CT shorting between terminal 23-24, 25-26 and 27-28 as pairs. Although terminals 24-26-28 are linked internally within the relay, these terminals must be linked externally by panel wiring to prevent open circuit of current transformers if the relay chassis is withdrawn from the case. Check that this wiring is present.

2.4 Connection

Where isolating transformers are used the terminals connected to the pilots should be carefully checked to ensure that the same tap is used at each end. The protection should normally be connected on the N tapping. The N1 tapping should only be used where very low settings are required (e.g. in non-effectively earthed systems), and because of its greater sensitivity, care is necessary in the choice of current-transformers. It should be noted that the N1 tapping is not brought out to a terminal on the relay backplate, and if it is to be used the lead which is normally connected to the terminal N on top of the summation transformer should be connected to the adjacent N1 terminal.

Examine the relay giving special attention to the following points:

- Wipe off any dust from the outside of the relay and remove the cover.

- See that the armature and contacts move freely and that the flag indicates when the relay is operated by hand.
- Record particulars of any damage, repairs or adjustments found necessary.

2.5 Secondary wiring insulation-resistance test

This test should not include the pilots, which should be tested separately as described in "Pilot Tests". With all earth-connections, earth-links, and supply fuses and links removed, measure the resistance to earth of all the secondary wiring. Satisfactory values for the various readings depend upon the amount of wiring concerned. Where considerable multi-core wiring is involved, a reading of 2.5 to 3 megohms is satisfactory. For short lengths of wiring the readings should be higher. A value of 1 megohm should not normally be considered satisfactory.

Current-transformer ratio and polarity tests

If testing by single-phase primary injection is not possible, make the alternative tests detailed on page 7.

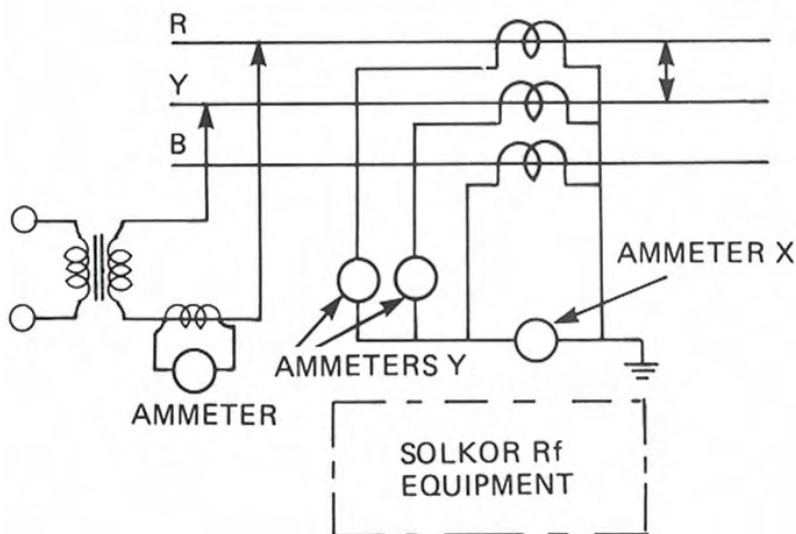

Fig 1(a)

Remove the trip-links. Connect the test-circuit as shown in Fig. 1(a) and inject a primary current of 50 per cent or more of the current transformer primary rating in order to obtain a reliable secondary-current reading. Check that the ratio of current transformer is correct by referring to the readings on ammeters Y. Also check that the polarity of the current-transformers, is correct by referring to ammeter X, the readings of which should be negligible compared with those in the individual phases. Repeat the tests for at least one other phase-to-phase fault condition.

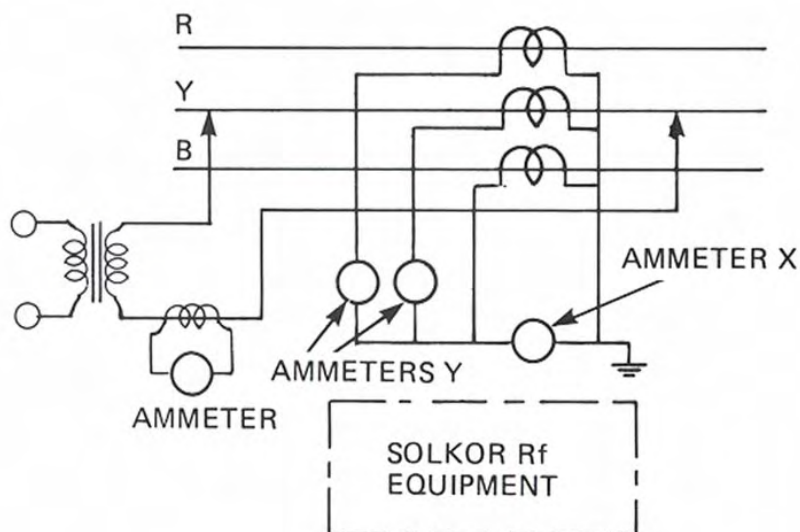

Fig 1(b)

Connect the test supply to simulate a yellow earth fault as shown in Fig. 1b. Inject a suitable value of primary current and check the readings on ammeters X and Y. The reading of ammeter X should equal the reading of the ammeter Y which is connected in the yellow phase C.T. secondary.

Repeat the tests at the other end of the feeder.

Tabulate the results as shown in Table 1.

Test condition	Primary current (amps)	Secondary current (A)			
		Red phase	Yellow phase	Blue phase	Neutral phase
Feeder end 1	R-Y				
	Y-B				
	Y only				
Feeder end 2	R-Y				
	Y-B				
	Y only				

Table 1 - C.T ratio and polarity tests

2.6 Pilot Tests

2.6.1 Insulation-resistance test

The voltage for the insulation-resistance test of the pilots should not exceed the nominal insulation level of the pilots, and the test should be made as follows:

With the pilots disconnected from the relay at both ends of the feeder, apply the insulation resistance test between the pilot cores, and between each core and earth. This test should be carried out with an insulation resistance test set. Compare the readings obtained with the value quoted by the manufacturer of the pilot-cable.

2.6.2 Pilot-loop resistance tests

With the pilots disconnected at both ends of the feeder, join the cores together at one end and measure the pilot-loop resistance from the other end. If the pilot loop resistance is less than the standard value for the particular arrangement being used (See Table 2) add padding resistance at each end. If isolating transformers are being used, choose the secondary tap to suit the measured pilot resistance. Thus for a pilot loop resistance lower than 440 ohms choose tap T1; for a pilot loop resistance between 440 ohms and 880 ohms choose tap T2; For a pilot loop resistance between 880 ohms and 1760 ohms choose tap F2. This will ensure that pilot capacitance will have a minimal effect upon the relay fault setting. The padding resistor comprises five series-connected sections, each section having a short-circuiting link. The values of resistance in the sections are 35 ohms, 65 ohms, 130 ohms, 260 ohms and 500 ohms. One or more sections can be inserted by removing the appropriate link or links which are located on the link-board. Choose the same value at each end.

It should be as near as possible to:

$$\frac{(SV-RP)}{2T}$$

where SV = Standard Value from Table 2
 RP = Pilot Loop Resistance
 T = Isolating Transformer Tap
 = 1.0 if no isolating transformer fitted
 = 1.0 for isolating transformer tapping F2
 = 0.5 for isolating transformer tapping T2
 = 0.25 for isolating transformer tapping T1

Table 2 shows the standard pilot loop resistance and maximum inter-core capacitance permissible for the various arrangements of Solkor. When isolating transformers are fitted it is recommended that, as a general rule, the tap chosen should be the one which allows the maximum value of pilot capacitance for the measured pilot loop resistance.

When inserting a padding resistance in Vedette case versions, the link should be completely removed on the Vedette case. Do not merely open-circuit the link by pivoting the link on one terminal and leaving it in this position, as this can reduce the insulation level between the padding resistor and earth. For Epsilon and Reymos case versions, the resistors are inserted by changing the plug position.

	Transformer former terminal	Transformer former tap value (T)	Standard value of pilot loop resistance (S.V.)	Maximum capacitance between cores F
Solkor R	-	1.0	1000	2.5
Solkor Rf without isolating transformers	-	1.0	2000	0.8
Solkor Rf with isolating transformers	F2	1.0	1760	1
	T2	0.5	880	2
	T1	0.25	440	4

Table 2 - resistance and capacitance limitations

2.6.3 Pilot connection check

If isolating transformers are not fitted check that relay terminals 17 at both ends of the feeder are connected by one pilot core and that relay terminals 18 at both ends of the feeder are connected by the other pilot core. For Vedette versions, terminal 5 corresponds to 18 and terminal 12 corresponds to 17.

Do this by disconnecting the pilots at both ends, earthing one core at the remote end and measuring the resistance to earth of each core at the local end. The pilot core giving the lower reading is the one which is earthed at the remote end. If isolating transformers are fitted check that transformers terminals S2 at both ends of the feeder are connected by one pilot core. Check that the other pilot core connects transformer terminal F2, T2 or T1 (depending upon which tapping is being used) at one end of the feeder to the equivalent transformer terminal at the other end of the feeder.

2.7 Overall fault-setting tests

If testing by single-phase primary-injection is not possible, make the alternative tests described on page 4.

The purpose of these tests is to establish the overall fault-settings of the protection and also to establish that the secondary wiring between the current-transformers and the summation transformer at each end is in accordance with the particular diagram supplied for the installation.

Remove the trip-links but ensure that the padding resistors are correctly set. Connect the test-supply initially to simulate a Red-earth fault-condition as shown in Fig. 2 and perform the tests in the following sequence.

Connect a d.c. milli-ammeter in the operating circuit of each relay as shown in Fig. 2.

On Epsilon cased relays, to perform this test, 4mm 'banana' plugs connected to the multipurpose ammeter (selected to DC milliamps) are required. Observe the polarity shown on the relay label. After connecting the meter, remove the test link.

On Reymos relays, test plugs 2109C99022 (Black) and 2109C99023 (Red) are required. Connect the red plug to the positive terminal of the multipurpose ammeter and the black plug to the negative. Remove the relay test link and insert the red plug in the top socket, the black in the bottom socket.

Slowly increase the test current until the local relay operates and record the primary and secondary currents. Check that the relay operating current is approximately 11 to 12 milliamperes and that the current in the relay operating circuit at the remote end is of the same order.

Repeat the test for the other earth fault conditions and also for the phase fault conditions if sufficient test current is available. Tabulate the results as shown in Table 3.

Type of fault	Measured fault setting (amps)				Relay operating current m/amps D.C.		Type of fault	Fault settings							
	Primary current		Secondary current					Solkor Rf without isolating transformers				Solkor Rf with isolating transformers			
	At end 1		At end 2		Nominal			Typical		Nominal		Typical			
	At end 1	At end 2	At end 1	At end 2	N1 tap	N tap		N1 tap	N tap	N1 tap	N tap	N1 tap	N tap		
R-E							R-E	16	22	18	25	22	31	25	35
Y-E							Y-E	18	27.5	21	32	22	31	30	44
B-E							B-E	22	37	25	42	31	52	35	59
R-Y							R-Y	110		125		155		177	
Y-B							Y-B	110		125		155		177	
B-R							B-R	55		62		77.5		88.5	
3 P							3 P	63		72		89		101	

Table 3 – test of fault settings

If it is convenient to permit operation of the circuit breaker at this stage, repeat one of the tests with the trip links inserted. Increase the primary current to the setting of the protection; the circuit breaker should then operate thus proving the tripping circuit.

Repeat the tests at the other end of the feeder.

When all the tests have been completed at both ends of the feeder, compare results between ends. Check that the most sensitive earth fault setting at each end refers to the same phase, i.e. the red phase, the next sensitive the Yellow phase and the least sensitive the Blue phase.

It should be noted that primary fault settings vary slightly with the current transformers used and the capacitance of the pilots. With average current transformers the fault settings at zero pilot capacitance are as given in Table 3. Values are expressed as percentages of relay rating.

Fault settings will be practically unchanged for pilot capacitance values between zero and approximately 80% of the maximum capacitance values specified in Table 2. Values of pilot capacitance higher than this have the effect of increasing the fault settings.

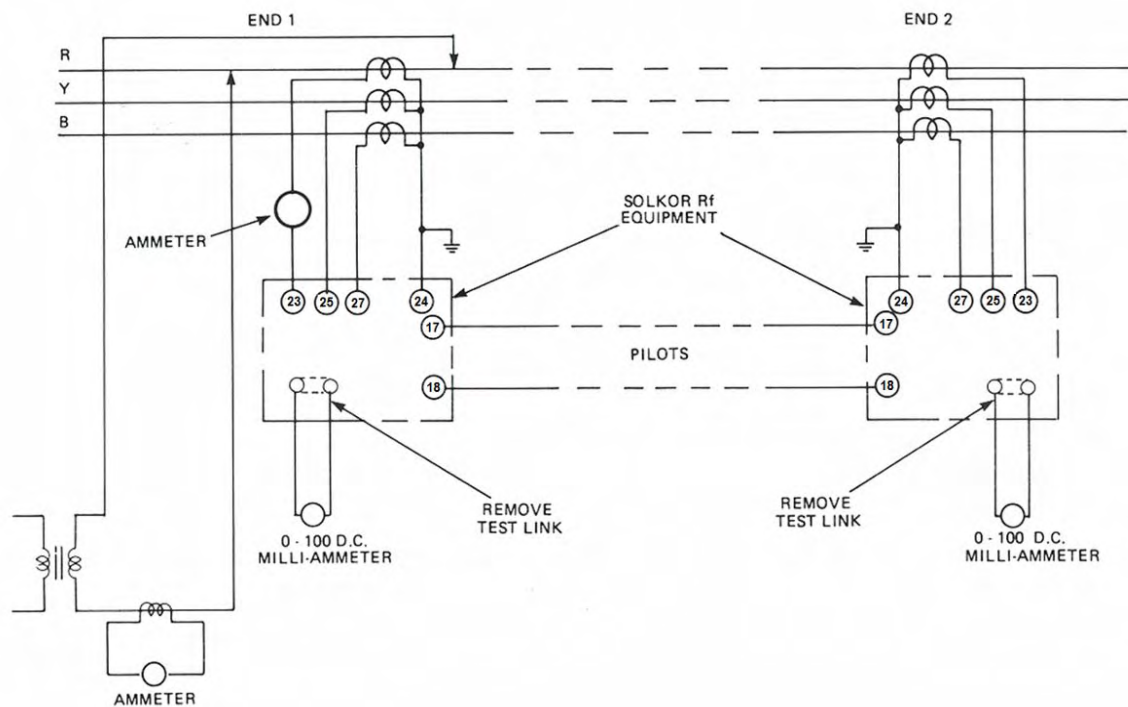

Fig.2 Connections for Overall Fault setting Tests by Primary Injection

2.8 Circuit-breaker tripping tests

If it has not been possible to make the tripping-tests described under "Overall fault Setting tests" perform the following test:

Insert the d.c. supply links and fuses, and operate the relay by hand; tripping should occur only when the trip-links are inserted.

2.9 Stability Tests

The purpose of these tests is to ensure that the pilots are correctly connected and that the current transformers at each end are starred correctly relative to one another in order to permit stabilisation of the protection under through fault conditions.

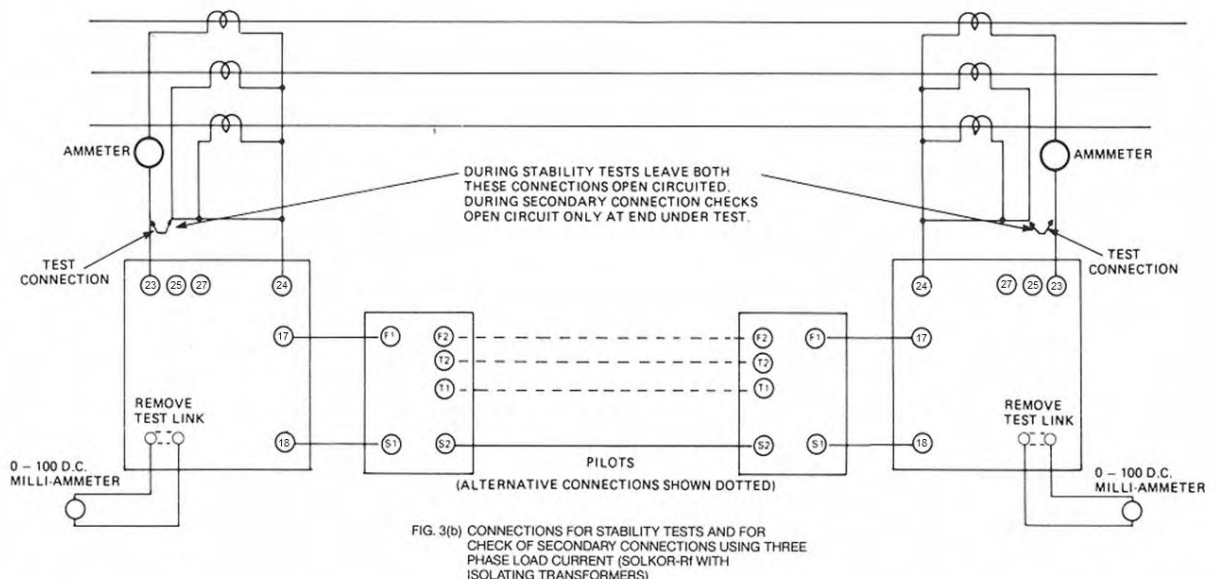
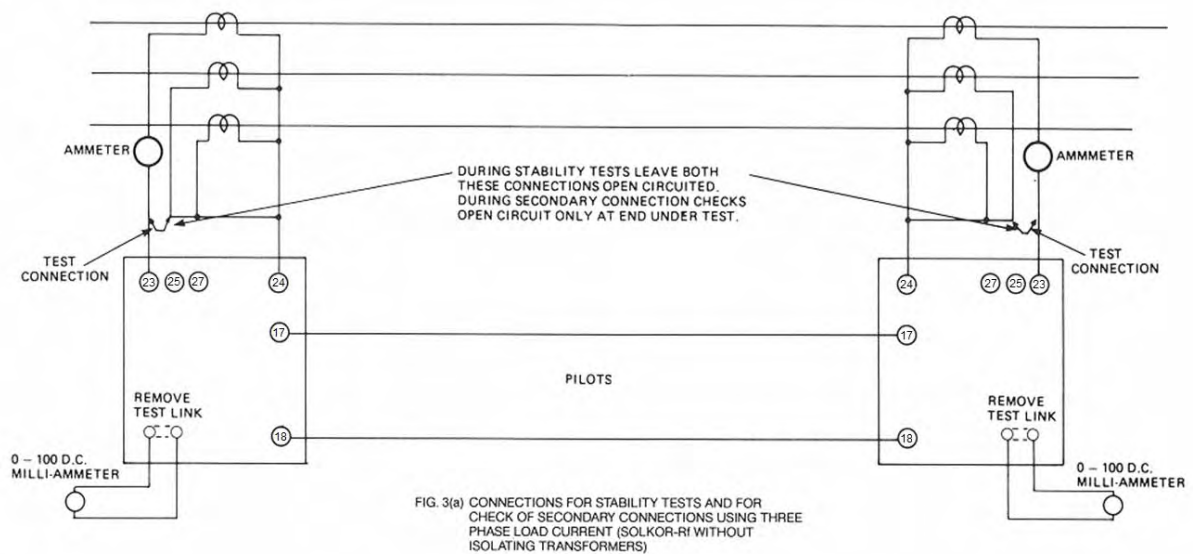

The test should be made with the load current in the feeder equal to at least 10 -15% of the rating of the feeder current-Transformers. Since in these tests all three phases of the primary circuits are energised, take care that the current-transformer secondary leads are not open circuited.

Remove the trip-links at both ends of the feeder but check that the remainder of the equipment, including the pilots, is connected for normal operation.

Connect the secondary circuit at both ends to simulate an external Red-Earth fault condition as shown in Fig. 3(a) (Solkor Rf without isolating transformers) or Fig. 3(b) (Solkor Rf with isolating transformers). Record the various current levels in the test circuit.

If the pilots and current transformers are correctly connected the d.c. current in the operating coils of the relays should be negligible.

If damage has been sustained a claim should immediately be made against the carrier and the local *Siemens* office should be informed.

Conditions of current transformers connections			Primary current (A)	Secondary current (A)	Tripping relay (mA d.c.)
Feeder ends 1	R-E	Normal			
		Reverse			
	Y-E	Normal			
		Reverse			
	B-E	Normal			
		Reverse			
Feeder ends 2	R-E	Normal			
		Reverse			
	Y-E	Normal			
		Reverse			
	B-E	Normal			
		Reverse			

Table 4 - stability tests

Reverse the leads to terminals 10 (23) and 7 (28) at one end of the feeder to simulate an internal Re-Earth fault. Alternatively reverse the pilot connections at one end of the feeder to unbalance the protection.

Check that there is a large increase of d.c. current in the operating coils of the relays.

If required repeat these tests for the other phase to earth conditions. Record the results for each end of the feeder as shown in Table 4.

2.10 Alternative tests if primary injection equipment is not available

If it is not possible to do the primary injection tests described under "Overall Fault Setting Tests" and "Current Transformer Ratio and Polarity Tests" then the relay operation should be checked by secondary injection and the C.T. ratio, polarity and the correctness of secondary connections should be checked using three phase load current as described below.

When doing tests using three phase load current take care to ensure that the current transformer secondary leads are never open circuited when current is passing through the primary.

2.10.1 Check of fault settings by secondary injection

Remove the trip links and C.T. earth links. With all the equipment including the pilots connected for normal operation, arrange the test circuit as shown in Fig. 4. Slowly increase the test current until the local relay operates and record the value of test current. Check that the relay operating current is approximately 11 milli-amperes and that the current in the relay operating circuit at the remote end is of the same order.

Repeat the tests for the other earth fault conditions and also for the phase fault conditions. Tabulate the results as shown in Table 3.

If it is convenient to permit operation of the circuit breaker at this stage, repeat one of the tests with the trip links inserted. Increase the test current to the setting of the protection; the circuit breaker should then operate thus proving the tripping circuit.

Repeat the tests at the other end of the feeder.

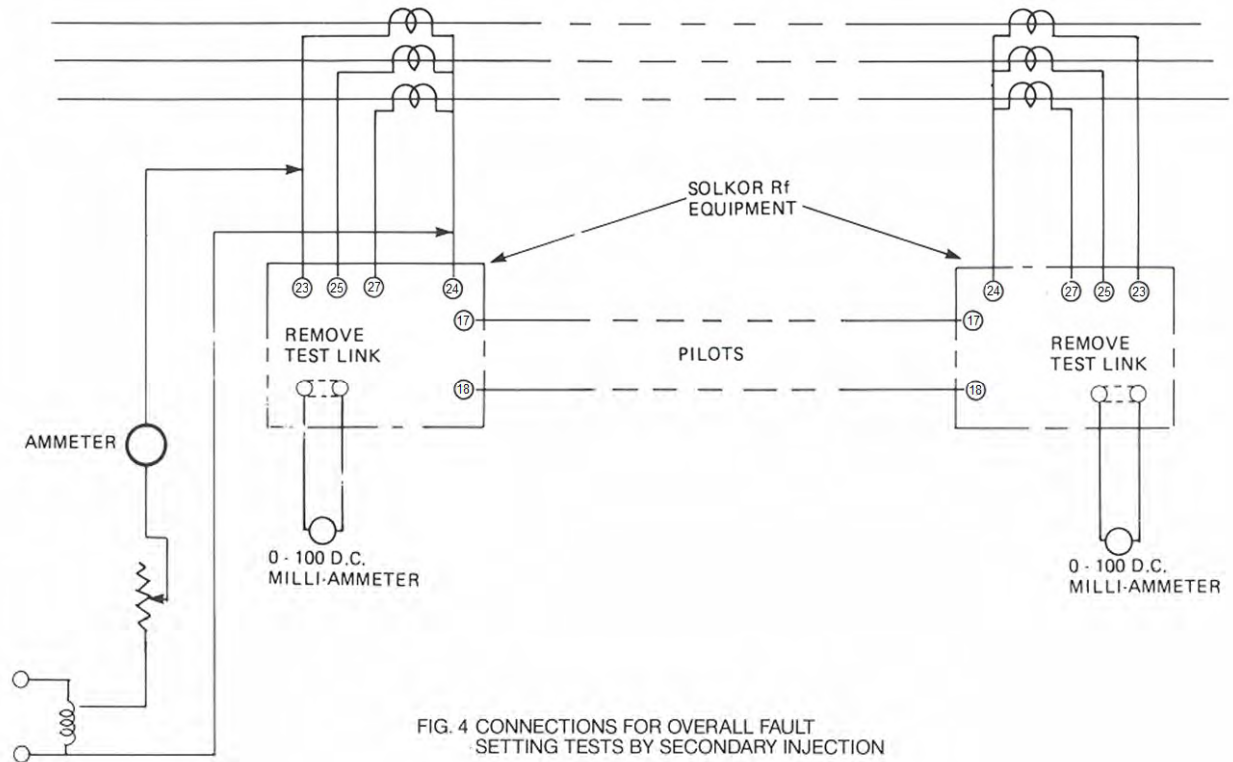

2.10.2 Current transformer ratio and polarity tests

Remove the trip links at both ends of the feeder. Connect ammeters in the current transformer secondary leads at each end in turn, as shown in Fig. 5. Pass three phase load current through the primary and check the ratio of each current transformer by comparing the secondary current in each phase with the corresponding primary current. Check the polarity of the current transformers; the reading of ammeter X in the neutral circuit should be negligible compared with the secondary phase-currents. Some current may exist in the neutral circuit due to unbalance of primary load current and/or secondary burden.

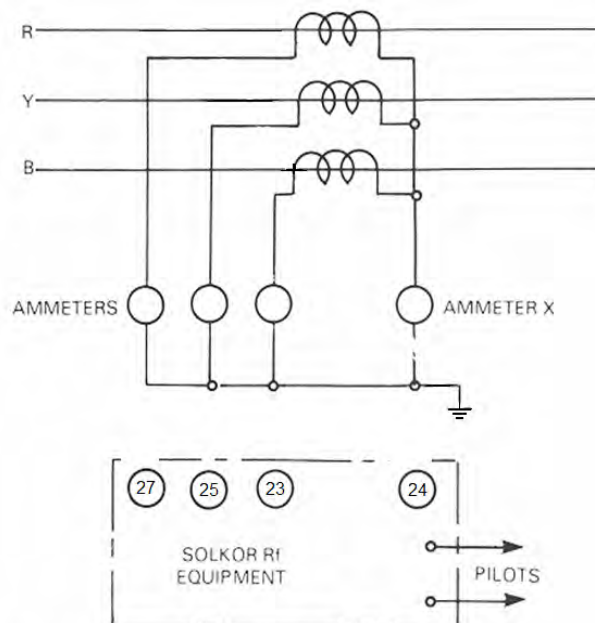

2.11 Check of secondary connections

The purpose of these tests is to establish that the secondary wiring between the current-transformers and the summation-transformer at each end is in accordance with the particular diagram supplied for the installation. However, if load-current is to be used it is unlikely that actual setting-values can be obtained in which event it is considered reasonable if suitable readings can be taken to confirm that the feeder ends behave similarly for the same fault-condition. Care should be taken that there is a reasonable value of load current available i.e. 25% to 50% of nominal.

Remove the trip-links. Check that the pilots are connected at each of the feeder and that the padding resistors are correctly set. In order to obtain comparable readings at each end the primary-current should remain constant. When using load-current this condition can best be approached by taking readings for a given fault-condition at each end in turn. With this object in view, initially connect the secondary circuit at each end as shown in Fig. 3a (Solkor Rf without isolating transformers) or Fig. 3b (Solkor Rf with isolating transformers). For a Red-Earth fault-condition remove the short-circuiting connection from the Red-phase current-transformer at the end of which the first readings are to be obtained. Measure the current in the operating-coil of the relay at this end, also the primary and secondary currents, and record the readings. Replace the short-circuiting connection across the Red-phase current-transformer, and repeat the above procedure at the other end to obtain comparable readings for the Red-Earth fault-conditions.

In a similar manner, by suitably connecting the current-transformer secondary leads at each end, obtain alternate readings at each end for the Yellow-Earth and Blue-Earth fault-conditions. Tabulate the results as shown in table 5 and compare results between ends.

Type of fault	Primary current (A)	Secondary current (A)	Tripping relay current (mA d.c.)	
			Feeder end 1	Feeder end 2
R-E				
Y-E				
B-E				

Table 5 - check of secondary connections using 3 Phase

2.12 Putting into service

To put the equipment into service, perform the following sequence of operations at each end of the feeder.

Insert the supply links and fuses.

Make a final inspection to ensure that the equipment is ready for automatic tripping. In particular check that the flag-indicator is re-set, that the metering test-link of each relay is firmly inserted and that all connections are tight. Finally, insert the tripping links, the protection is then ready for service.

2.13 Operation

No action is required in the event of a fault on the primary circuit external to the protective zone. On clearance of an internal fault the relay should automatically reset, but the flag-indicator would require to be reset by hand. It should only be reset after the fault has been logged.

Type of case	Diagram	R	Y	B	N	P0	P1	Contact 1	Contact 2	Contact 3
E6 Epsilon	2651W50006	23	25	27	24	17	18	1 3	2 4	6 8
1p Vedette (2M)	2651W10020	10	9	8	7	12	5	1 2	3 4	–
1p Vedette (3M)	2651W10110	10	9	8	7	12	5	1 2	3 4	15 16
R6 Reymos (2M)	2651W10127	23	27	25	24	17	18	1 3	2 4	–
R6 Reymos (3M)	2651W10123	23	27	25	24	17	18	1 3	2 4	6 8

R6 Reymos from 3/90	2651W10141	23	25	27	24	17	18	1	3	2	4	6	8
R4 CEE	2651W10120	2	6	10	15	19	21	16	13	9	8	—	

Table 6 - Terminal numbers of various types of Solkor-Rf relays

Maintenance

The maintenance test required will largely depend upon experience and site conditions; but it is recommended that the inspection and tests under "Check of Connections", "Secondary Wiring and Insulation Resistance Tests", "Pilot Tests" and "Overall Fault-Setting Tests", be performed every twelve months.

2.14 Solkor RF Relay – Connections for use in Solkor R Mode

Solkor-Rf relays can be connected for operation in the Solkor-R mode. This can be used with Solkor-Rf relays at both feeder ends, or with a Solkor-Rf relay at one end and a Solkor-R at the other. This latter instance will often occur when extensions are made to existing installation. Tests described in the Operating Recommendations for Solkor-R relays are appropriate to Solkor-Rf relays connected in the Solkor-R mode.

Before commissioning a Solkor-R relay it must be checked to determine that it is correctly connected for the chosen mode of operation. This is done by withdrawing the relay element from the case and inspecting four connections to a terminal block, as shown in the following illustrations.

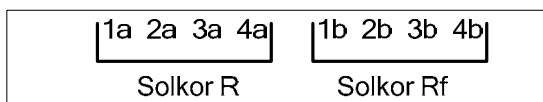

For Solkor R Mode:

Wires numbered 1, 2, 3 and 4 have to be connected to terminals 1a, 2a, 3a and 4a respectively.

For Solkor-Rf Mode:

Wires numbered 1, 2, 3 and 4 have to be connected to terminals 1b, 2b, 3b and 4b respectively.

Notes

- 1) To operate a Solkor-Rf relay in the Solkor-R mode it is also necessary to change the internal terminal block connections and also link external relay terminals 18 and 20 (Epsilon and Reymos) or 20 and 21 (C.E.E.) or 5 and 11 (Vedette) cases.
- 2) When operating in the Solkor-R mode the maximum pilot loop resistance is 1,000 Ohms.
- 3) From March 1990 Reymos modular cases had the current transformer connections R-Y-B to terminals 23, 25 and 27 Respectively.

3 Pilot Supervision Equipment

3.1 Introduction

Prior to 1988 pilot supervision was only available in the Vedette drawout case and this equipment was manufactured suitable for 15kV Insulated pilot circuits. Thus it can be applied to both 5kV and 15kV schemes. Since 1988 it is now possible to purchase pilot supervision in Epsilon modular cases, however these cases are restricted for use on 5kV insulated pilot circuits.

3.2 Description of equipment

The supervision equipment comprises:-

- a) At the supervision supply end:-
 - One transformer - rectifier supervision supply unit
 - One supervision supply failure relay (if required)
- b) At the supervision receive end:-
 - One pilot supervision receive relay
 - One pilot supervision receive repeat relay

For the 5kV scheme in the Epsilon modular case system, both elements are combined into one size E4 case.

- c) On some installations guard relays are fitted to prevent tripping of the circuit breaker should the Solkor protection operate under load conditions due to the pilots becoming open circuited.

The operating coils of the guard relays are connected in series with the summation transformer at each end of the feeder and the contacts of the guard relays are in series with the Solkor tripping contacts.

The setting of the phase fault guard relays should be lower than one half of the minimum phase fault current available and higher than the maximum available load current.

The setting of the earth fault guard relay which is connected in the neutral lead of the C.T.'s should be lower than one half of the minimum earth fault current available.

A typical Solkor Rf installation using pilot wire supervision and guard relays is shown in Fig. 8

3.3 Commissioning Tests

Preferably do the tests in the order given below:-

- Check of Connections
- Secondary Wiring Insulation Tests
- Pilot Tests
- C.T. Ratio and Polarity Tests
- Overall Fault Setting Tests
- Tests of Pilot Supervision Relays
- Overall Tests of Pilot Supervision Equipment
- Stability Tests

3.3.1 Check of connections

Make a general check of connections as described in the appropriate Operating Recommendations.

3.3.2 Secondary wiring insulation resistance tests

Check the insulation resistance of the secondary wiring as described in the appropriate Operating Recommendations.

3.3.3 Pilot tests

Before doing these tests, ensure that the pilot supervision relay and the transformer-rectifier supervision supply until are disconnected from the pilots.

Follow the procedure described in the appropriate Operating Recommendations to check the pilot Insulation resistance, the pilot loop resistance, the correctness of the pilot connections and to select a suitable value of padding resistor.

3.3.4 C.T. ratio and polarity

Check the current transformers for ratio and polarity as described in the appropriate Operating Recommendations.

3.3.5 Overall fault setting tests

Fitting pilot supervision to Solkor R or Rf protection affects the overall fault setting. The change in setting is influenced by several factors, eg. whether the relay is connected in the Solkor R or Solkor Rf mode, whether isolating transformers are fitted, the value of pilot capacitance current and in some cases the end from which the fault is fed.

As a general guide for Solkor Rf protection, one could expect the fault setting to increase by between 20 to 50%. For Solkor R protection (or Solkor Rf protection connected in the Solkor R mode) a similar increase in setting can be expected at the local end but the remote end setting decreases and both local and remote ends will trip at approximately the same value.

Due to this variation in fault setting, it is most important that the tests described in the Operating Recommendations under the heading "Overall fault setting tests" should first of all be done without the pilot supervision in service. This will not only check the basic fault setting but also confirm that the connections to the summation transformer at each end of the feeder are correct thus ensuring that the protection will stabilise correctly for external faults.

At the supervision receive end disconnect the supervision receive relays from the pilots and connect temporary links in the pilots to complete the pilot loop.

Do the overall fault setting tests at both ends of the feeder as described in the appropriate section of the Operating Recommendations.

If guard relays are fitted and sufficient test current is available the setting of the guard relays may also be checked by primary injection.

If it is convenient to permit operation of the circuit breaker at this stage, repeat one of the tests with the trip links inserted. If guard relays are fitted check that the circuit breaker will not trip until both the guard relay and Solkor relay have operated.

At the conclusion of the tests, remove the temporary links from the pilots and re-connect the transformer-rectifier supply unit and the supervision receive relay in the pilot loop.

The pilot supervision supply may be switched on and, if desired, the overall fault settings re-checked with the supervision equipment in service. Tests of pilot supervision relays

3.3.6 Check of pilots supervision receive relay

Disconnect the pilot supervision receive relay from the pilots and using the test circuit shown in Fig 7a check the pick-up and drop-off value of the relay.

The pick-up value of the relay should not exceed 3.5 milli-amperes.

The drop-off value of the relay should be less than 1.5 milli-amperes.

3.3.7 Test of guard relays (where fitted)

If it has not been possible to check the operation of the guard relays by primary injection then the following tests should be done.

Connect a temporary short circuit across the CT's at both ends of the feeder. Disconnect the red phase guard relay from the CT secondary at one end of the feeder.

Using the test circuit shown in Fig. 7b, check the pick-up value of the relay at the chosen setting.

Slowly reduce the current until the relay resets. The rest value should be greater than 75% of the pick-up value.

Repeat these tests for all the guard relays at both ends of the feeder.

At the conclusion of the tests, re-connect the guard relays on the C.T. secondaries and remove the short circuit from the C.T.'s at both ends of the feeder.

3.3.8 Test of pilot supervision supply failure relay (where fitted)

Disconnect the supervision supply failure relay from the transformer-rectifier supervision supply unit.

Using a variable a.c. voltage supply, check the pick-up value of the relay.

Slowly reduce the voltage until the relay resets.

The pick-up value of the relay should be approximately 80% of nominal rating.

3.3.9 Overall tests of pilot supervision equipment

Check that the pilot supervision equipment is connected correctly to the pilots and that all other connections are normal.

Connect a d.c. milli-ammeter in series with the pilot supervision relay.

Check that the a.c. supply to the transformer rectifier supply unit is connected to the correct transformer tapping.

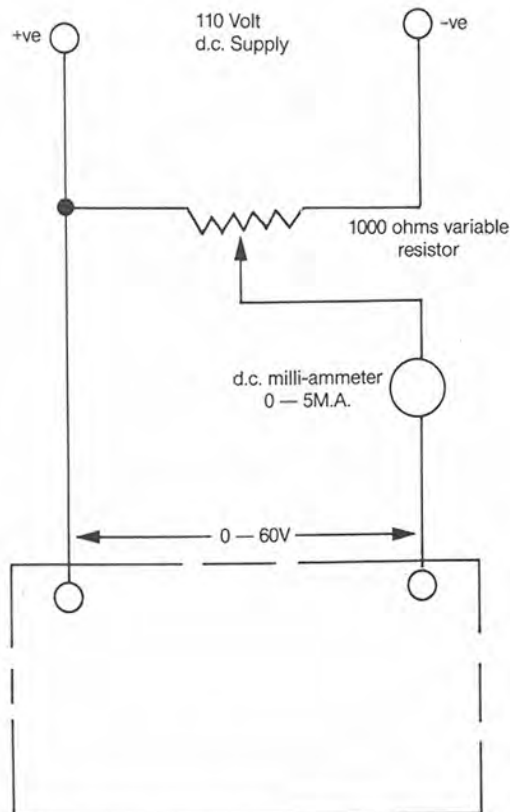

FIG. 1 SECONDARY INJECTION TEST OF PILOT SUPERVISION RECEIVE RELAY

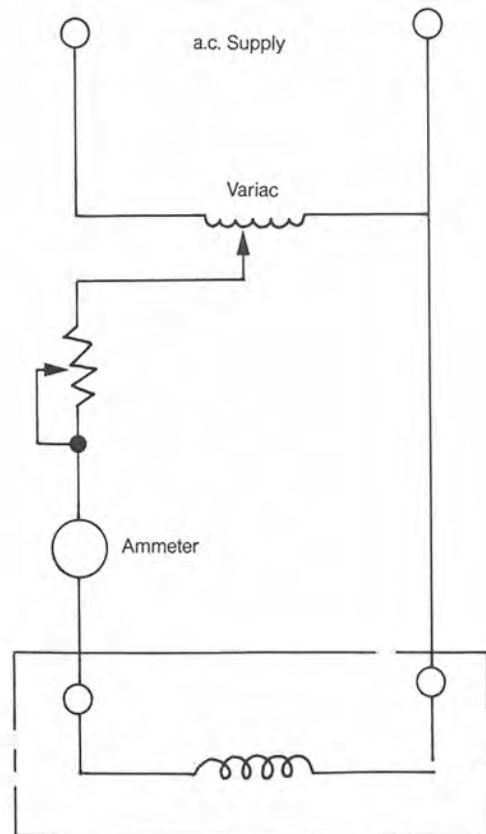

FIG. 2 SECONDARY INJECTION TEST OF GUARD RELAYS. (REFER TO RELEVANT SCHEMATIC FOR TERMINAL NOS.)

Switch on the a.c. supply to the transformer rectifier supply unit.

Check that the pilot supervision receive relay operates and that the current recorded by the d.c. milli-ammeter in the pilots is not less than 4 milli-amperes.

Check the correct operation of the scheme by doing the following tests:-

- a) **Short circuit the pilots and check that the pilot supervision receive relay and its follower relay reset and that a correct pilot failure alarm is given.**
- b) Open circuit the pilots and check that the pilot supervision receive relay and its follower relay reset and that a correct pilot failure alarm is given.
- c) Reverse the pilots at one end of the feeder and check that the pilot supervision receive relay does not pick-up and that a correct pilot failure alarm is given. Check that the current recorded by the d.c. milli-ammeter in the pilots is less than one milli-ampere.

Remove the d.c. milli-ammeter from the pilots and restore all connections to normal.

3.3.10 Stability tests

Check the stability of the protection as described in the appropriate Operating Recommendations.

3.3.11 Putting into service

Make a final check of connections. Ensure that the supervision supply is switched on, that the pilot supervision receive relay and repeat relay are held operated and that all indications and alarms are reset.

Make the checks described under the heading "Putting into service" in the appropriate Operating Recommendations.

Finally insert the tripping links.

3.3.12 Notes

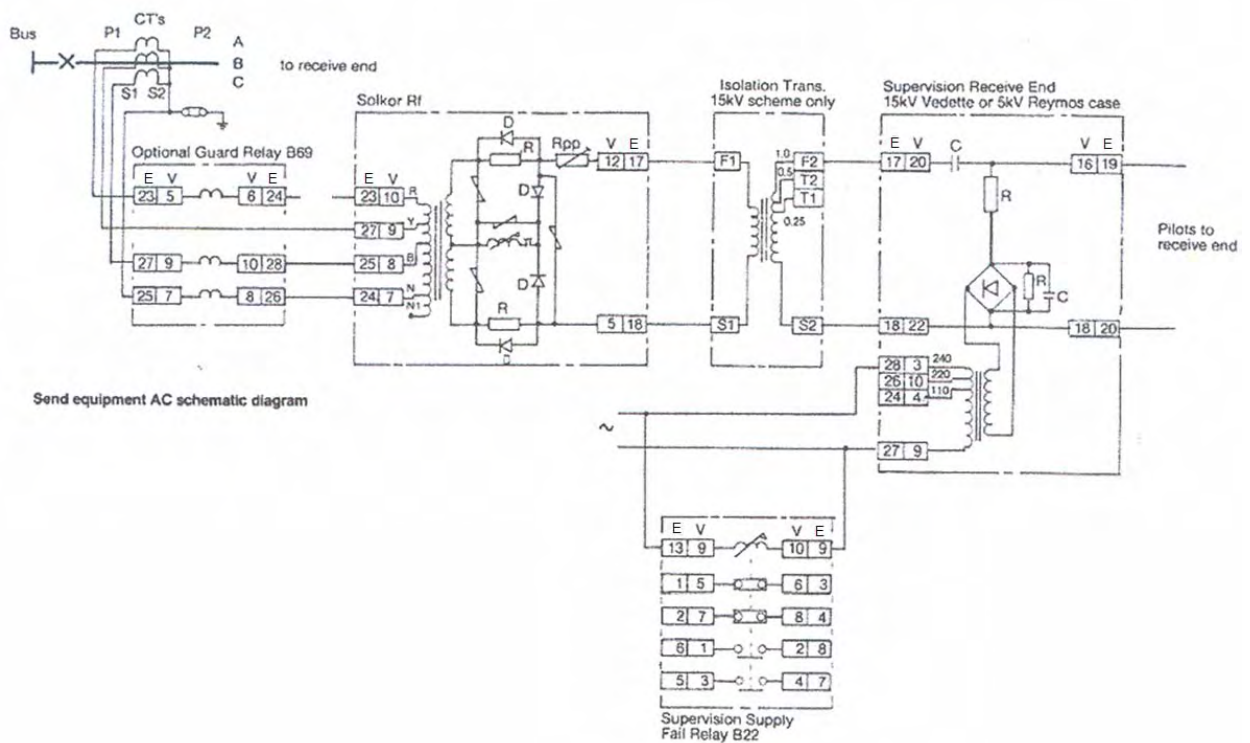

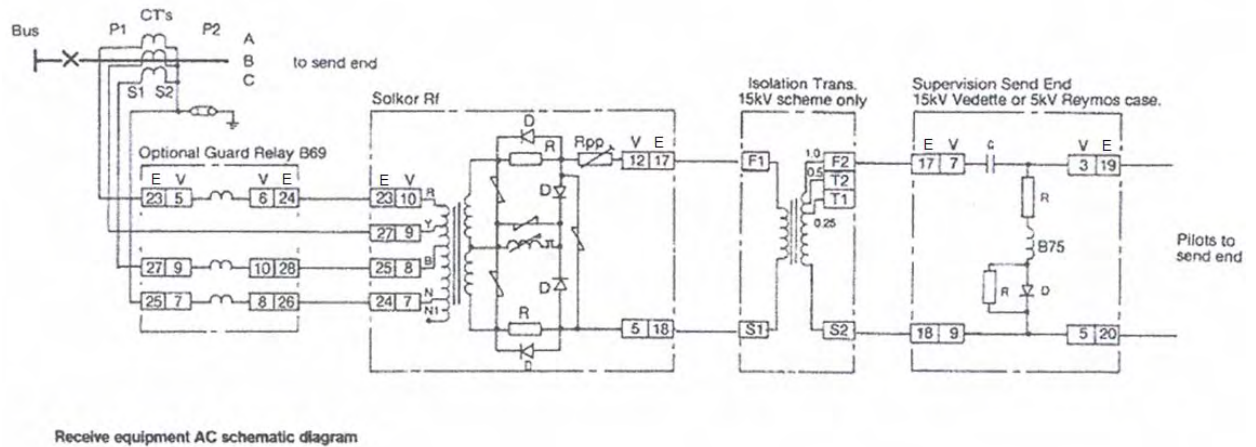

Receive equipment AC schematic diagram

Current transformer connections are typical only.

Earthing connections are typical only.

5kV Solkor Rf schemes omit the 15kV isolating transformers

Solkor R connections are shown in the relay Installation Recommendations.

An "E" above the connections indicates the Epsilon or Reymos case terminal numbers.

A "V" above the connections indicates the Vedette case terminal numbers.

4 Solkor Intertripping

4.1 Introduction

Solkor provides double ended tripping for in-zone faults. Use can also be made of the Solkor pilot link, and the remote Solkor relay, to intertrip the remote circuit breaker to clear faults external to the Solkor protective zone for example to backtrip from a busbar or transformer protection. There are several possible methods available, the choice between them being dependent upon the current available through the protected feeder for the fault conditions which required Intertripping.

4.2 Description

4.2.1 Open circuiting of pilots - Solkor-R and Solkor-Rf

Since Solkor protection is a current balance scheme, fault current intertripping can be effected by open circuiting the pilot loop. The magnitude of the current required through remote current transformers to cause operation of the relay depends somewhat on the intercore capacitance of the pilot line. For reliable intertripping the minimum fault current through the remote current transformers should not be less than twice the nominal fault setting for each type of fault.

4.2.2 DC injection intertripping

Solkor R may also be intertripped by the direct application of a 110V dc voltage source to the local end of the pilots. This d.c. may be derived from a 5kV or 15kV isolated intertripping battery or from a secure full wave rectified 110V, 50/60Hz, voltage derived from a 5kV or 15kV isolation transformer.

4.2.3 Injection intertripping - Solkor-R & Solkor-Rf

Injection intertripping is used where decisive intertripping is required, irrespective of the current in the protected feeder, and to avoid possible interaction between the injected signal and power frequency voltages. Its use also avoids the requirement for 5kV or 15kV insulated intertripping batteries.

Injection intertripping is not suitable for use with guard relays (which place normally open contacts in series with the Solkor relay contact) or for Solkor-R with Supervision applied to the same pilots, (for such schemes Supervision may be carried out over spare cores). Due to a different inverter being required, Solkor-Rf can use both injection intertripping and supervision over the same pilots.

The send equipment comprises an inverter and a type TEC relay to switch the a.c. intertripping signal, Solkor-Rf requires an additional time delay relay. The receive relay is the remote Solkor relay. It is unnecessary to continuously energise the inverter, normally a full power signal is sent for 2 secs, followed by either de-energisation of the inverter or by a reduced inverter output which holds the remote relay operated, see fig 9.

Note applicable to all schemes:-

Where contacts are directly connected to the pilot wires then 5kV/15kV isolation must be maintained from earth and other circuits.

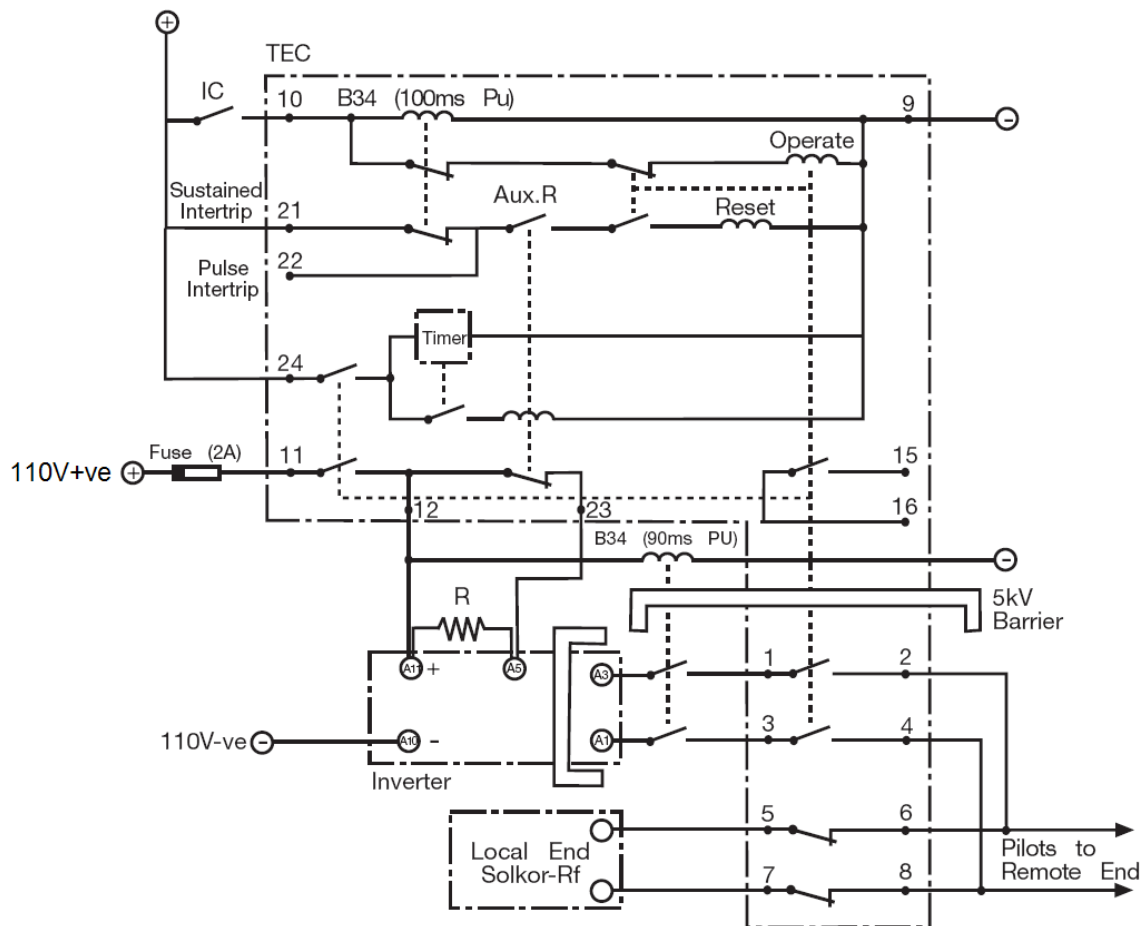

Fig. Typical 2 stage sustained intertripping scheme for Solkor –Rf. Send End.

4.3 Commissioning

This publication gives details of the tests necessary to prove that the Solkor Rf injection intertripping equipment using a type TEC relay and a D.C./ A.C. inverter has been installed and is operating correctly.

For connections of the equipment reference should be made to the appropriate schematic diagram. Tests of the Solkor Rf protection should be done separately as detailed in leaflet OR/R.

4.3.1 Description of operation of TEC relay

Operation of the intertrip send initiating contact causes the multi-contact, electrically reset type F element to operate and this immediately open circuits the pilots on the local-end relay side and connects the injection supply across the pilots. The contacts on the pilot side are insulated to withstand a voltage of 5kV or 15kV to earth.

At the same time a type B relay element is energised and after 100 milli-seconds a contact on this relay isolates the operate coil circuit of the multi-contact type F element.

After 2 seconds a type TCD timing relay which is energised from a contact on the type F element resets the type F element thus disconnecting the injection supply.

A two second intertrip pulse is therefore given irrespective of whether the initiating contact is self or hand reset. If the initiating contact is self reset the TEC relay resets completely but if it is hand reset the type B element remains energised until the Initiating contact is reset.

4.3.2 Check on D.C/ A.C. inverter

Remove external connections from inverter terminals A1, A3.

Connect a 20 watt 2000 ohm resistor across terminals A1 and A3. Arrange the test circuit as shown in Fig.10.

Measure the, input voltage and the voltage across the 2000 ohm resistor.

Check that the output voltage across the 2000 ohm resistor is within the limits shown in Fig 11.

Check that the input current does not exceed 2 amps D.C.

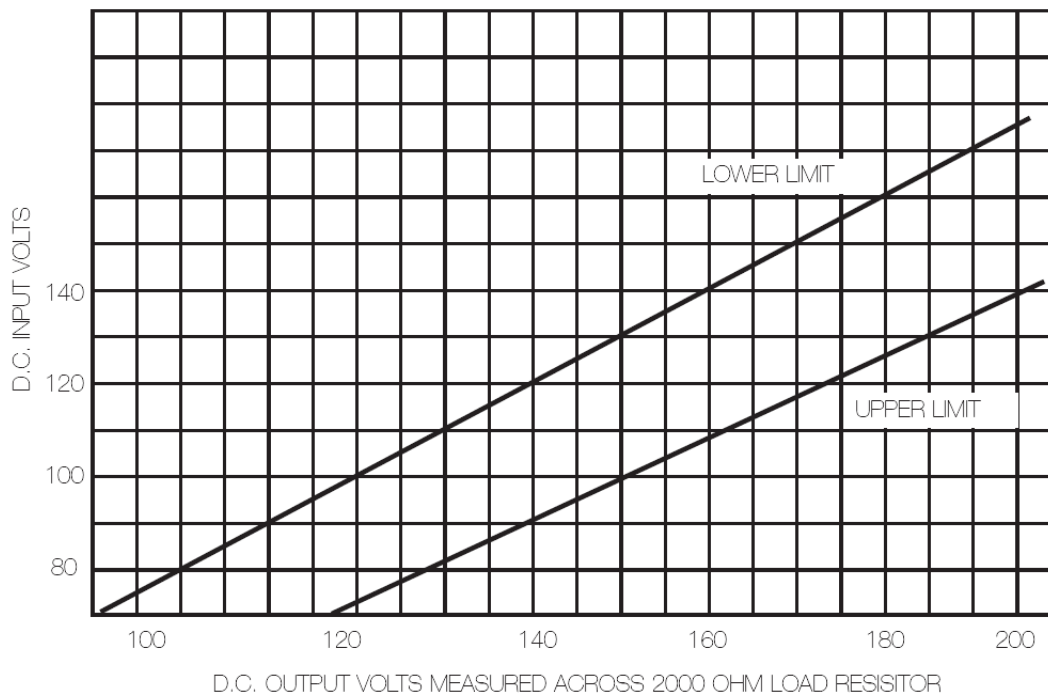

Fig. DC/AC Inverter (Art.No. 410A21535)

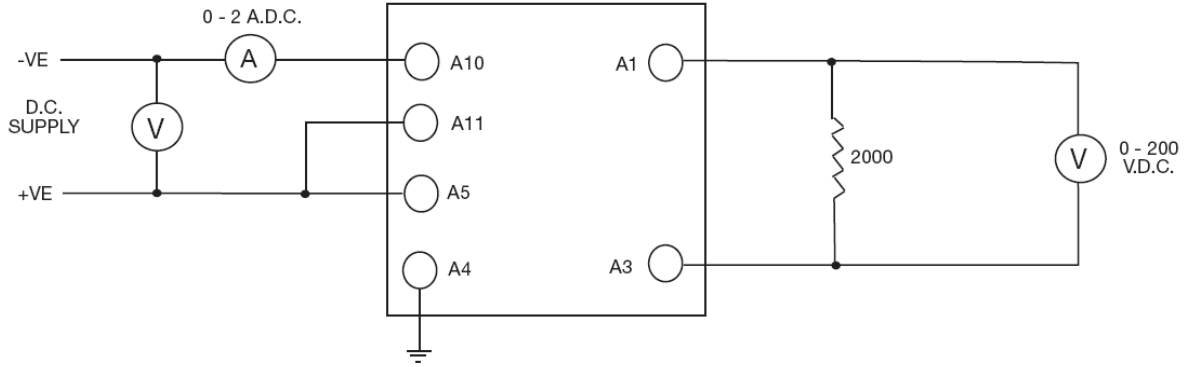

Fig. Test Circuit – Inverter

4.3.3 Putting into Service

Restore all connections to their correct terminals. Insert D.C. supply links and fuses and intertrip links.

Operate the intertrip send initiating contact at each end. Check that the remote end relay operates and that the correct alarms and indications are given.

7PG21 Solkor Rf

Feeder Protection

Document Release History

This document is issue 02/2010. The list of revisions up to and including this issue is:
Pre release

02/2010	Document reformat due to rebrand

Software Revision History

--	--	--

The copyright and other intellectual property rights in this document, and in any model or article produced from it (and including any registered or unregistered design rights) are the property of Siemens Protection Devices Limited. No part of this document shall be reproduced or modified or stored in another form, in any data retrieval system, without the permission of Siemens Protection Devices Limited, nor shall any model or article be reproduced from this document unless Siemens Protection Devices Limited consent.

While the information and guidance given in this document is believed to be correct, no liability shall be accepted for any loss or damage caused by any error or omission, whether such error or omission is the result of negligence or any other cause. Any and all such liability is disclaimed.

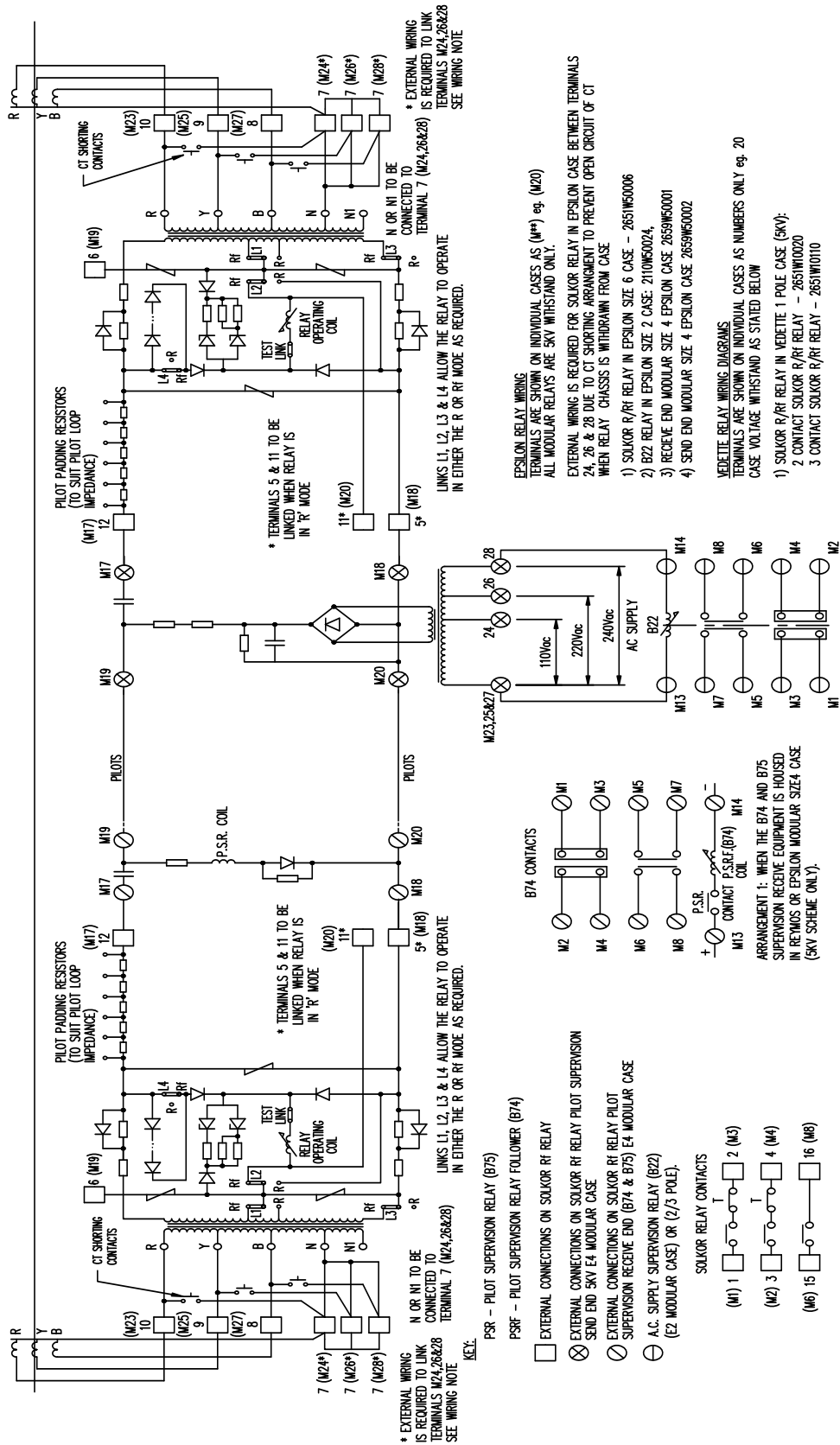

Figure 1. 5kV Solkor Rf with Pilot Supervision

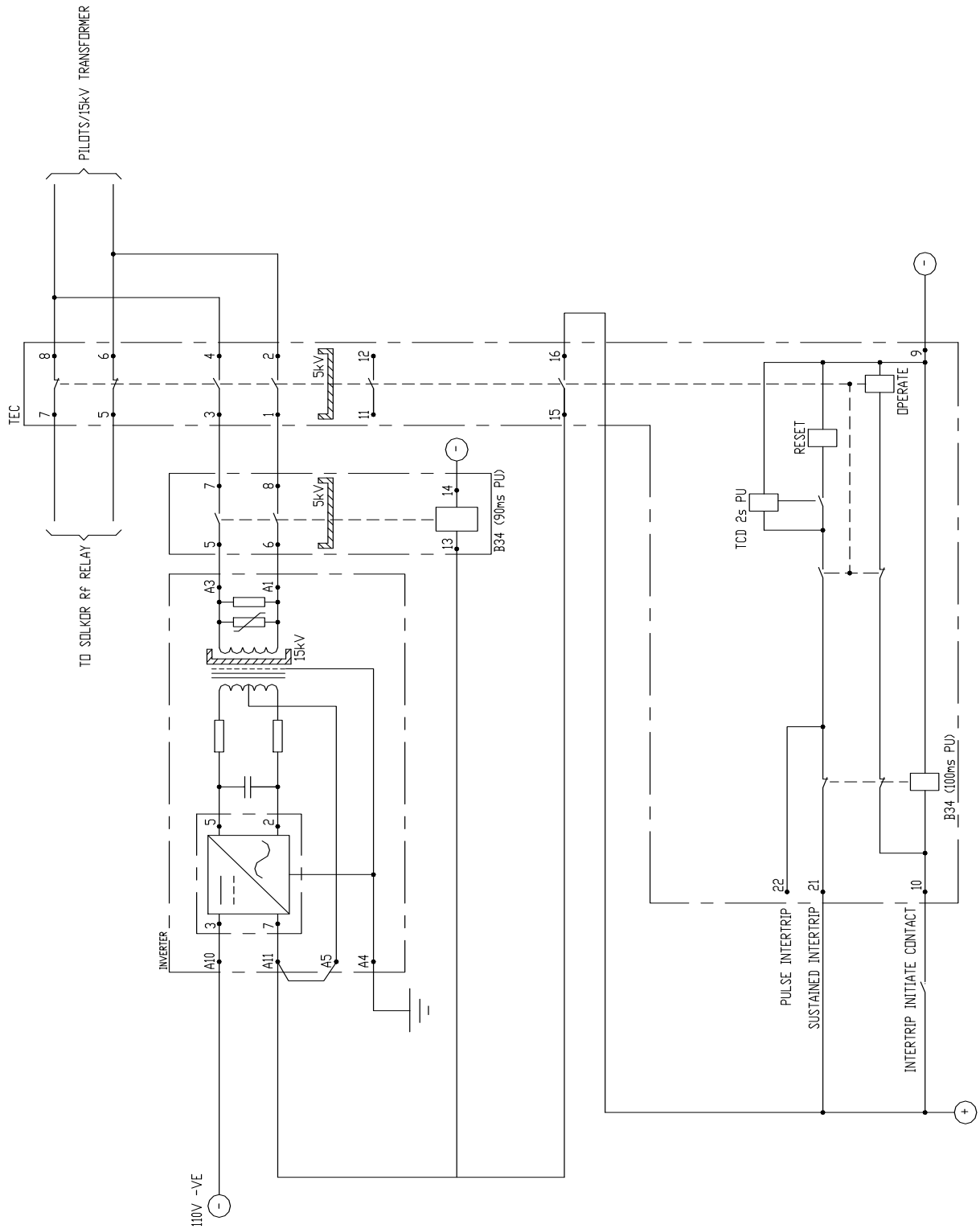

Figure 3. Solkor Rf mode Intertripping

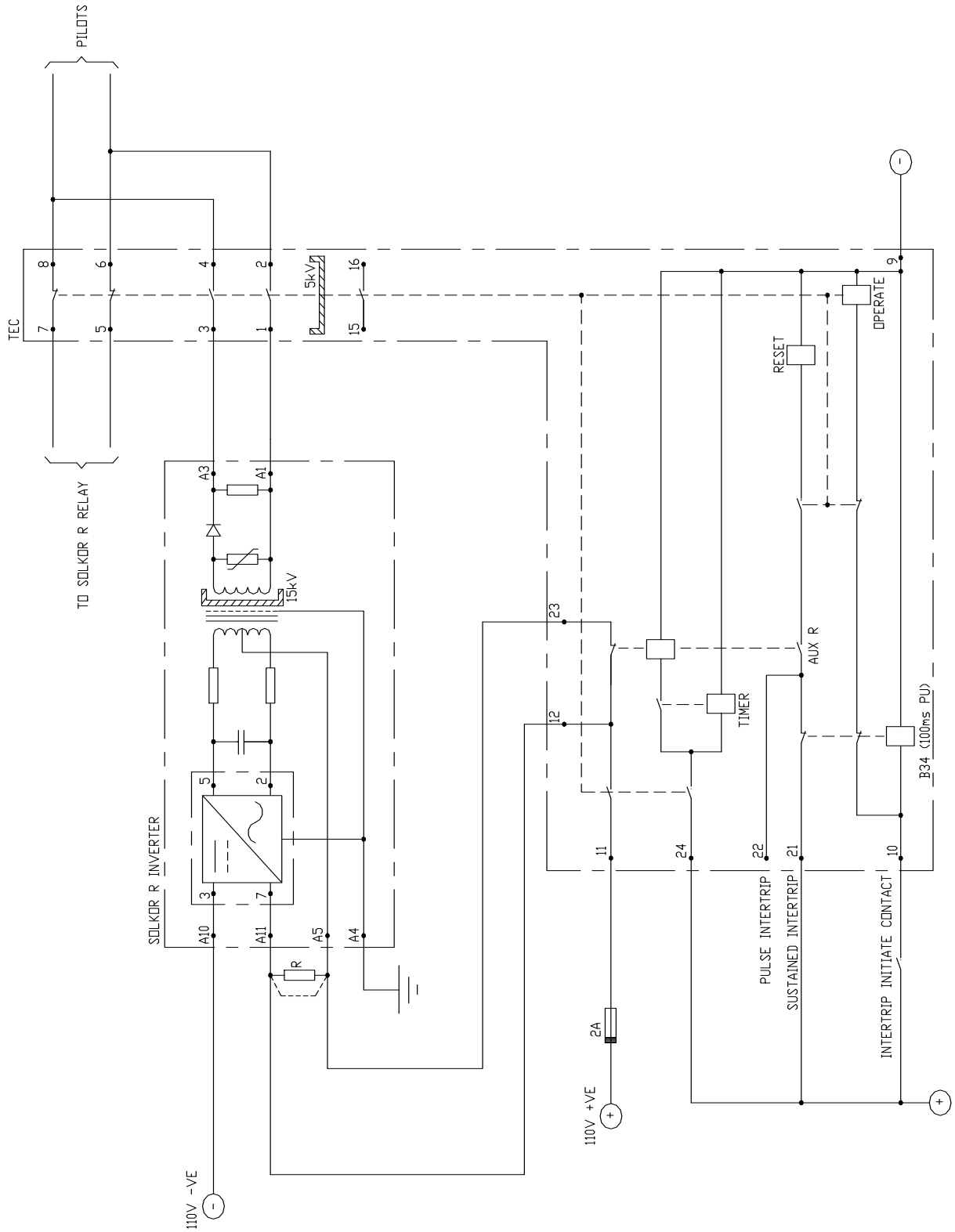

Figure 6. 5kV Solkor R mode 2 Stage Intertripping

Siemens Protection Devices Limited
P.O. Box 8
North Farm Road
Hebburn
Tyne & Wear
NE31 1TZ
United Kingdom
Phone: +44 (0)191 401 7901
Fax: +44 (0)191 401 5575
Web: www.siemens.com/energy

PTD 24h Customer Support
Phone: +49 180 524 7000
Fax: +49 180 524 2471
E-mail: support.energy@siemens.com
Data is subject to change without notification.