

# ARGUS-C

## 7SR11 and 7SR12 Overcurrent Relays

### Description

The ARGUS-C is an overcurrent protection relay developed to enhance the ARGUS family of products by providing a familiar product using the latest generation of hardware technology.

The 7SR11 overcurrent and earth fault relays and the 7SR12 directional relays are available in single and four pole variants.

Housed in 4U high, size E4 case, these relays provide protection, monitoring, instrumentation and metering with integrated input and output logic, data logging & fault reports. Communication access to relay functionality is via a front USB port for local PC connection or rear electrical RS485 port for remote connection.



### Function Overview

#### Protection

37	Undercurrent
46BC	Broken Conductor / Load Unbalance
46NPS	Negative Phase Sequence Overcurrent
49	Thermal Overload
50	Instantaneous Overcurrent
50G/N/SEF	Instantaneous Earth Fault
50BF	Circuit Breaker Fail
51	Time Delayed Overcurrent
51G/N/SEF	Time Delayed Measured/Derived/Sensitive Earth Fault
64H	High Impedance REF
27/59	Under/Over Voltage
47	Negative Phase Sequence Voltage
51V	Voltage Controlled Overcurrent
59N	Neutral Voltage Displacement
67/50	Directional Instantaneous Overcurrent
67/50G/N	Directional Instantaneous Earth Fault
67/51	Directional Time Delayed Overcurrent
67/51G/N	Directional Time Delayed Earth Fault
81HBL2	Inrush Detector

#### Supervision

60CTS	CT Supervision
74TC/CC	Trip & Close Circuit Supervision
60VTS	VT Supervision

#### Control

79	Auto Reclose
----	--------------

#### Features

Cold Load Settings  
Four Settings Groups  
Password Protection – 2 levels  
User Programmable Logic  
Self Monitoring  
Starters  
Circuit Breaker Trip and Maintenance Counter  
Trip Timers

### User Interface

20 Character x 4 Line Backlit LCD  
Menu Navigation Keys  
9 User Programmable Tri-colour LEDs  
User Language Configuration

### Monitoring Functions

Primary/Secondary Current Phases and Earth Direction  
Primary/Secondary Line and Phase Voltages  
Apparent Power and Power Factor  
Real and Reactive Power  
W Hr & VAr Hr Forward and Reverse  
Historical Demand Record  
Positive Phase Sequence (PPS) Voltage & Current  
Negative Phase Sequence (NPS) Voltage & Current  
Zero Phase Sequence (ZPS) Voltage

### Hardware

1 CT 3 Binary Inputs 5 Binary Outputs  
4 CT 3 Binary Inputs 5 Binary Outputs  
4 CT 6 Binary Inputs 8 Binary Outputs  
1 CT 3 VT 3 Binary Inputs 5 Binary Outputs  
4 CT 3 VT 3 Binary Inputs 5 Binary Outputs  
4 CT 3 VT 6 Binary Inputs 8 Binary Outputs

### Data Storage and Communication

Front USB port + Rear RS485 port  
Protocols - IEC60870-5-103, DNP3.0 or Modbus RTU  
Event Records – User Configurable  
Fault Records  
Waveform Records  
Measurands  
Commands  
Time Synchronism  
Viewing and Changing Settings

### Support Software

Reydisp Evolution

## Application

The ARGUS-C is a numerical overcurrent protection relay intended for use on distribution and industrial networks. It provides a highly comprehensive functional software package with a range of integral application functions aimed at reducing installation, wiring and engineering time.

An extensive range of metered values can be viewed on the front LCD or at a remote point via the communication channel.

The integrated control feature allows operation of a single circuit breaker and monitoring of its trip and close circuits.

## Function Matrix

FUNCTION	FUNCTIONAL REQUIREMENT	7SR1101-1* A12-*CA0	7SR1101-3* A12-*CA0	7SR1102-1* A12-*CA0	7SR1102-3* A12-*CA0	7SR1204-2* A12-*CA0	7SR1204-4* A12-*CA0	7SR1205-2* A12-*CA0	7SR1205-4* A12-*CA0
27	Undervoltage					■	■	■	■
37	Undercurrent			■	■			■	■
46BC	Broken Conductor / Load Unbalance			■	■			■	■
46NPS	Negative Phase Sequence Overcurrent			■	■			■	■
47	Negative Phase Sequence Voltage					■	■	■	■
49	Thermal Overload			■	■			■	■
50	Instantaneous Overcurrent			■	■			■	■
50G	Measured Instantaneous Earth Fault	■		■		■		■	
50SEF	Measured Instantaneous Sensitive Earth Fault		■		■		■		■
50N	Derived Instantaneous Earth Fault			■	■			■	■
50BF	CB Failure	■	■	■	■	■	■	■	■
51	Time Delayed Overcurrent			■	■			■	■
51G	Measured Time Delayed Earth Fault	■		■		■		■	
51SEF	Measured Time Delayed Sensitive Earth Fault		■		■		■		■
51N	Derived Time Delayed Earth Fault			■	■			■	■
59	Overvoltage					■	■	■	■
59N	Neutral Voltage Displacement					■	■	■	■
64H	High Impedance Restricted Earth Fault	■	■	■	■	■	■	■	■
67	Directional Overcurrent					■	■	■	■
67G	Directional Measured Earth Fault					■		■	
67SEF	Directional Sensitive Earth Fault					■	■		■
67N	Directional Derived Earth Fault						■	■	■
<b>CONTROL / MONITOR</b>									
51c	Cold Load - Phase Only			■	■			■	■
60CTS	CT Supervision			■	■			■	■
60VTS	VT Supervision					■	■	■	■
74T/CCS	Trip & Close Circuit Supervision	■	■	■	■	■	■	■	■
79	Autoreclose			□	□			□	□
86	Lockout	■	■	■	■	■	■	■	■

Key - ■ Included as standard

□ Ordering option

# Functional Diagrams

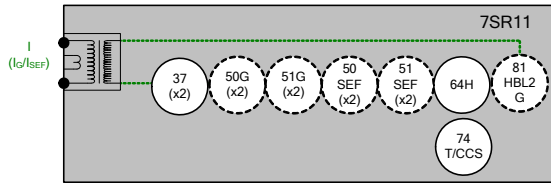

Fig. 1. Single Pole Overcurrent Relay

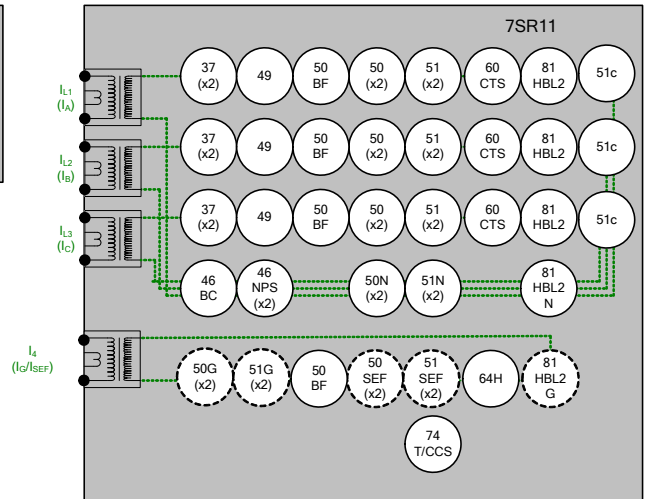

Fig. 2. Four Pole Overcurrent Relay

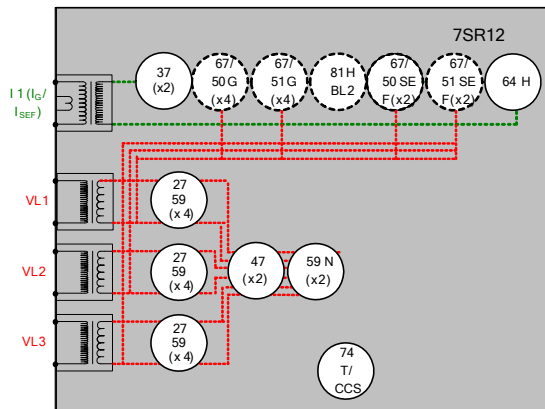

Fig. 3. Single Pole Directional Overcurrent Relay

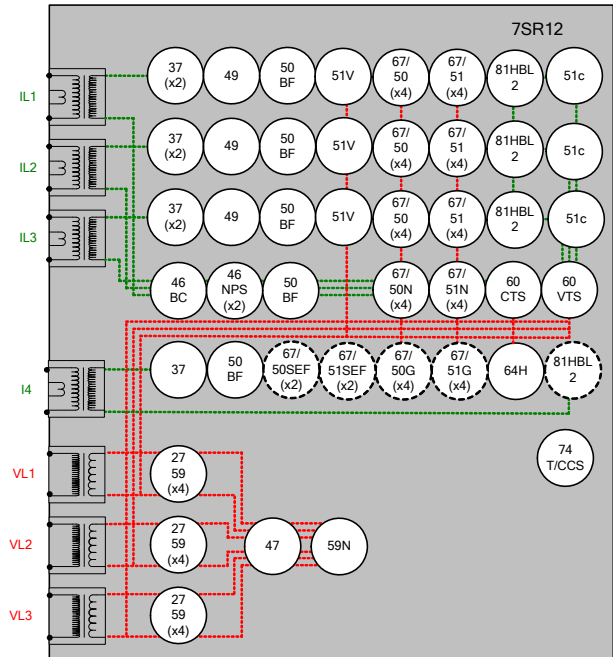

Fig. 4. Four Pole Directional Overcurrent Relay

**Notes**

1. Items shown dotted are only available in some models, please refer to the Ordering Information Section.
2. The use of some functions are mutually exclusive.

## Description of Functionality

### 27/59 Under/Over Voltage

Each element has settings for pickup level, drop-off level and Definite Time Lag (DTL) delays. Operates if voltage exceeds setting for duration of delay.

### 37 Undercurrent

Each element has settings for pickup level and Definite Time Lag (DTL) delays. Operates if current falls below setting for duration of delay.

### 46BC Phase Unbalance/Broken Conductor

Element has settings for pickup level and DTL delay. With the circuit breaker closed, if the NPS:PPS current ratio is above setting this could be due to a broken conductor.

### 46NPS Negative Phase Sequence Overcurrent

Each element has user settings for pickup level and IDMTL or DTL delay, operates if NPS current exceeds setting and delay. NPS current elements can be used to detect unbalances on the system or remote earth faults when a delta-star transformer is in circuit.

### 47 Negative Phase Sequence Voltage

Each element has settings for pickup level and Definite Time Lag (DTL) delays. Operates if NPS voltage exceeds setting for duration of delay.

### 49 Thermal Overload

The thermal algorithm calculates the thermal states from the measured currents and can be applied to lines, cables and transformers. Alarm outputs are given for thermal overload and thermal capacity.

### 50BF Circuit Breaker Fail

The circuit breaker fail function may be triggered from an internal trip signal or from a binary input. Line currents and earth currents are monitored following a trip signal and an output is issued if any current is still detected, above setting, after a specified time interval. Alternatively, if the trip is from a mechanical protection the circuit breaker position can be used to determine a failure. A second time delay is available to enable another stage to be utilized if required. An input is also available to bypass the time delays when the circuit breaker is known to be faulty.

### 50/51 Phase Fault

50 INST/DTL and 51 IDMTL/DTL elements provide overcurrent protection, each with independent settings for pickup current, time-multiplier (51) and time-delays. User can select IEC or ANSI time current characteristics. The IDMT stage has a user programmable reset characteristic, either DTL or shaped current ~ time reset characteristic, to improve grading with electromechanical protection.

### 50G/51G/50N/51N Earth Fault/Sensitive Earth Fault

Two earth fault measurement modes are available. One mode directly measures the earth current from an independent CT, or the residual connection of the 3 line CTs. This input can be ordered as either earth fault or sensitive earth fault (50G/51G).

The second mode derives the earth current internally from the 3 phase CT inputs to give earth fault (50N/51N). 50 INST/DTL and 51 IDMTL/DTL elements provide overcurrent protection, each with independent settings for pickup current, time-multiplier (51) and time-delays. User can select IEC or ANSI time current characteristics. The IDMT stage has a user programmable reset characteristic either DTL or shaped current ~ time reset characteristic to improve grading with electromechanical protection.

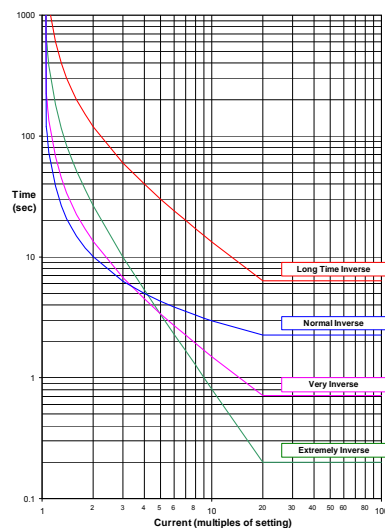

Fig. 5. IEC Overcurrent Curves

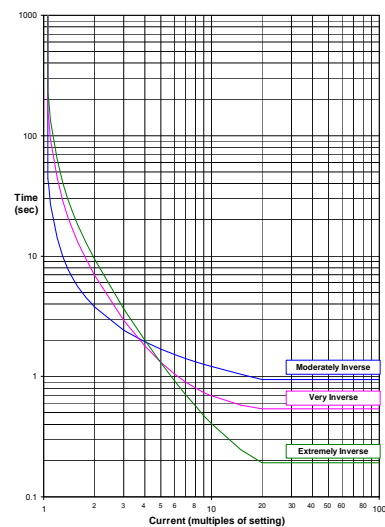

Fig. 6. ANSI Overcurrent Curves

### 51V Voltage Controlled Overcurrent

Each phase shaped overcurrent element can be independently controlled by the level of measured input voltage. For applied voltages above setting the 51-n element operates in accordance with its current setting but for voltages below the setting a multiplier is applied to reduce the 51-n pick up current setting.

### 59N Neutral Overvoltage

Neutral overvoltage can be used to detect earth faults in high impedance earthed or isolated systems. Operates if the neutral voltage exceeds setting for duration of delay.

### 60CTS CT Supervision

The relay has two methods of CT supervision depending upon the relay model. The 7SR11 monitors each phase current input and operates if any one or two inputs fall below the setting. The 7SR12 considers the presence of negative phase sequence current, without an equivalent level of negative phase sequence voltage, for a user set time as a CT failure.

Both element types have user operate and delay settings.

### 60VTS VT Supervision

The VT supervision uses a combination of negative phase sequence voltage and negative phase sequence current to detect a VT fuse failure. This condition may be alarmed or used to inhibit voltage dependent functions. Element has user operate and delay settings.

### 64H Restricted Earth Fault

The measured earth fault input may be used in a 64H high impedance restricted earth fault scheme to provide sensitive high speed unit protection. A calculation is required to determine the values of the external series stabilising resistor and non-linear shunt resistor which can be ordered separately.

### 67/67N Directional Control

Phase, earth and sensitive earth fault elements can be directionalised. Each element can be user set to Forward, Reverse, or Non-directional.

Directional Phase Fault elements are polarised from quadrature voltage.

Derived earth fault elements can be user set to be polarised from residual voltage or negative phase sequence voltage.

Measured earth fault elements are polarized from  $V_0$ .

### 74T/C Trip & Close Circuit Supervision

The trip or close circuit(s) can be monitored via binary inputs. Trip circuit failure raises an HMI alarm and output(s).

### 81HBL2 Inrush Restraint

Where second harmonic current is detected (i.e. during transformer energisation) user selectable elements can be blocked and an alarm given.

### 51c Cold Load Pickup

If a circuit breaker is closed onto a 'cold' load, i.e. one that has not been powered for a prolonged period, this can impose a higher than normal load-current demand on the system which could exceed normal settings. These conditions can exist for an extended period and must not be interpreted as a fault. To allow optimum setting levels to be applied for normal operation, the cold load pickup feature will apply alternative current settings for a limited period. The feature resets when either the circuit breaker has been closed for a settable period, or if the current has reduced beneath a set level for a user set period.

### Standard Version – Plus 79 Auto-Reclose

A high proportion of faults on an overhead line network are transient and can be cleared quickly by high speed tripping followed by an automated circuit breaker reclose sequence.

The function provides independent phase fault and earth fault / sensitive earth fault sequences of up to 5 trip i.e. 4 reclose attempts before lockout. An auto-reclose sequence can be user set to be initiated from internal protection operation or via binary input from an external protection.

### Programmable Logic

The user can map binary inputs, protection elements, LEDs and binary outputs together in a logical scheme.

Up to 4 logic equations can be defined using standard logic functions e.g. Timers, AND/OR gates, Inverters and Counters to provide the user required functionality.

Each logic equation output can be used for alarm & indication and/or tripping.

### Virtual Inputs/Outputs

There are 8 virtual inputs/outputs to provide internal logical states to assist in the application of the functions. Each virtual I/O can be assigned in the same way as a physical I/O.

### Circuit Breaker Maintenance

Two circuit breaker operations counters are provided to assist with maintenance scheduling. The maintenance counter records the overall number of operations and the delta counter records the number of operations since the last reset.

An I<sup>2</sup>t summation counter provides a measure of the contact wear indicating the total energy interrupted by the circuit breaker contacts.

Each counter has a user set target operations count which, when reached, can be mapped to raise alarms/ binary outputs. A CB Trip Time meter is also available, which measures the time between the trip being issued and the auxiliary contacts changing state.

### Control Mode

The relay has a control menu with access to commonly used command operations. Access to the control commands is restricted by a 4 character control function password. Each command requires a select then execute operation, if the execute operation is not performed within a time window the command is aborted. The following control functions are available:

CB Operation

Auto Reclose In/Out

Auto Reclose Trip & Reclose

Auto Reclose Trip & Lockout

SEF In/Out

Inst Prot In/Out

Hot Line Working In/Out

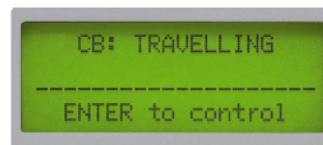

Fig. 7. Example of Control Function View

## Data Acquisition – via communication interface

### Sequence of event records

Up to 1000 events are stored and time tagged to 1ms resolution.

### Fault Records

The last 10 fault records are displayed on the relay fascia and are also available through the communication interface, with time and date of trip, measured quantities and type of fault.

### Waveform recorder

The waveform recorder stores analogue data for all poles and the states of protection functions, binary inputs, LEDs and binary outputs with user settable pre & post trigger data. A record can be triggered from protection function, binary input or via data communications. 10 records of 1 second duration are stored.

### Demand Metering

A rolling record of demand over the last 24h is stored. The demand is averaged over a user selectable period of time. A rolling record of such demand averages is stored and provides the demand history. A typical application is to record 15min averages for the last 7 days.

### Real Time Clock

The time and date can be set and are maintained while the relay is de-energised by a back up storage capacitor. The time can be synchronized from a binary input pulse or the data communication channel.

## Serial Communications

The relay offers a USB serial port as standard on the front of all units. All of the relays functions can be set on a PC using Reydisp Evolution via the USB port. The connection is made with a USB cable and operates with a 'plug and play' connection, so no pre-setting of the relay is required. The front port can be switched off or set to use either the DNP3.0, MODBUS-RTU, IEC60870-5-103 and ASCII protocols for testing purposes.

A rear RS485 electrical connection is available on all units for system interface connections. An internal terminating resistor is provided, which can be connected into the circuit by adding a wire loop between the relevant terminals.

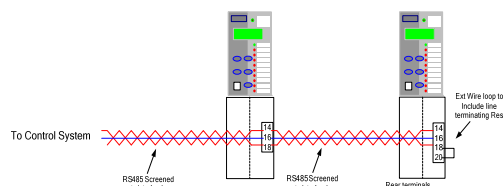

Fig. 8. Typical RS485 connection

The rear RS485 can be user selected to be Off or use the IEC60870-5-103, MODBUS RTU or DNP3.0 protocol.

## Reydisp Evolution

Reydisp Evolution is a Windows based software tool, providing the means for the user to apply settings, interrogate settings and retrieve events and disturbance waveforms from the ARGUS-C and is common to the entire range of Reyrolle protection relays.



Fig. 9. Typical Reydisp Evolution Screenshot

A language editor feature allows the user to change the text descriptions displayed in the relays menu structure and instrumentation views.

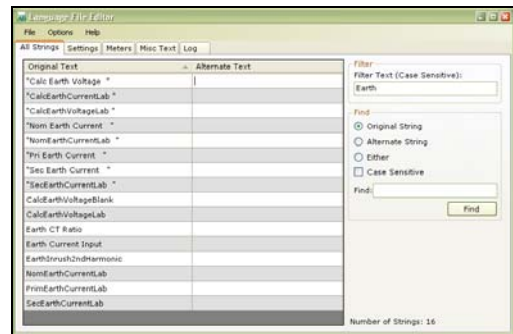

Fig. 10. Typical Language Editor Screenshot

The standard protocol mapping provided within the IEC60870-5-103, DNP3.0 and MODBUS protocols can be modified using the protocol editor to match those of the SCADA system to which it is to be connected.

## Construction

The relay is housed in a 4U high size E4 case with a removable clear plastic fascia cover. The plastic fascia cover can be ordered with or without two push buttons, to allow the user to view the settings and instruments without removing the cover.

Two plastic handles are provided to allow the relay to be withdrawn from its case, contacts in the case ensure that the CT circuits and normally closed contacts remain short circuited when the relay is withdrawn.



Fig. 11. Relay with element withdrawn

The rear terminal blocks comprise M4 female terminals for ring crimp wire connections, to provide a secure and reliable termination.

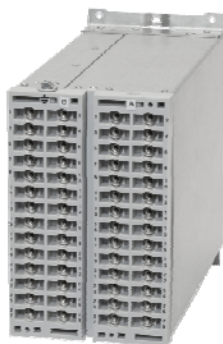

Fig. 12. Rear view of relay

## User Interface

The operator interface is designed to provide a user friendly method of controlling, viewing menus, entering settings and retrieving data from the relay. Five buttons are provided for navigation around the menu structure.

### LCD

A 4 line by 20 character liquid crystal display with power save operation indicates the relay identifier, settings, instrumentation, fault data and control commands.

Up to 6 user programmable general alarms can be configured to display your own indications on the LCD.

### LEDs

A green steadily illuminated LED indicates the 'Protection Healthy' condition.

9 user programmable LEDs are available eliminating the need for expensive panel mounted pilot lights and associated wiring. Each LED is tri-colour (red, green, yellow) allowing for clear indication of the associated function's state and has a label insert for identification.

## Relay Information

The device is identified by the rating label on the fascia. The user can also give the device its own identity by editing the 'Relay Identifier' displayed on the LCD or space is provided to place a slip in label giving the relays function.

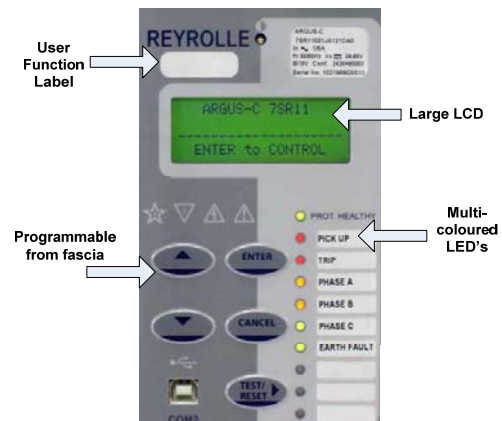

Fig. 13. User Interface

## Technical Data

For full technical data refer to the Performance Specification Section of the Technical Manual

### Input Circuits

#### Current Inputs

Quantity	3 x Phase & 1 x Earth or Sensitive Earth
Rated Current I <sub>N</sub>	1/5A
Measuring Range	80 x I <sub>N</sub>
Instrumentation $\geq 0.1 \times I_N$	$\pm 1\%$ I <sub>N</sub>
Frequency	50/60Hz
Thermal Withstand	
Continuous	3 x I <sub>N</sub>
10 Minutes	3.5 x I <sub>N</sub>
2 Minutes	6 x I <sub>N</sub>
1 Second	100A (1A) 350A (5A)
1 Cycle	700A (1A) 2500A (5A)
Burden @ I <sub>N</sub>	0.1VA (1A phase and Earth element) 0.3VA (5A phase and earth element)

#### Voltage Inputs

Quantity	3 ph-ph
Nominal Voltage	40...160V a.c. Range
Instrumentation $\geq 0.8 \times V_N$	$\pm 1\%$ V <sub>N</sub>
Thermal Withstand	
Continuous	300V
1 Second	
Burden @ 110V	$\leq 0.06$ VA

#### Auxiliary Supply

Rated DC Voltage	110/125/220/250V Range 64 to 320 24/48/60V Range 16 to 80
Power Consumption	
Min	
Max	
Allowable superimposed ac component	12% of DC voltage
Allowable breaks/dips in supply (collapse to zero)	20ms

#### Binary Inputs

Number	3 or 6
Operating Voltage	19V dc Range 17 to 290V dc 88V Range 74 to 290V dc
Minimum dc current for operation	$\leq 1.5$ mA
Pick Up Delay	User Selectable 0 to 14,400,00ms

### Binary Outputs

Number	5 or 8 (3 change over contacts)
Operating Voltage	Voltage Free
Operating Mode	User selectable - Self or Hand/Electrical Reset or pulsed.
Operating Time from Energizing Binary Input	Typically 18ms
Making Capacity	
Carry continuously	5A ac or dc
Make and carry s (L/R $\leq 40$ ms and V $\leq 300$ V)	20A ac or dc for 0.5s 30A ac or dc for 0.2s
Breaking Capacity ( $\leq 5$ A and $\leq 300$ V)	
AC Resistive	1250 VA
AC Inductive	250 VA at p.f. $\leq 0.4$
DC Resistive	75 W
DC Inductive	30 W at L/R $\leq 40$ ms 50 W at L/R $\leq 10$ ms

### Unit Design

Housing	E4 (see dimension drawing)
Indication	20 Character 4 line Display Relay Healthy LED 9 Tri Coloured User Programmable Self or Hand Reset LED's
With-drawable Element	Yes
User Interface	5 Navigation Keys
Weight	Typical 3.1Kg
IP Rating Installed with cover	IP 50
IP Rating Installed with cover removed	IP 30

### Serial Interface

Communication Port	Front USB Type B Rear RS485 2 wire electrical
Protocols	IEC60870-5-103 MODBUS RTU DNP3.0

### Data Storage

Fault Record	10
Waveform Record	10 x 1sec 1x10sec Pre trigger 10...90%
Events	5000 1ms Resolution

## Mechanical Tests

### Vibration (Sinusoidal) IEC 60255-21-1 Class I

Type	Level	Variation
Vibration response	0.5 gn	≤ 5 %
	1.0 gn	≤ 5 %

### Shock and Bump IEC 60255-21-2 Class I

Type	Level	Variation
Shock response	5 gn, 11 ms	≤ 5 %
Shock withstand	15 gn, 11 ms	≤ 5 %
Bump test	10 gn, 16 ms	≤ 5 %

### Seismic IEC 60255-21-3 Class I Mechanical Classification

Type	Level	Variation
Seismic response	1 gn	≤ 5 %

### Mechanical Classification

Durability	> 10 <sup>6</sup> operations
------------	------------------------------

## Electrical Tests

### Insulation IEC 60255-5

Type	Level
Between any terminal and earth	2.0 kV AC RMS for 1 min
Between independent circuits	2.0 kV AC RMS for 1 min
Across normally open contacts	1.0 kV AC RMS for 1 min

### High Frequency Disturbance IEC 60255-22-1 Class III

Type	Level	Variation
Common (longitudinal)	2.5 kV	≤ 5 %
Series (transverse) mode	1.0 kV	≤ 5 %

### Electrostatic Discharge IEC 60255-22-2 Class IV

Type	Level	Variation
Contact discharge	8.0 kV	≤ 5 %

### Fast Transients IEC 60255-22-4 Class IV

Type	Level	Variation
5/50 ns 2.5 kHz repetitive	4kV	≤ 5 %

### Surge Immunity IEC 60255-22-5

Type	Level	Variation
Between all terminals and earth	4.0 kV	≤ 10 %
Between any two independent circuits	2.0kV	≤ 10 %

### Conducted Radio Frequency Interference IEC 60255-22-6

Type	Level	Variation
0.15 to 80 MHz	10 V	≤ 5 %

## Emissions

### IEC 60255-25 Radiated Radio Frequency

Type	Limits at 10 m, Quasi-peak
30 to 230 MHz	40 dB(μV)
230 to 10000 MHz	47 dB(μV)

### Conducted Radio Frequency

Type	Limits	
	Quasi-peak	Average
0.15 to 0.5 MHz	79 dB(μV)	66 dB(μV)
0.5 to 30 MHz	73 dB(μV)	60 dB(μV)

### Radiated Immunity IEC 60255-22-3 Class III

Type	Level	Variation
80 MHz to 1000 MHz	10 V/m	≤ 5 %

## Climatic Tests

### Temperature IEC 60068-2-1/2

Operating Range	-10 °C to +55 °C
Storage range	-25 °C to +70 °C

### Humidity IEC 60068-2-3

Operational test	56 days at 40 °C and 95 % relative humidity
------------------	---

## Performance

### 27/59 Under/Over Voltage

Number of Elements	4 Under or Over
Operate	Any phase or All phases
Voltage Guard	1,1.5...200V
Setting Range Vs	5,5.5...200V
Hysteresis Setting	0.0.1...80%
Vs Operate Level	100% Vs, ±1% or ±0.25V
Reset Level: Undervoltage	$= (100\% - \text{hyst}) \times V_{op}$ , ±1%
Overvoltage	$= (100\% + \text{hyst}) \times V_{op}$ , ±1%
Delay Setting td	0.00,0.01...20,20.5...100,101...1000,1010...10000,10100...14400s
Basic Operate Time	
0 to 1.1xVs	73ms ±10ms
0 to 2.0xVs	63ms ±10ms
1.1 to 0.5xVs	58ms ±10ms
Operate time following delay.	Tbasic +td, ±1% or ±10ms
Inhibited by	Binary or Virtual Input VT Supervision Voltage Guard

### 37 Undercurrent

Number of Elements	2
Setting Range Is	0.05,0.10...5.0 x In
Operate Level	100% Is, ±5% or ±1% xIn
Delay Setting td	0.00,0.01...20,20.5...100,101...1000,1010...10000,10100...14400s
Basic Operate Time 1.1 to 0.5xIn	35ms ±10ms
Operate time following delay.	Tbasic +td, ±1% or ±10ms
Overshoot Time	< 40ms
Inhibited by	Binary or Virtual Input

### 46 Negative Phase Sequence Overcurrent

Number of Elements	DT & IT
DT Setting Range Is	0.05,0.10...5.0 x In
DT Operate Level	100% Is, ±5% or ±1% xIn
DT Delay Setting td	0.00,0.01...20,20.5...100,101...1000,1010...10000,10100...14400s
DT Basic Operate Time 1.1 to 0.5xIn	35ms ±10ms
DT Operate time following delay.	Tbasic +td, ±1% or ±10ms
IT Char Setting	IEC NI,VI,EI,LTI ANSI MI,VI,EI & DTL
IT Setting Range	0.05..2.5
Tm Time Multiplier	0.025,0.050...1.6
Char Operate Level	105% Is, ±4% or ±1%In
Overshoot Time	< 40ms
Inhibited by	Binary or Virtual Input

### 47 Negative Phase Sequence

Number of Elements	2
Setting Range Vs	1,1.5...90V
Hysteresis Setting	0,0.1...80%
Operate Level	100% Vs, ±2% or ±0.5V
Delay Setting td	0.00,0.01...20,20.5...100,101...1000,1010...10000,10100...14400s
Basic Operate Time	
0V to 1.5xVs	80ms ±20ms
0V to 10xVs	55ms ±20ms
Operate time following delay.	Tbasic +td, ±2% or ±20ms
Overshoot Time	< 40ms
Inhibited by	Binary or Virtual Input

### 49 Thermal Overload

Operate levels	Operate and Alarm
Setting Range Is	0.10,0.11...3.0 x In
Operate Level	100% Is, ±5% or ±1% xIn
Time Constant Setting	1,1.5...1000min
Operate time	$t = \tau \times \ln \left\{ \frac{I^2 \cdot I_p^2}{I^2 \cdot (k \times I_B)^2} \right\}$ , ±5% absolute or ±100ms where Ip = prior current
Alarm Level	Disabled, 50,51...100%
Inhibited by	Binary or Virtual Input

### 50 (67) Instantaneous & DTL OC&EF (Directional)

Operation – 7SR12 only	Non directional, Forward or reverse
Elements	Phase, Derived Earth and Measured Earth
Number of Elements	2/4 x OC 2 x 7SR11 4 x 7SR12
	2/4 x Derived EF 'N' 2/4 x Measured EF 'G' where fitted 2/4 x SEF where fitted
Setting Range Is	0.10,0.11...2.5 x In SEF 0.005...5 x In
Operation – 7SR12 only	Non directional, Forward or reverse
Time Delay	0.00...14400s
Operate Level	100% Is, ±5% or ±1% xIn
Operate time - 50	0 to 2xIs – 35ms, ±10ms, 0 to 5xIs – 25ms, ±10ms
50N	0 to 2xIs – 40ms, ±10ms, 0 to 5xIs – 30ms, ±10ms
Operate time following delay	Tbasic +td, ±1% or ±10ms
Inhibited by	Binary or Virtual Input Inrush detector VT Supervision

### 51(67) Time Delayed OC&EF (Directional)

Operation – 7SR12 only	Non directional, Forward or reverse
Elements	Phase, Derived Earth, Measured Earth & SEF
Number of Elements 2 x 7SR11 4 x 7SR12	2/4 x OC 2/4 x Derived EF 'N' 2/4 x Measured EF 'G' 2/4 x SEF where fitted
Operation – 7SR12 only	Non directional, Forward or reverse
Characteristic	IEC NI,VI,EI,LTl ANSI MI,VI,EI & DTL
Setting Range Is	0.05,0.1...2.5 x In SEF 0.005...1 x In
Time Multiplier	0.025,0.05...1.6
Time Delay	0,0.01... 20s
Operate Level	105% Is, ±4% or ±1%xIn
Minimum Operate time IEC	$t_{op} = \frac{K}{\left[\frac{I}{I_s}\right]^\alpha - 1} \times Tm,$
ANSI	$t_{op} = \left[ \frac{A}{\left[\frac{I}{I_s}\right]^p - 1} + B \right] \times Tm$ ± 5 % absolute or ± 30 ms
Follower Delay	0 - 20s
Reset	Ansi decaying, 0 – 60s
Inhibited by	Binary or Virtual Input Inrush detector VT Supervision

### 51V Voltage Controlled Overcurrent

Setting Range	5,5.5...200V
Operate Level	100% Vs, ±5% or ±1%xVn
Multiplier	0.25.0.3...1 x 51Is
Inhibited by	VT Supervision

### 50BF Circuit Breaker Fail

Operation	Current check - Phase and Measured Earth with independent settings Mechanical Trip CB Faulty Monitor
Setting Range Is	0.05,0.055...2.0 x In
2 Stage Time Delays	Timer 1 0,5...60000ms Timer 2 0,5...60000ms
Operate Level	100% Is, ±5% or ±1%xIn
Basic Operate time	<20ms
Operate time following delay	Tdelay ±1% or ±10ms
Triggered by	Any function mapped as trip contact.
Inhibited by	Binary/Virtual Input
Timer By pass	Yes, 50BF CB Faulty Input

### 59N Neutral Voltage Displacement

Number of Elements	DT & IT
DT Setting Range Is	1...100V

DT Operate Level	100% Vs, ±5% or ±1%xVn
DT Delay Setting td	0 ...14400s
DT Basic Operate Time 0V to 1.5xVs	76ms ±20ms
DT Operate time following delay.	Tbasic +td, ±1% or ±20ms
IT Char Setting	IEC NI,VI,EI,LTl ANSI MI,VI,EI & DTL
IT Setting Range	1...100V
Tm Time Multiplier(IDMT)	0.1...140
Delay (DTL)	0...20s
Reset	ANSI Decaying...60s
Char Operate Level	105% Vs, ±4% or ±1%Vn
Inhibited by	Binary or Virtual Input

### 60 Supervision

CT	7SR11 Current 7SR12 Vnps & Inps
VT	nps/zps

### 64H Restricted Earth Fault

Setting Range	0.05...0.95xIn
Operate Level	100% Is, ±5% or ±1%xIn
Time Delay	0.00... 14400s
Basic Operate Time	0 to 2 xls 45ms ±10ms 0 to 5 xls 35ms ±10ms
Inhibited by	Binary or Virtual Input

### 74T/CC Trip/Close Circuit Supervision

Number of supervisable circuits	3 x Trip and 3 x Close
Number of BI's Required	1 or 2 per function

### 79 AutoReclose

Operating Mode	Phase, Earth, SEF External
Number of Reclosures	4
Number of Trips	5
Dead Time	0...14400
Reclaim Time	0...600
Lockout Reset	CB, Timer & BI

### Control Functions

CB	Open/Close
Inst Prot	IN/OUT
EF	IN/OUT
SEF	IN/OUT
Hot Line	IN/OUT
Relay Mode	Local/Remote/Local or Remote
Reset	LED's & O/P's

### CB Maintenance

Trip Counter	Total & Delta 0...10000
Counts to AR Block	0...10000
Frequent Operations	0...10000
I^2t Alarm	10...100000

## E4 Case Dimensions

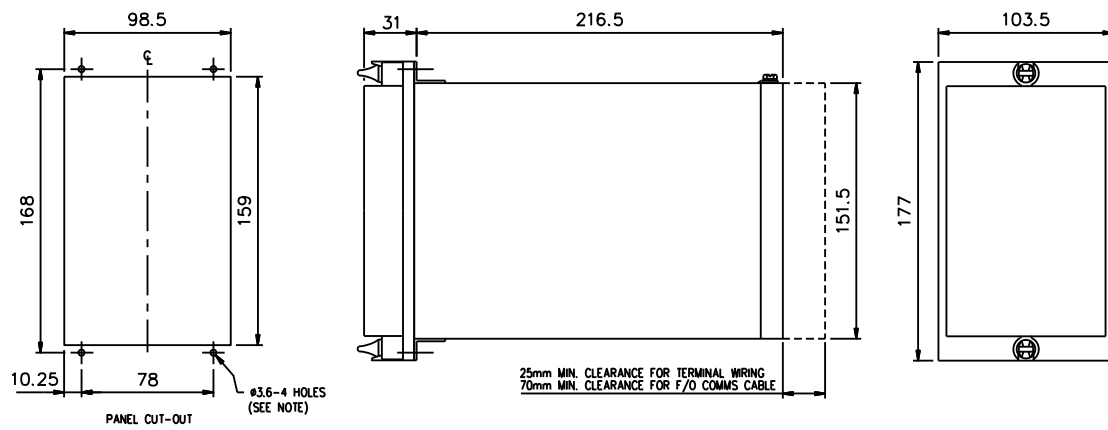

NOTE:  
 THE #3.6 HOLES ARE FOR M4 THREAD FORMING (TRILOBULAR) SCREWS. THESE ARE SUPPLIED AS STANDARD AND ARE SUITABLE FOR USE IN FERROUS/ALUMINIUM PANELS 1.6mm THICK AND ABOVE. FOR OTHER PANELS, HOLES TO BE M4 CLEARANCE (TYPICALLY #4.5) AND RELAYS MOUNTED USING M4 MACHINE SCREWS, NUTS AND LOCKWASHERS (SUPPLIED IN PANEL FIXING KIT).

Fig. 14. Relay Dimensions

## Connection Diagrams – ARGUS-C

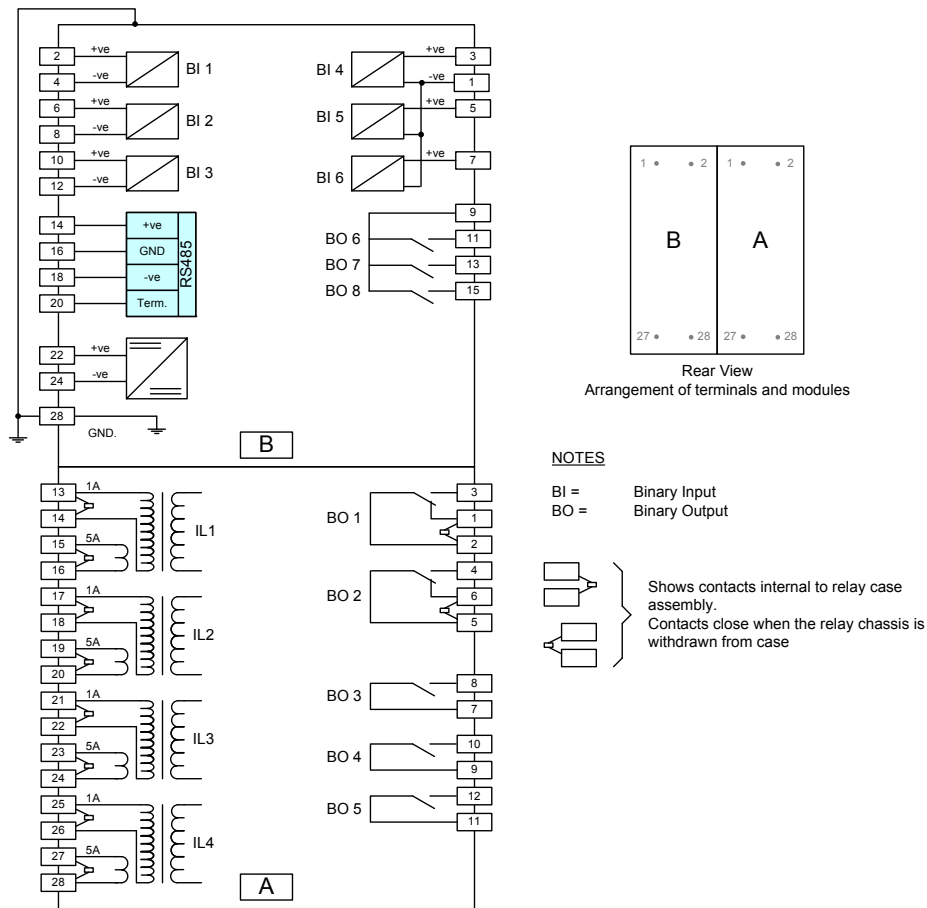

Fig. 15. Diagram showing 7SR11 relay with 4 CT inputs with 6 binary inputs and 8 binary outputs.

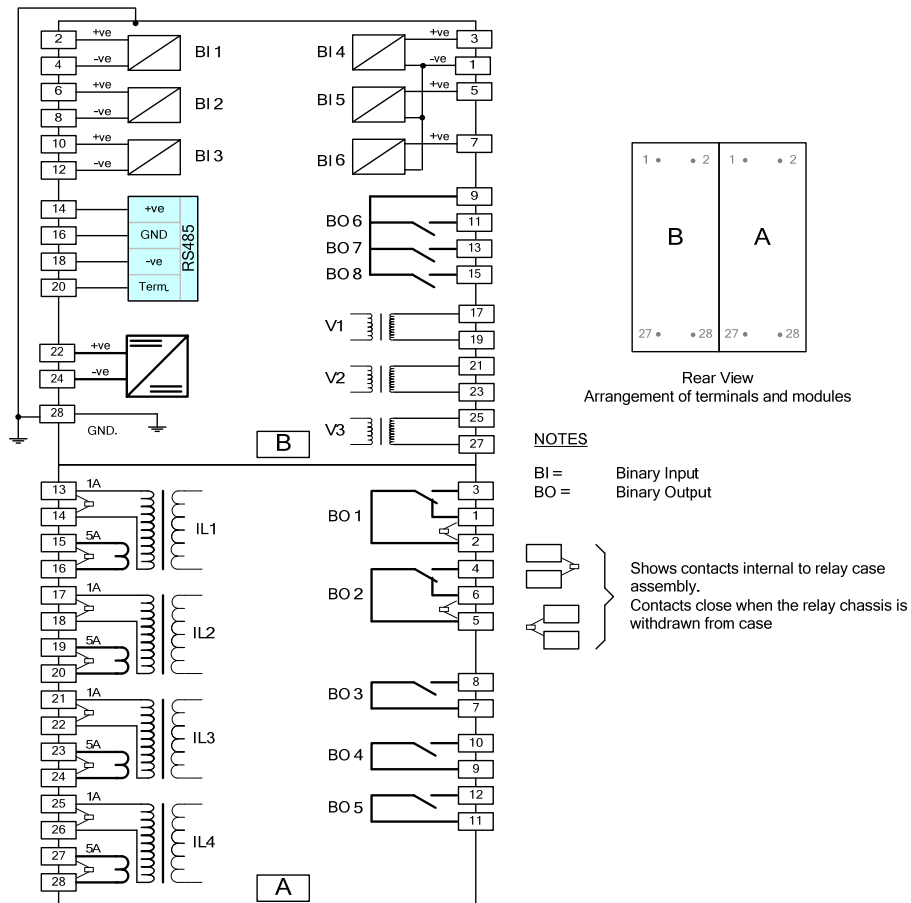

Fig. 16. Diagram showing 7SR12 relay with 4 CT inputs, 3 VT inputs with 6 binary inputs and 8 binary outputs.

# Ordering Information – ARGUS-C 7SR11 Non-Directional Overcurrent

Product description	Variants	Order No.
<b>Nondirectional O/C Relay</b>		<b>7 S R 1 1 0 □ - □ □ A 1 2 - □ □ A 0</b>
Compact overcurrent and earth fault protection relay		
<u>Protection Product</u> Overcurrent – Non Directional		1
<u>Case I/O and Fascia</u> E4 case, 1 CT, 3 Binary Inputs / 5 Binary Outputs, 10 LEDs E4 case, 4 CT, 3 Binary Inputs / 5 Binary Outputs, 10 LEDs E4 case, 4 CT, 6 Binary Inputs / 8 Binary Outputs, 10 LEDs		1 2 3
<u>Measuring Input</u> 1/5 A, 50/60Hz <sup>1)</sup> 1/5 A, 50/60Hz with SEF Input <sup>2)</sup>		1 3
<u>Auxiliary voltage</u> 80 to 250V DC, binary input threshold 19V DC 80 to 250V DC, binary input threshold 88V DC 24 to 60V DC, binary input threshold 19V DC		G H J
<u>Communication Interface</u> Standard version – included in all models, USB front port, RS485 rear port		1
<u>Protocol</u> IEC 60870-5-103 and Modbus RTU and DNP3 (user selectable setting)		2
<u>Relay Cover</u> Standard Version – No Push Buttons Push Buttons – Down and Right Arrows		1 2
<u>Protection Function Packages</u> Standard version – Included in all models		C
37 Undercurrent		
46BC <sup>3)</sup> Broken conductor/load unbalance		
46NPS <sup>3)</sup> Negative phase sequence overcurrent		
49 <sup>3)</sup> Thermal overload		
50 <sup>3)</sup> Instantaneous phase fault overcurrent		
50BF <sup>3)</sup> Circuit breaker fail		
50G/50N Instantaneous earth fault		
50SEF <sup>2)</sup> Instantaneous sensitive earth fault		
51 <sup>3)</sup> Time delayed phase fault overcurrent		
51G/51N Time delayed earth fault/SEF		
51SEF <sup>2)</sup> Time delayed sensitive earth fault		
60CTS <sup>3)</sup> CT Supervision		
64H High Impedance REF		
74T/CC Trip & Close circuit supervision		
81HBL <sup>2)</sup> 2 <sup>nd</sup> Harmonic Block/Inrush Restraint		
51c <sup>3)</sup> Cold load pickup Programmable logic		
Standard version – plus 79 Autoreclose		D
<u>Additional Functionality</u> No Additional Functionality		A

<sup>1)</sup>4CT is configured as 3PF + EF .

<sup>2)</sup> 4CT is configured as 3PF + SEF/REF

<sup>3)</sup> Functions only available in 4CT relay

<sup>4)</sup> Not available in SEF model

## Ordering Information – ARGUS-C 7SR12 Directional Overcurrent

Product description	Variants	Order No.
<b>Directional O/C Relay</b>		<b>7 S R 1 2 0 □ - □ □ A 1 2 - □ □ A 0</b>
Compact directional Overcurrent and earth Fault Protection relay		
<u>Protection Product</u>	Overcurrent – Directional	2
<u>Case I/O and Fascia</u>	E4 case, 1 CT, 3VT, 3 Binary Inputs / 5 Binary Outputs, 10 LEDs	4
	E4 case, 4 CT, 3VT, 3 Binary Inputs / 5 Binary Outputs, 10 LEDs	5
	E4 case, 4 CT, 3VT, 6 Binary Inputs / 8 Binary Outputs, 10 LEDs	6
<u>Measuring Input</u>	1/5 A, 63.5/110V, 50/60Hz <sup>1)</sup>	2
	1/5 A, 63.5/110V, 50/60Hz with SEF <sup>2)</sup>	4
<u>Auxiliary voltage</u>	80 to 250V DC, binary input threshold 19V DC	G
	80 to 250V DC, binary input threshold 88V DC	H
	24 to 60V DC, binary input threshold 19V DC	J
<u>Communication Interface</u>	Standard version – included in all models, USB front port, RS485 rear port	1
<u>Protocol</u>	IEC 60870-5-103 and Modbus RTU and DNP3 (user selectable setting)	2
<u>Relay Cover</u>	Standard Version – No Push Buttons	1
	Push Buttons – Down and Right Arrows	2
<u>Protection Function Packages</u>	Standard version – included in all models	C
	27/59 Under/overvoltage	
	37 Undercurrent	
	46BC <sup>3)</sup> Broken conductor/load unbalance	
	46NPS <sup>3)</sup> Negative phase sequence overcurrent	
	47 Negative phase sequence voltage	
	49 <sup>3)</sup> Thermal overload	
	50BF <sup>3)</sup> Circuit breaker fail	
	51V <sup>3)</sup> Voltage dependent overcurrent	
	59N Neutral voltage displacement	
	60CTS <sup>3)</sup> CT supervision	
	60VTS <sup>3)</sup> VT supervision	
	64H High Impedance REF	
	67/50 Directional instantaneous phase fault overcurrent	
	67/50G 67/50N Directional instantaneous earth fault	
	50SEF <sup>2)</sup> Directional instantaneous sensitive earth fault	
	67/51 Directional time delayed phase fault overcurrent	
	67/51G 67/51N Directional time delayed earth fault	
	67/51SEF <sup>2)</sup> Directional time delayed sensitive earth fault	
	81HBL <sup>2)</sup> 2 <sup>nd</sup> Harmonic Block/Inrush Restraint	
	74T/CC Trip & close circuit supervision	
	51c <sup>3)</sup> Cold load pickup	
	Programmable logic	
	Standard version – plus	D
	79 Autoreclose	
<u>Additional Functionality</u>	No Additional Functionality	A

<sup>1)</sup> 4CT is configured as 3PF + EF.

<sup>2)</sup> 4CT is configured as 3PF + SEF/REF.

<sup>3)</sup> Functions only available in 4CT relay

<sup>4)</sup> Not available in SEF model

## **Related Documents**

Technical Manual

## **Qualifications**

Siemens Protection Devices Limited operates a quality system accredited to ISO9001.  
CE Compliant to relevant EU Directives.

Siemens Protection Devices Limited  
PO Box 8  
North Farm Road  
Hebburn  
Tyne & Wear  
NE31 1TZ  
United Kingdom  
Tel: ++44 (0)191 401 7901  
Fax: ++44 (0)191 401 5575  
Web: [www.reyrolle-protection.com](http://www.reyrolle-protection.com)

PTD 24hr Customer Support  
Tel: +49 180 524 7000  
Fax: +49 180 524 2471  
E-mail: [support.energy@siemens.com](mailto:support.energy@siemens.com)

Data is subject to change without notification.

**09 April 2009**