

IF IN DOUBT ASK
DO NOT SCALE

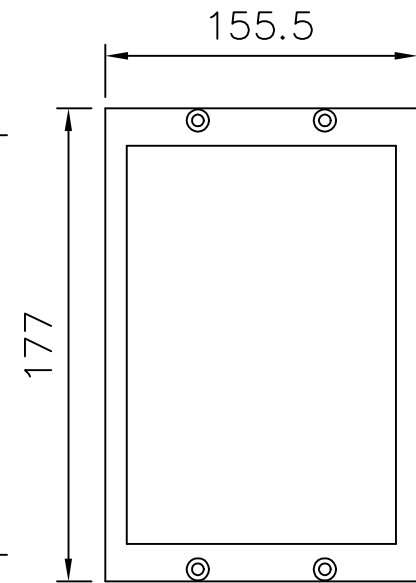
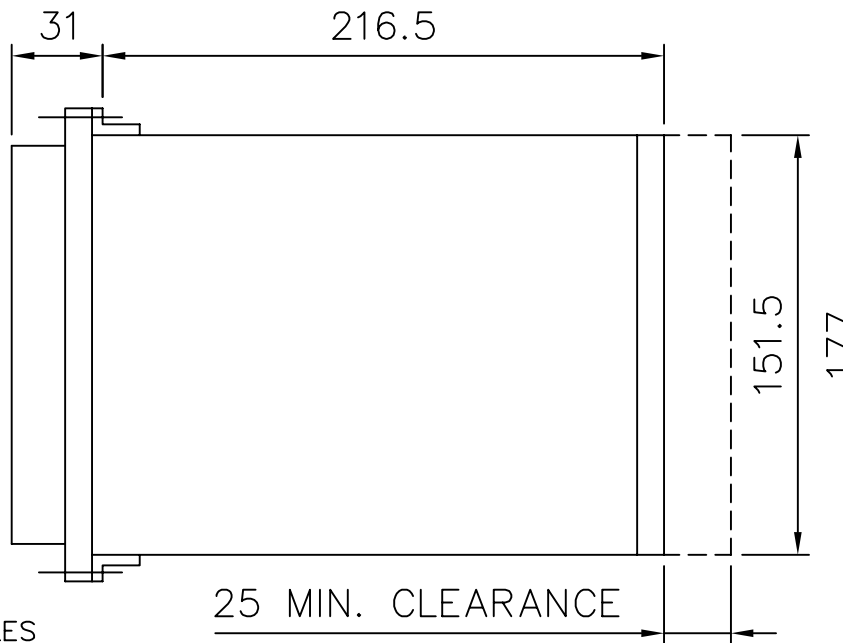
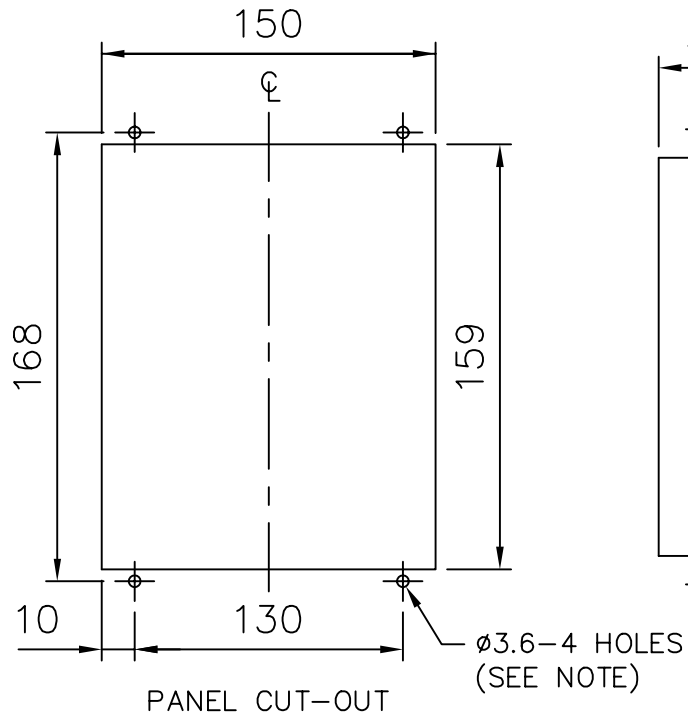

DRAWING OFFICE ONLY NOTE

ANY CHANGE TO THIS DRG MUST BE REFLECTED ON DRG 2995X10017 & CATALOGUE

NOT SUBJECT TO UPDATE
ONCE COPIED / PRINTED
OR DOWNLOADED

NOTE:

THE Ø3.6 HOLES ARE FOR M4 THREAD FORMING (TRILOBULAR) SCREWS. THESE ARE SUPPLIED AS STANDARD AND ARE SUITABLE FOR USE IN FERROUS/ALUMINIUM PANELS 1.6mm THICK AND ABOVE. FOR OTHER PANELS, HOLES TO BE M4 CLEARANCE (TYPICALLY Ø4.5) AND RELAYS MOUNTED USING M4 MACHINE SCREWS, NUTS AND LOCKWASHERS (SUPPLIED IN PANEL FIXING KIT).

Copyright © 1999 Reyrolle Ltd.

2	30/7/01	MN995/2125
1	12/07/99	CHANGE
ISSUE	DATE	NOTED

MATERIAL:

Dimensions in millimetres : Surface texture in micrometres. Machine where marked ✓ For explanation of dimensions, tolerances, notes etc. see B.S.308. Limit on untoleranced unmachined dimensions ± _____ Limits on untoleranced machined dimensions to B.S.4500; i.e. up to 6±0.1; over 30 to 120±0.3; over 315±0.8; over 6 to 30±0.2; over 120 to 315±0.5; General unmachined angular tolerance ± _____	Finish:	Title: OVERALL DIMENSIONS AND PANEL DRILLING FOR EPSILON E6 CASE.	First used on: _____ Similar Articles: _____ Supersedes: _____
	Treatment:	Reyrolle Protection Hebburn.	Original Scale: NTS
DRAWN: T.CARR CHECKED: _____ APPROVED: R.D.WATSON	DATE: 11/07/02 I.E. _____ OPS. _____ PCP. _____	Purch. Spec. _____ TQ. _____	EAC _____ CE. _____ STD. _____ A4h _____